

472683 Rev00

Please read these instructions thoroughly before installation
Veillez lire attentivement ces instructions avant l'installation
Por favor, lea estas instrucciones con atención antes de la instalación

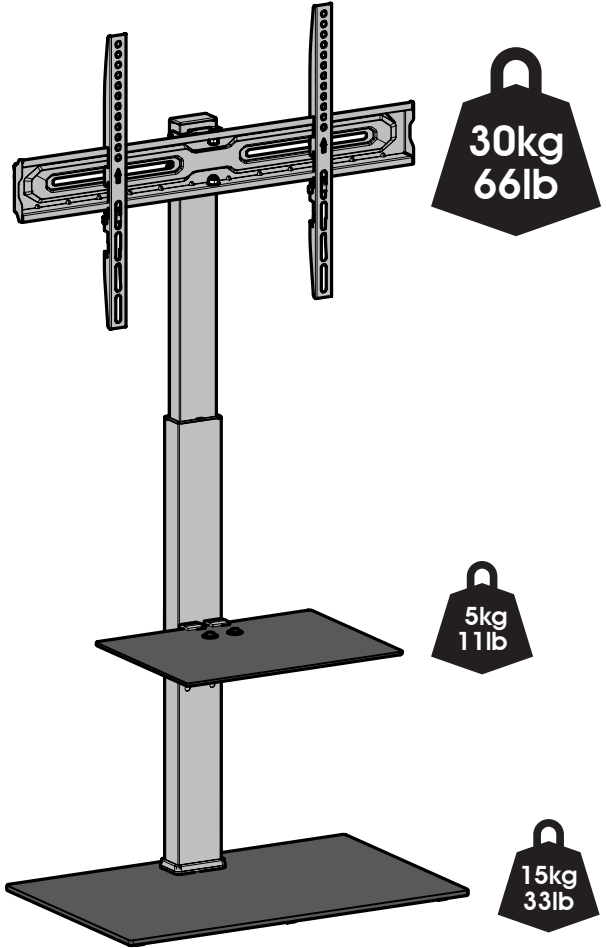

You will need
Vous aurez besoin de
Necesitará



Ø8mm (5/16") Masonry /
Maçonnerie / Masonería

Customer Helpline
Ligne d'assistance clientèle
Teléfono de atención al cliente

1-800 667 0808
(USA)

+44 (0) 333 320 0463
(UK)

Online Support
Assistance en ligne
Servicio técnico en línea
www.avfgroup.com/support

Boxed Parts
Pièces empaquetées
Piezas en la Caja

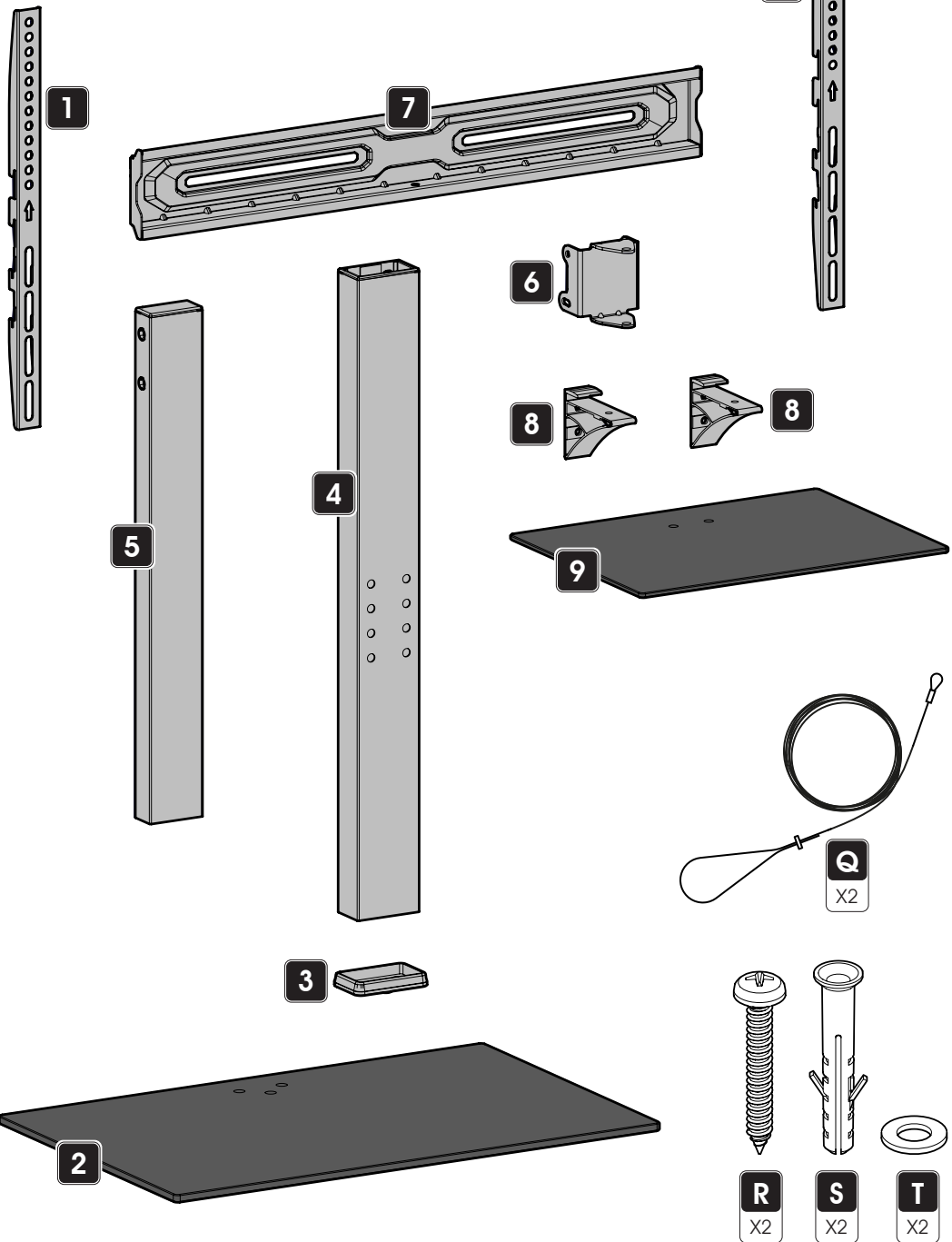

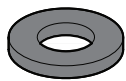

A
X5

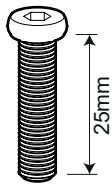

D
X3
M8

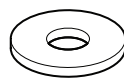

F
X2

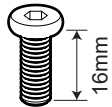

E
X8
M6

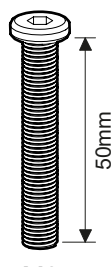

J
X4
M8

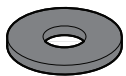

B
X2



C
X3

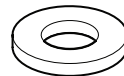

G
X8



H
X2

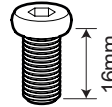

I
X4
M8



N
X6

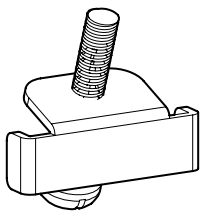

K
X2

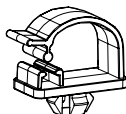

O
X3

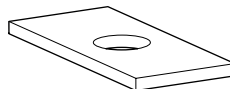

P
X2



L1
X1



L2
X1

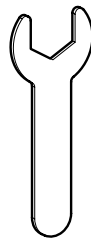

L3
X1

TV Screws, Reducers and Spacers
Vis TV, réducteurs et séparateurs
Tornillos, Reductores y Espaciadores para TV



TV8 X4



TV9 X4



TV10 X4

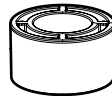

TV11 X4

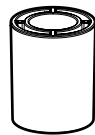

TV12 X4



TV1 X4
M4

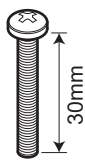

TV2 X4
M4

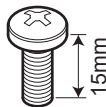

TV3 X4
M6

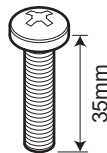

TV4 X4
M6

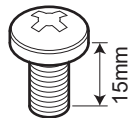

TV5 X4
M8

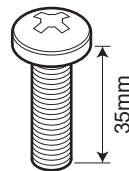

TV6 X4
M8

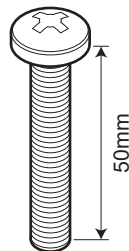

TV7 X4
M8

Measure the TV fixing holes Width and Height
Mesurer la profondeur et la taille des trous de fixation
Mida los orificios de su TV, lo ancho y lo alto

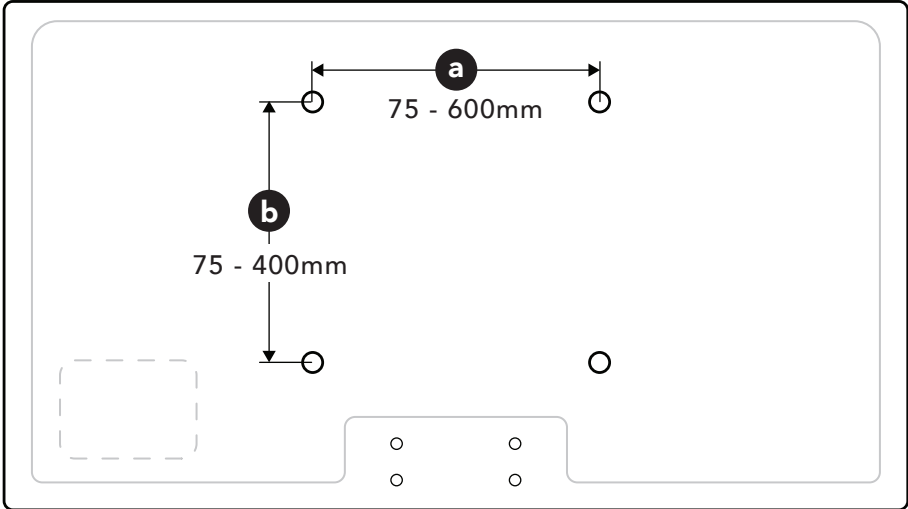

If width **a** is greater than 600mm or height **b** greater than 400mm STOP installation now and contact the customer helpline.



*Si la largeur **a** est plus large que 600mm et la hauteur **b** plus grande que 400mm, ARRÊTEZ l'installation immédiatement et contactez l'assistance client.*

Si la anchura **a** es mayor que 600mm o la altura de **b** es mayor que 400mm DETENGA la instalación inmediatamente y póngase en contacto con la línea de ayuda al cliente.

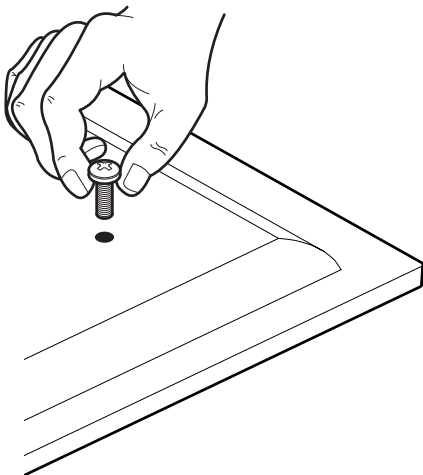

Determine which diameter TV Screws fit your TV and put them to one side.

M4, M6 or M8

We will select the correct length later.

Déterminez le diamètre des vis TV adapté à votre téléviseur et mettez-les de côté.

M4, M6 or M8

Nous sélectionnerons la longueur correcte plus tard.

Determine qué diámetro de los tornillos de TV son aptos para su TV y colóquelos en un lado.

M4, M6 or M8

Seleccionaremos la longitud correcta más adelante.

1

Put a piece of material underneath the glass to prevent damage.
 Mettre un morceau de tissu sous le verre pour éviter de l'endommager.
 Coloque un pedazo del material debajo de los paneles para evitar cualquier daño.

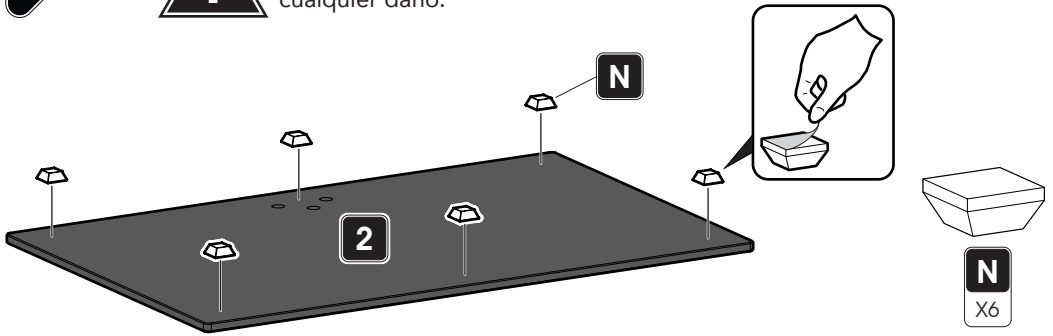
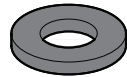
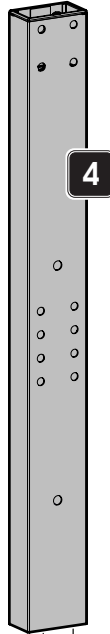
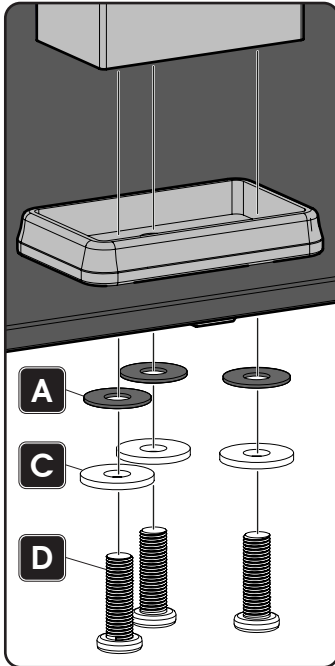
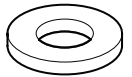
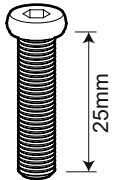
**2****A**
X3**C**
X3**D**

X3

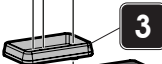
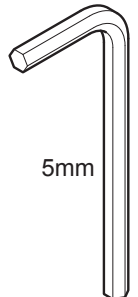
**3**

5mm

L1

X1

3

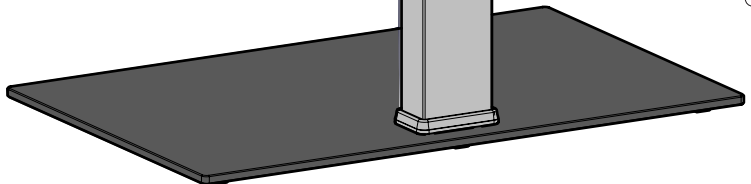
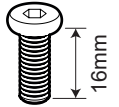
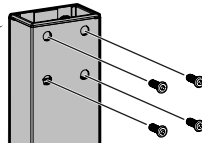
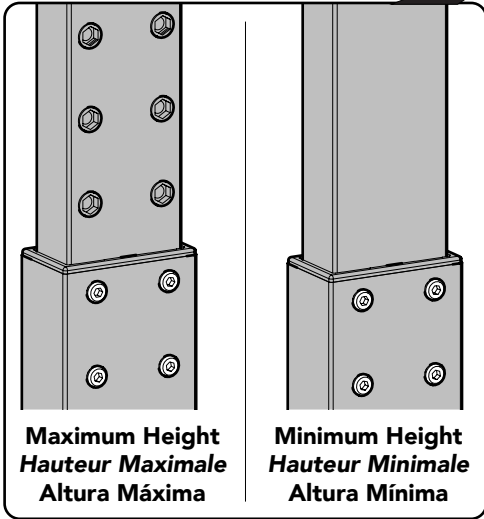
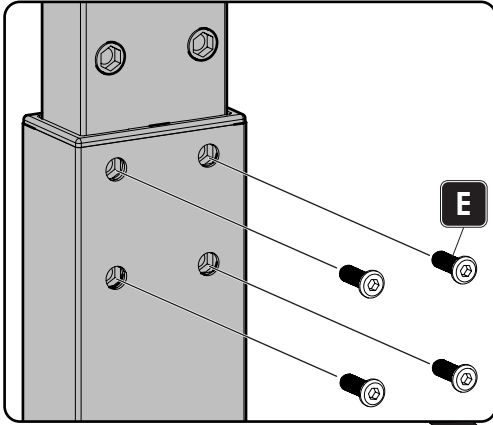

4

i

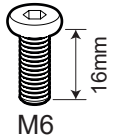
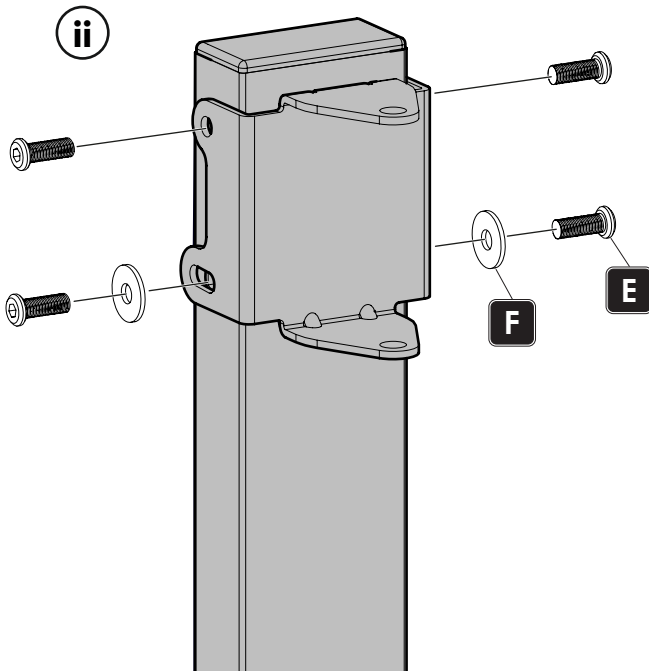
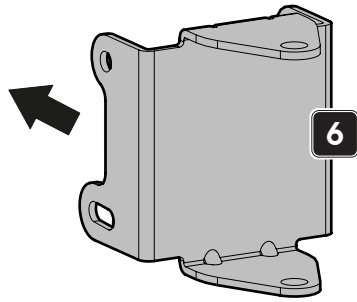
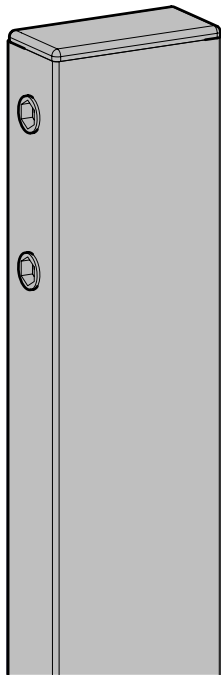

M6

E
X4

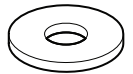

F
X2

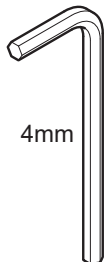

4mm

L2
X1

5

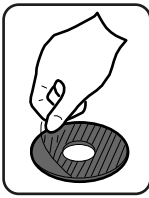

B

i

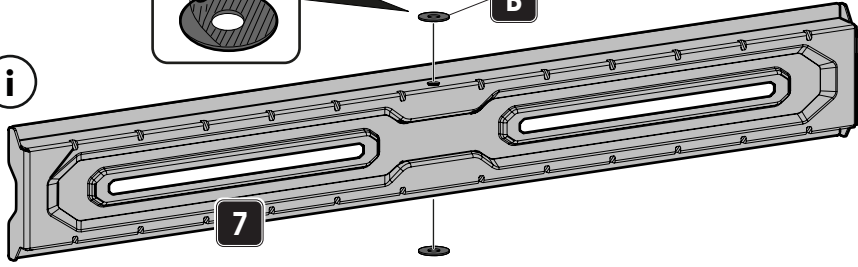

7

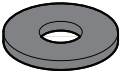

B
X2

ii

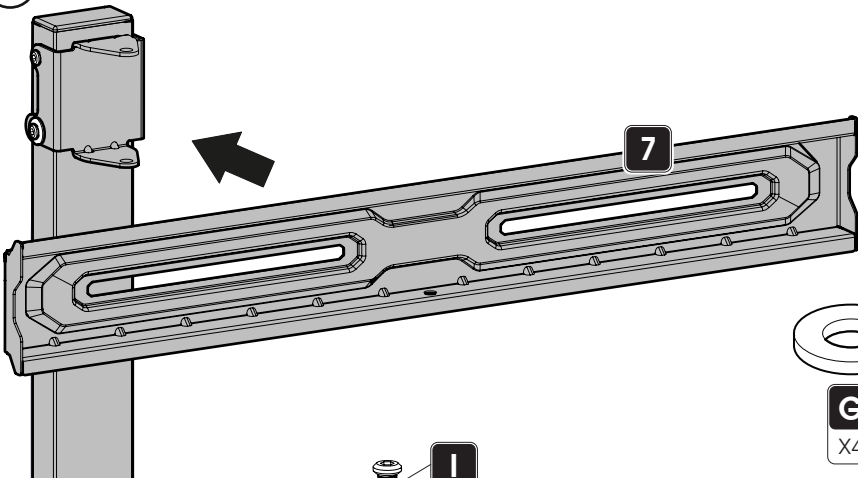

7

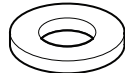

G
X4



H
X2

iii

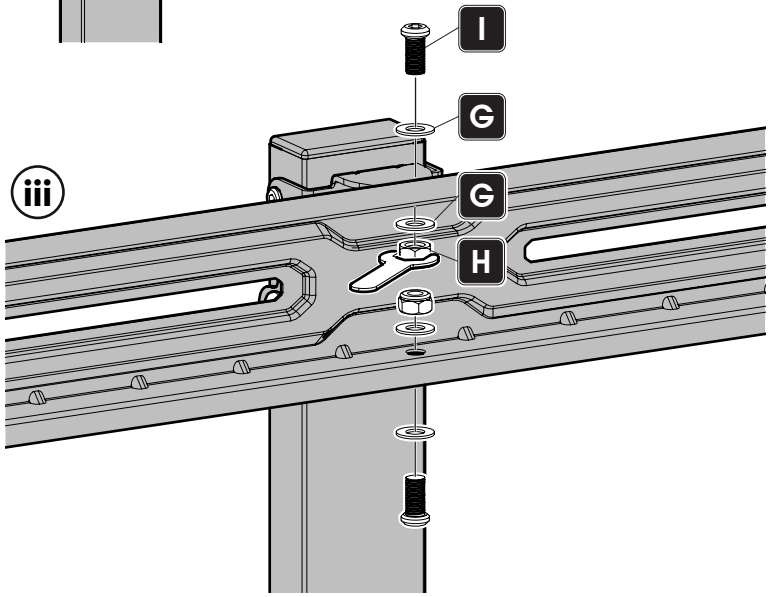

I

G

G

H

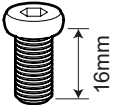

M8
I
X2

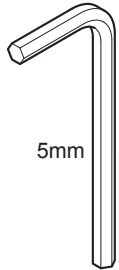

5mm

L1
X1

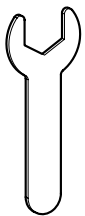

L3
X1

6



After completing this step, you will have lots of TV screws left over. Keep them in a safe place in case you require them in future.

Après avoir effectué cette étape, il vous restera de nombreuses vis de téléviseur. Gardez-les dans un endroit sûr au cas où vous en auriez besoin dans le futur.

Después de completar este paso, quedarán muchos tornillos de TV.

Guárdelos en un lugar seguro por si los necesita en el futuro.

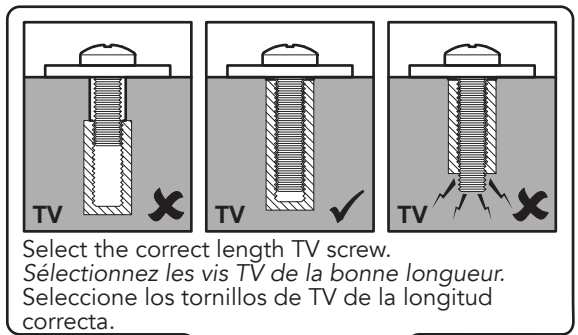

Select the correct length TV screw.
Sélectionnez les vis TV de la bonne longueur.
Seleccione los tornillos de TV de la longitud correcta.

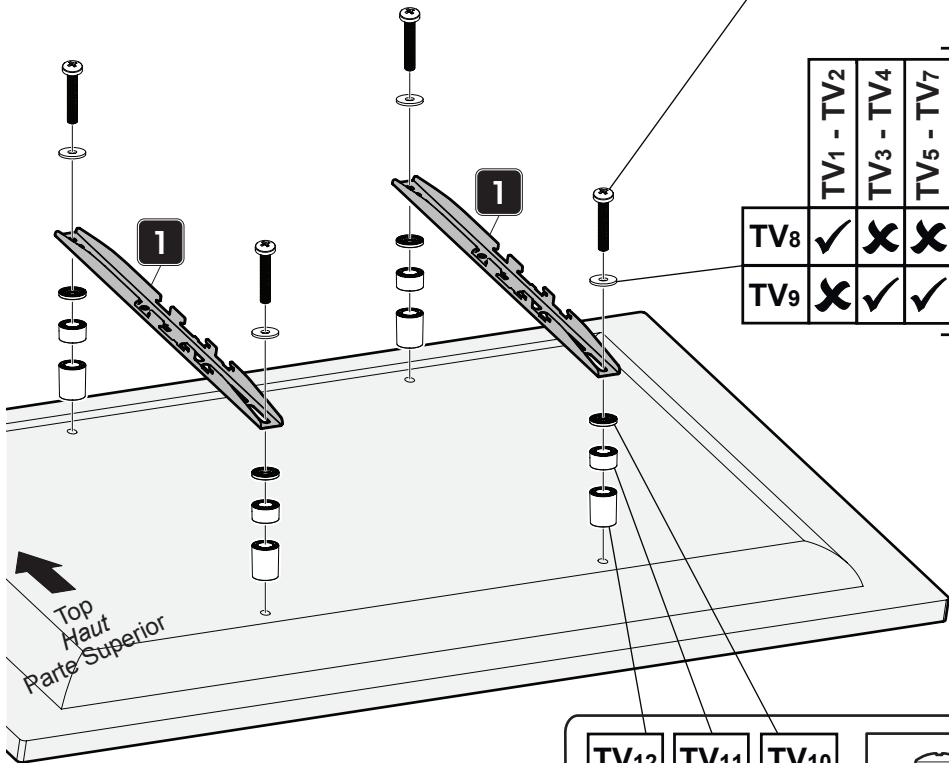
TV₁ - TV₇

	TV ₁ - TV ₂	TV ₃ - TV ₄	TV ₅ - TV ₇
TV ₈	✓	✗	✗
TV ₉	✗	✓	✓

Do you need TV₈ or TV₉?
Avez-vous besoin de TV₈ ou TV₉?
Necesitas TV₈ o TV₉?

TV₁₂ TV₁₁ TV₁₀

If required
Si nécessaire
Si se requiere

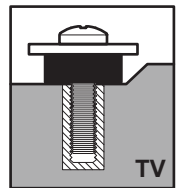

You may need to use Spacers TV₁₀, TV₁₁ or TV₁₂ if the screws are too long or the back of your TV is not flat.

Il se peut que vous deviez utiliser des entretoises TV₁₀, TV₁₁ ou TV₁₂ si les vis sont trop longues ou si le dos de votre téléviseur n'est pas plat.

Puede que tenga que usar separadores TV₁₀, TV₁₁ o TV₁₂ si los tornillos son demasiado largos o si la parte trasera de su TV no es plana.

7

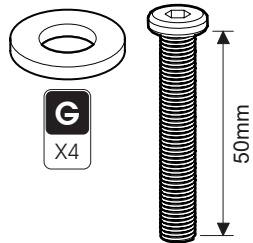
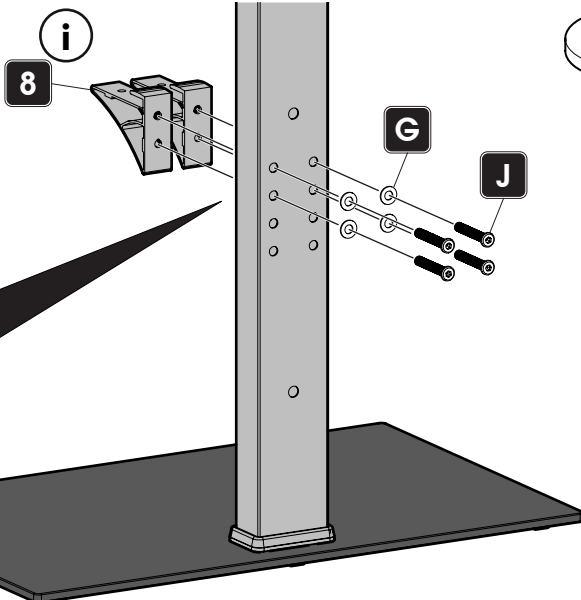

M8

J X4

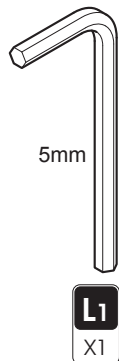

5mm

L1 X1

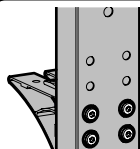

Low
Basse
Bajo

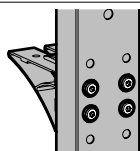

Medium
Moyen
Medio

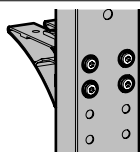

High
Haute
Alto

ii

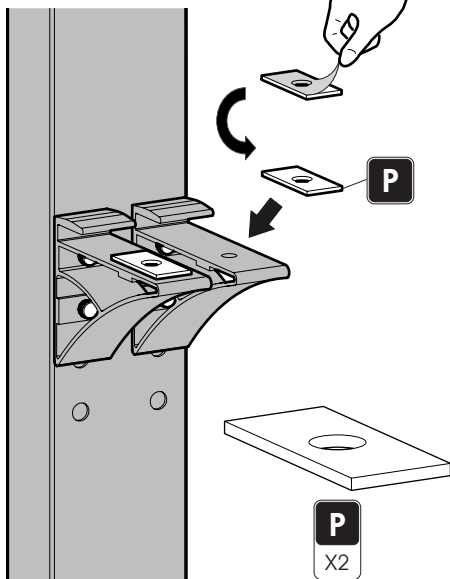

P X2

iii

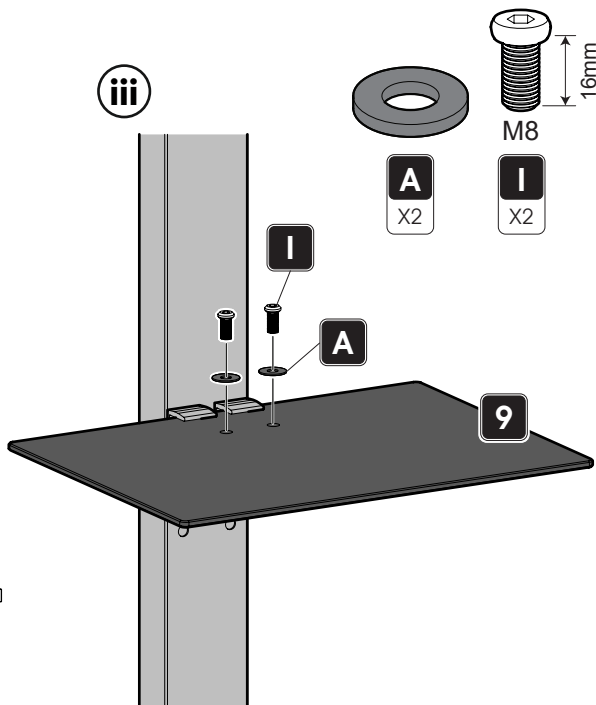

M8

A X2

I X2

16mm

9

8

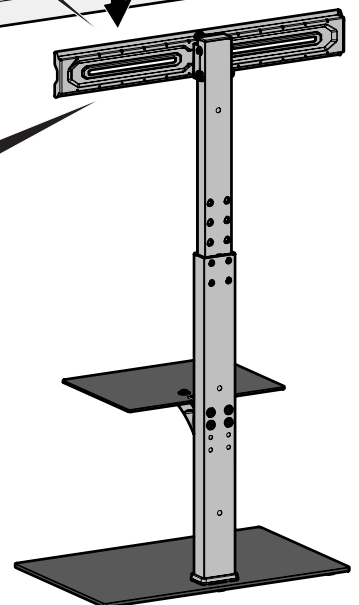
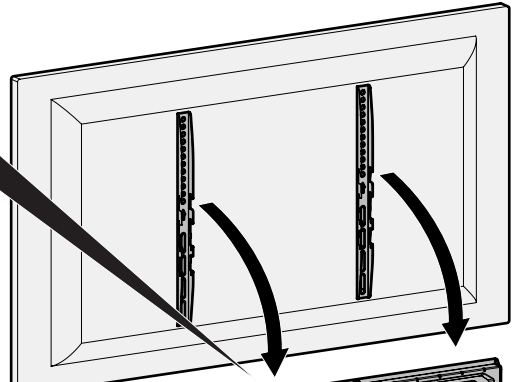
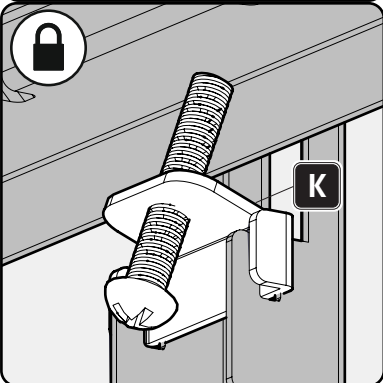
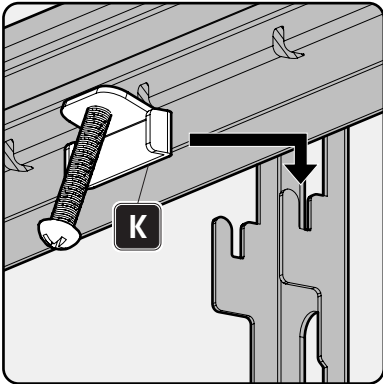
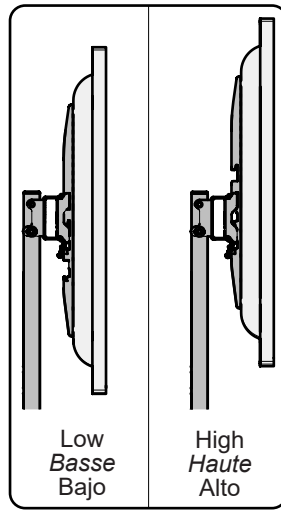
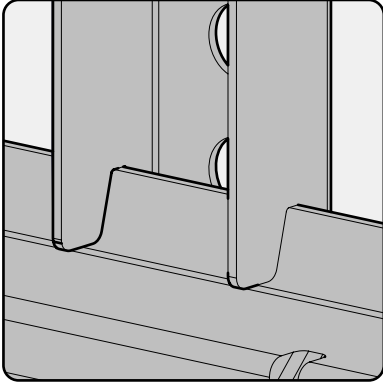

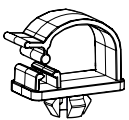
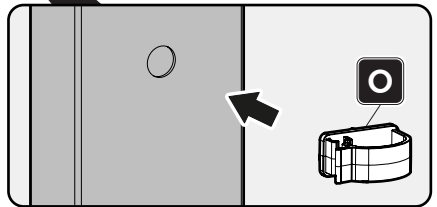
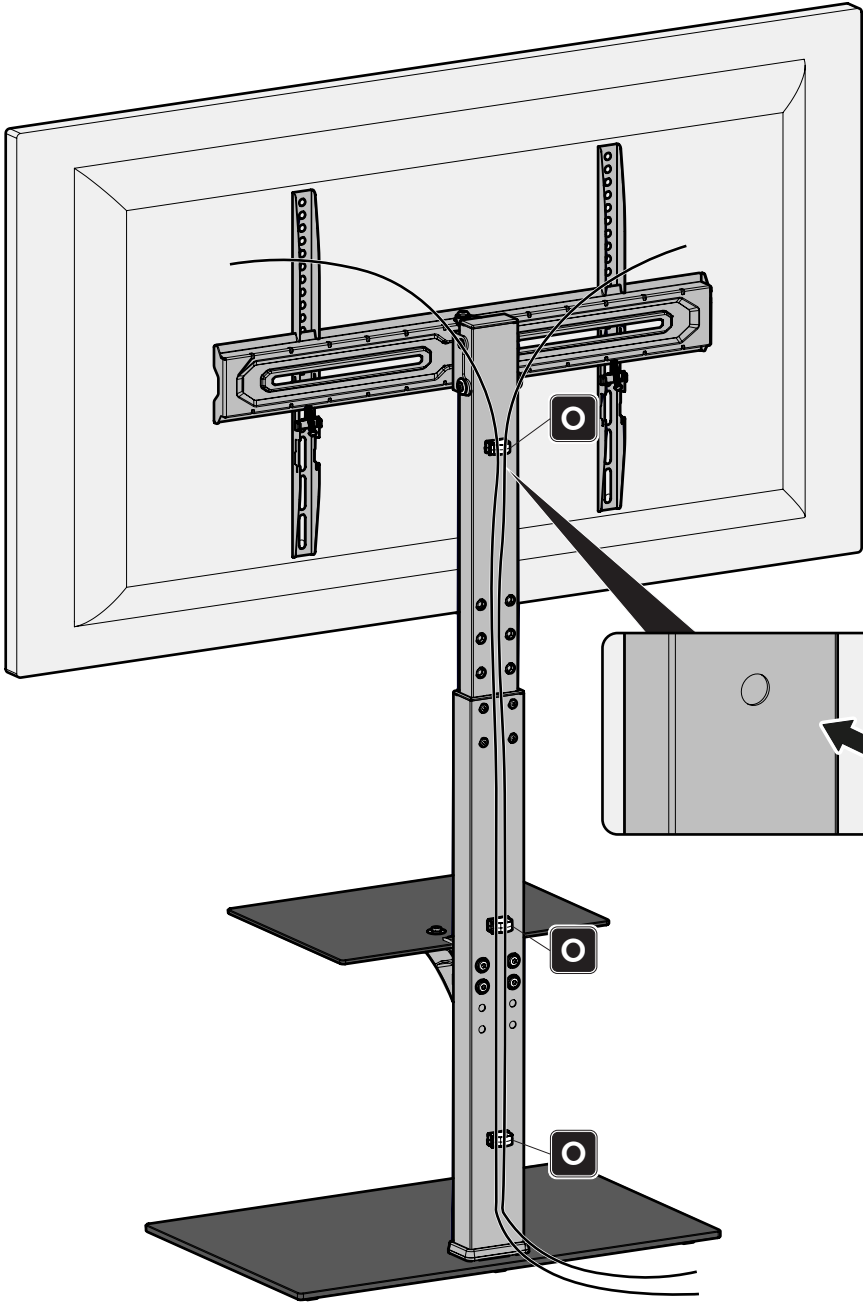

X3

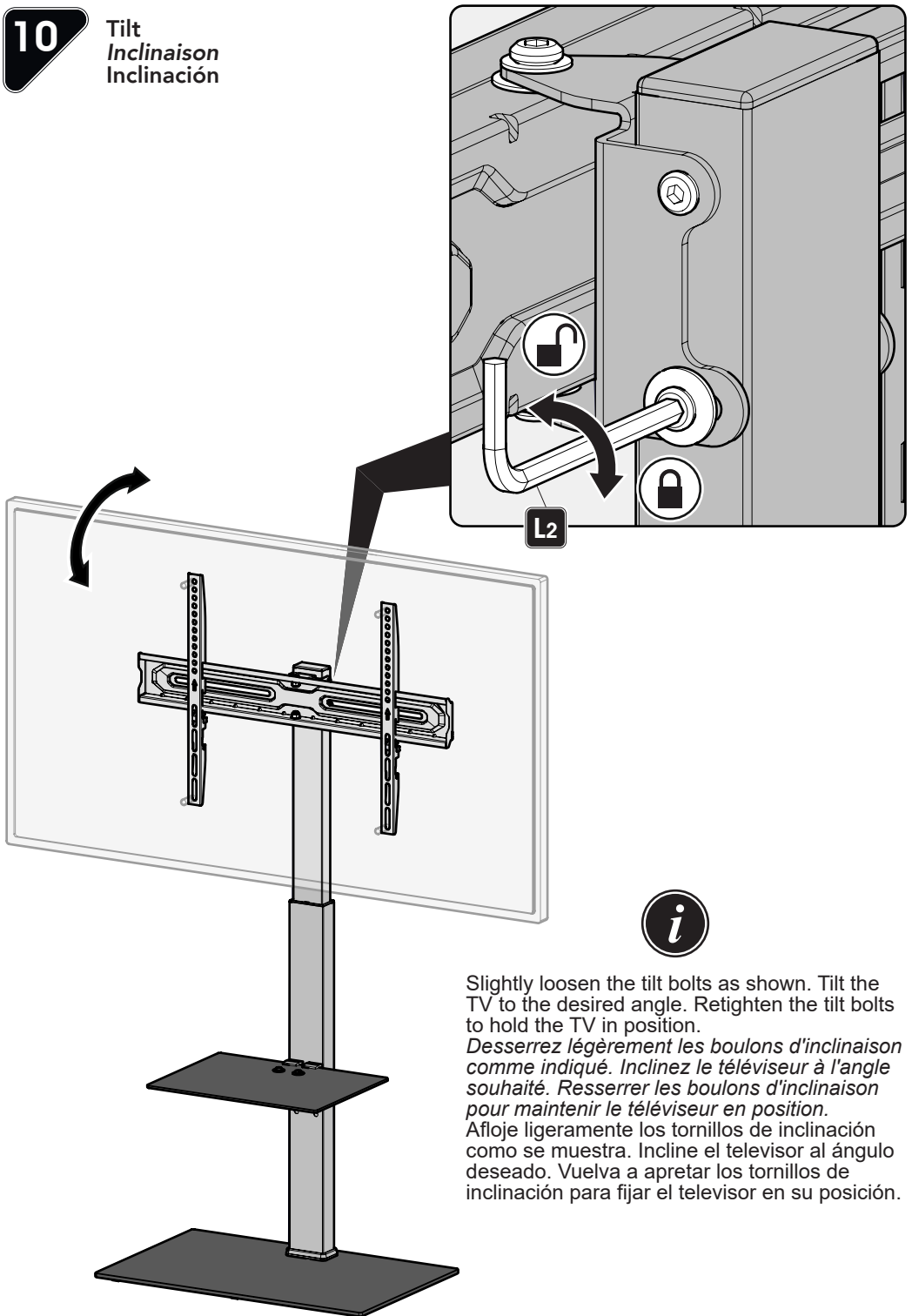
10**Tilt
Inclinaison
Inclinación**

Slightly loosen the tilt bolts as shown. Tilt the TV to the desired angle. Retighten the tilt bolts to hold the TV in position.

Desserrez légèrement les boulons d'inclinaison comme indiqué. Inclinez le téléviseur à l'angle souhaité. Resserrer les boulons d'inclinaison pour maintenir le téléviseur en position.

Afloje ligeramente los tornillos de inclinación como se muestra. Incline el televisor al ángulo deseado. Vuelva a apretar los tornillos de inclinación para fijar el televisor en su posición.

11

Swivel
Faire Tourner
Girar

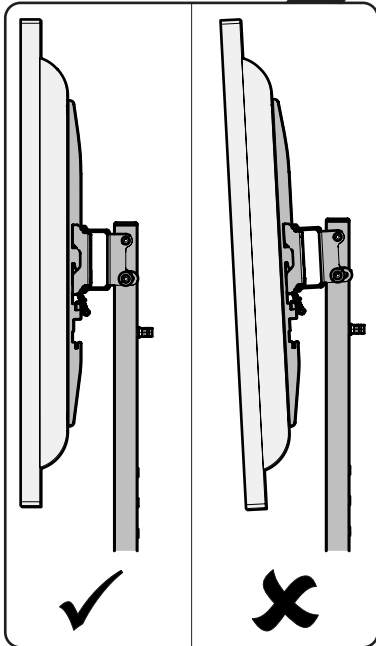
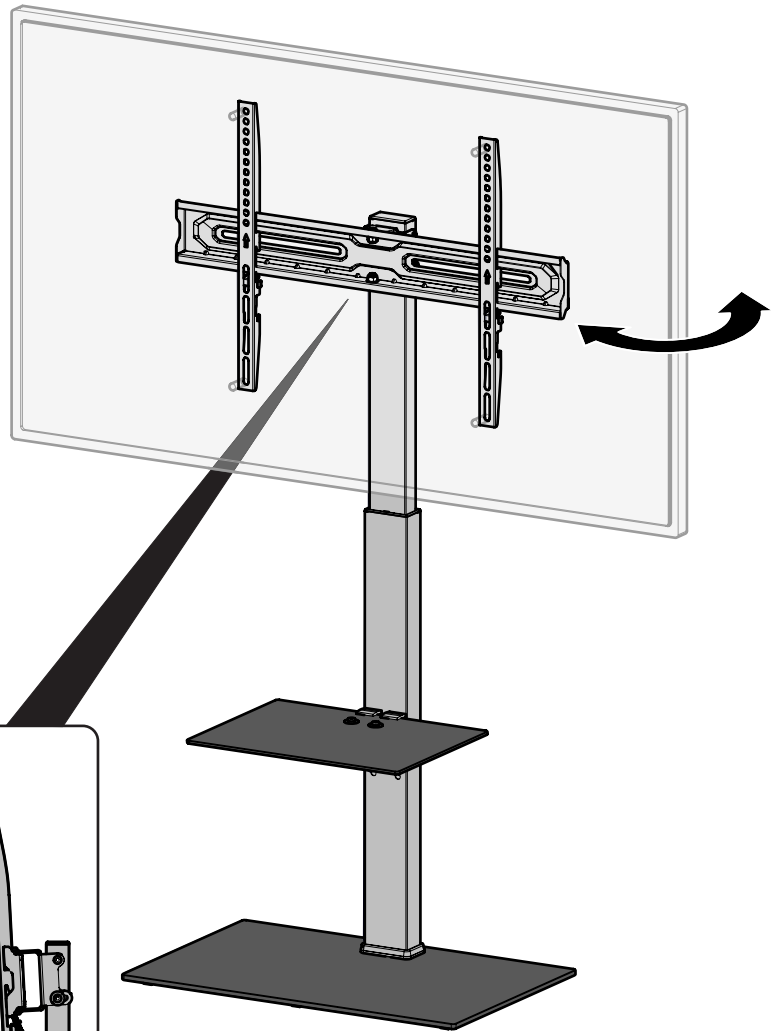

When making use of the swivel function, make sure the TV is vertical (i.e. not tilted) before rotating the TV.

Lorsque vous utilisez la fonction pivotante, assurez-vous que le téléviseur est vertical (c'est-à-dire non incliné) avant de le faire pivoter.

Al utilizar la función de giro, asegúrese de que el televisor esté en posición vertical (es decir, no inclinado) antes de girarlo.

12

Safety Cable
Câble de sécurité
Cable de seguridad

