

472092 Rev03

[EN] Please read these instructions thoroughly before installation
[FR] Veuillez lire attentivement ces instructions avant l'installation
[ES] Por favor, lea estas instrucciones con atención antes de la instalación

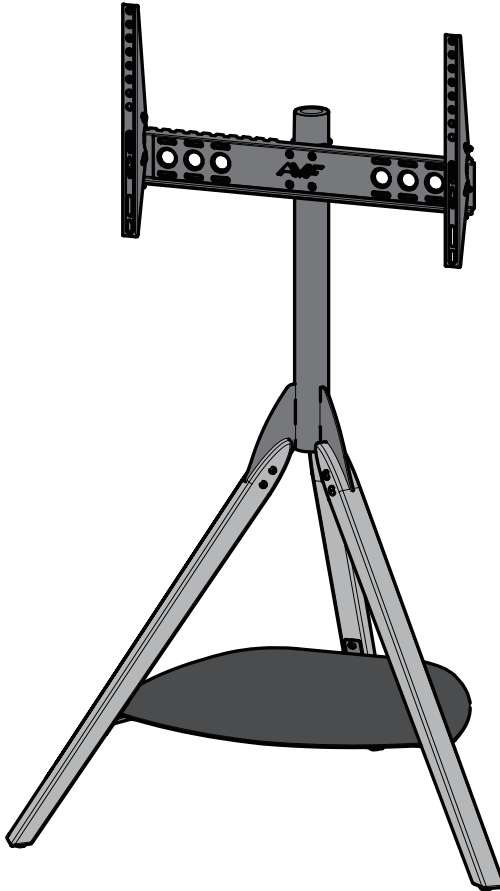

[EN] Customer Helpline
[FR] Ligne d'assistance clientèle
[ES] Teléfono de atención al cliente

1-800 667 0808
(USA)

+44 (0) 333 320 0463
(UK)

[EN] Online Support
[FR] Assistance en ligne
[ES] Servicio técnico en línea

www.avfgroup.com/support

[EN] IMPORTANT INFORMATION!

We advise that before starting the assembly of this product that you familiarise yourself with the instructions and the parts list in this leaflet.

[FR] INFORMATIONS IMPORTANTES!

Nous vous recommandons de vous familiariser avec ces instructions et la liste des pièces détachées contenues dans ce document avant de commencer l'assemblage de ce produit.

[ES] INFORMACIÓN IMPORTANTE!

Le recomendamos que antes de comenzar el ensamblaje de este producto se familiarize con las instrucciones y la lista de partes en esta hoja informativa.

[EN] Do not's

Do not overtighten any part of this assembly.

Do not place hot or cold objects on to or next to any surface unless the object is sufficiently insulated to prevent contact.

Do not strike any part of the stand with hard or pointed items.

Do not sit, stand or climb upon any part of this furniture.

Do not use washing powders or other substances containing abrasives when cleaning the wood or glass.

[FR] À ne pas faire

Ne serrez pas trop fort aucun des éléments de cet assemblage.

Ne placez pas d'objets chauds ou froids sur ou à côté d'une surface, sauf si l'objet est suffisamment isolés pour éviter tout contact.

Ne frappez aucune partie du support avec des objets durs ou pointus.

Ne pas vous asseoir, vous tenir debout ou grimper sur toute partie de ce meuble.

N'utilisez pas de poudres à laver ou d'autres substances contenant des abrasifs pour nettoyer le bois ou le verre.

[ES] No haga

No apriete demasiado ninguna de las piezas de este soporte.

No situar objetos calientes o fríos sobre o al lado de cualquier superficie a menos que el objeto esté suficientemente aislado para evitar el contacto.

No golpear ninguna parte del soporte con objetos duros o afilados.

No se siente ni se pare ni se suba sobre ninguna parte de este mobiliario.

No usar detergentes u otras sustancias que contengan elementos abrasivos al limpiar la madera o el cristal.

[EN] Do's

Do use a soft cloth with a suitable furniture polish when cleaning wooden panels.

Do use a damp cloth with diluted washing up liquid for cleaning the glass surfaces.

Check all nuts and bolts from time to time.

[FR] À faire

Utilisez un chiffon doux avec un produit adapté pour le nettoyage des meubles afin de nettoyer les panneaux en bois.

Utilisez un chiffon humide imprégné de liquide vaisselle dilué pour le nettoyage des surfaces en verre.

Vérifiez tous les écrous et les boulons de temps à autre.

[ES] Si haga

Use un trapo suave con limpiador o embellecedor de muebles cuando limpie paneles de madera.

Use un trapo suave con líquido diluido en agua para limpiar las superficies de vidrio.

Compruebe todos los tornillos y tuercas de vez en cuando.

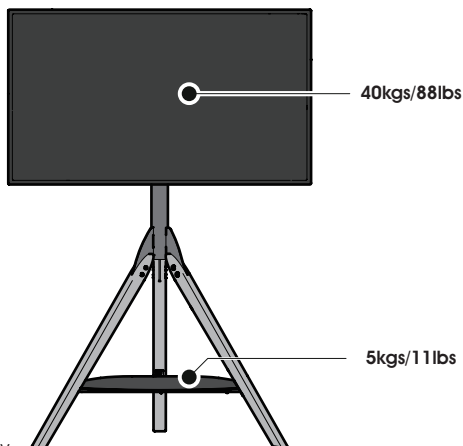
[EN] Maximum TV weight and shelf capacities**[FR] Poids maximal du téléviseur et capacité de charge de l'étagère****[ES] Máximo peso y capacidad del estante de TV**

[EN] WARNING: Wherever possible distribute weight evenly.

[FR] AVERTISSEMENT : Répartissez le poids de manière uniforme lorsque cela est possible.

[ES] ADVERTENCIA: En la medida de lo posible distribuya el peso uniformemente.

[EN] Boxed Parts
[FR] Pièces empaquetées
[ES] Piezas en la Caja

[EN] Tools Recommended
[FR] Outils recommandés
[ES] Herramientas recomendadas

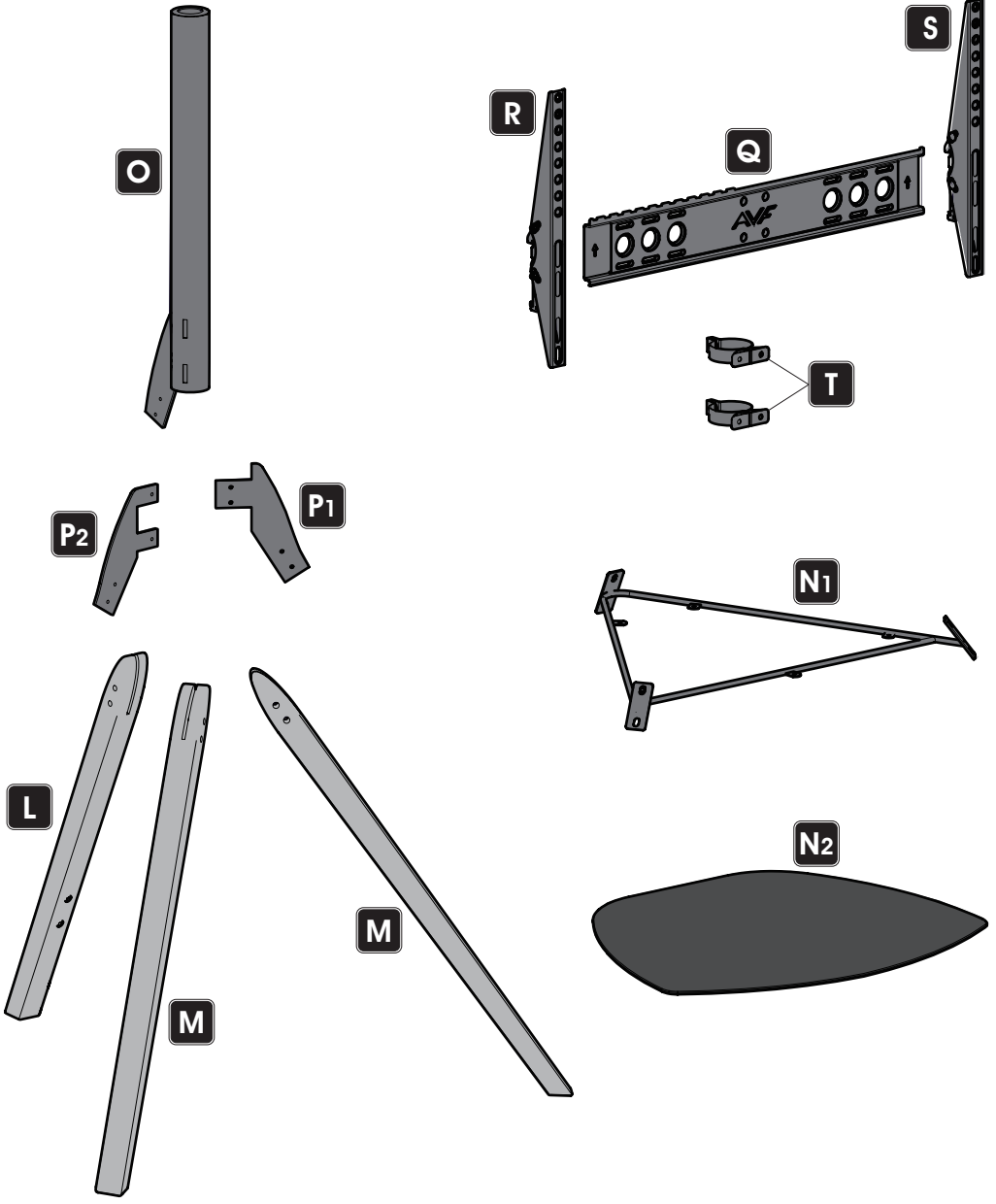
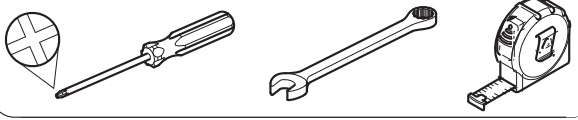

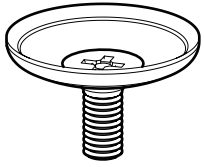

A
X5

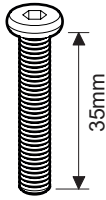

M6
B
X6

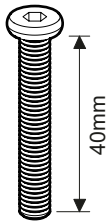

M6
C
X4

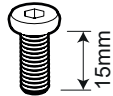

M6
D
X6



E
X6

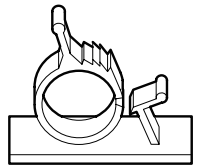

F
X3

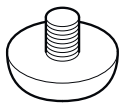

G
X3



4mm
H1
X1



5mm
H2
X1

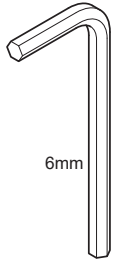

6mm
H3
X1

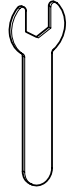

H4
X1

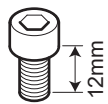

12mm
M6
I
X4



M6
J
X4

[EN] TV Screws, Reducers and Spacers
[FR] Vis TV, réducteurs et séparateurs
[ES] Tornillos, Reductores y Espaciadores para TV



RE1 x4



RE2 x4



SP1 x4



SP2 x4



M4
TV1 x4

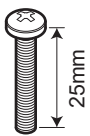

M4
25mm
TV2 x4

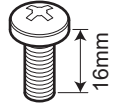

M6
16mm
TV3 x4

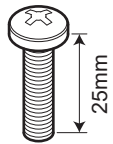

M6
25mm
TV4 x4

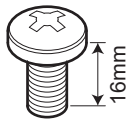

M8
16mm
TV5 x4

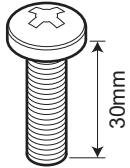

M8
30mm
TV6 x4

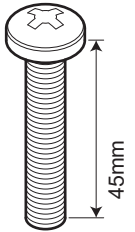

M8
45mm
TV7 x4

[EN] Measure the TV fixing holes Width and Height
[FR] Mesurer la profondeur et la taille des trous de fixation
[ES] Mida los orificios de su TV, lo ancho y lo alto

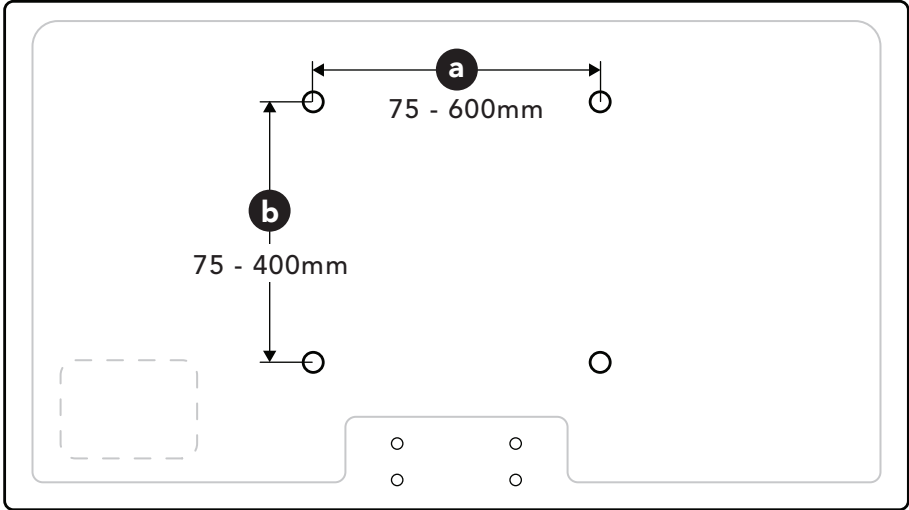

[EN] If width **a** is greater than 600mm or height **b** greater than 400mm STOP installation now and contact the customer helpline.

[FR] Si la largeur **a** est plus large que 600mm et la hauteur **b** plus grande que 400mm, ARRÊTEZ l'installation immédiatement et contactez l'assistance client.

[ES] Si la anchura **a** es mayor que 600mm o la altura de **b** es mayor que 400mm DETENGA la instalación inmediatamente y póngase en contacto con la línea de ayuda al cliente.

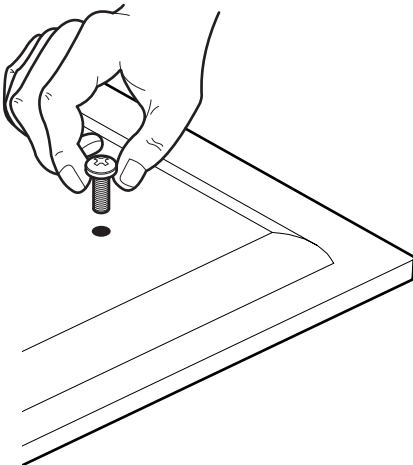

[EN] Determine which diameter TV Screws fit your TV and put them to one side.

M4, M6 or M8

We will select the correct length later.

[FR] Déterminez le diamètre des vis TV adapté à votre téléviseur et mettez-les de côté.

M4, M6 or M8

Nous sélectionnerons la longueur correcte plus tard.

[ES] Determine qué diámetro de los tornillos de TV son aptos para su TV y colóquelos en un lado.

M4, M6 or M8

Seleccionaremos la longitud correcta más adelante.

1

i

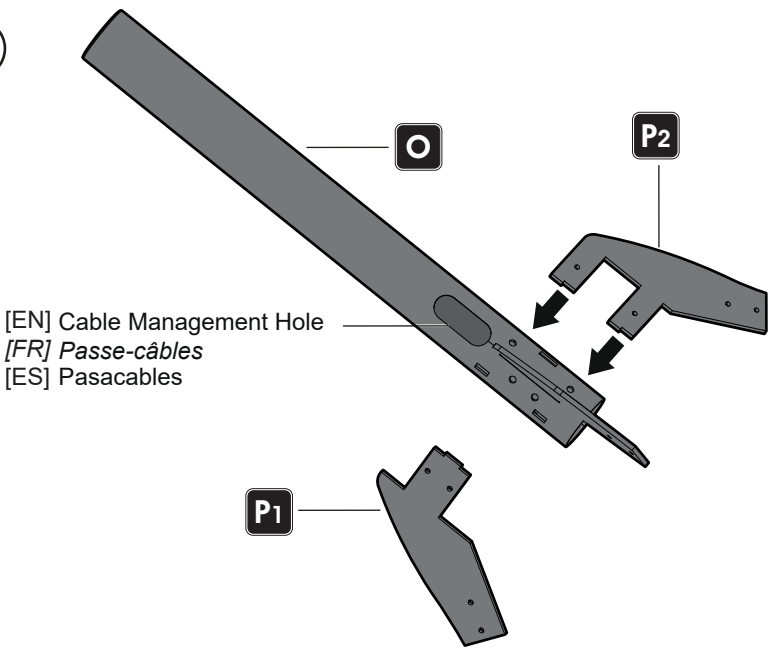

ii

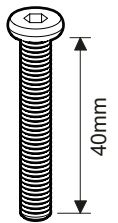
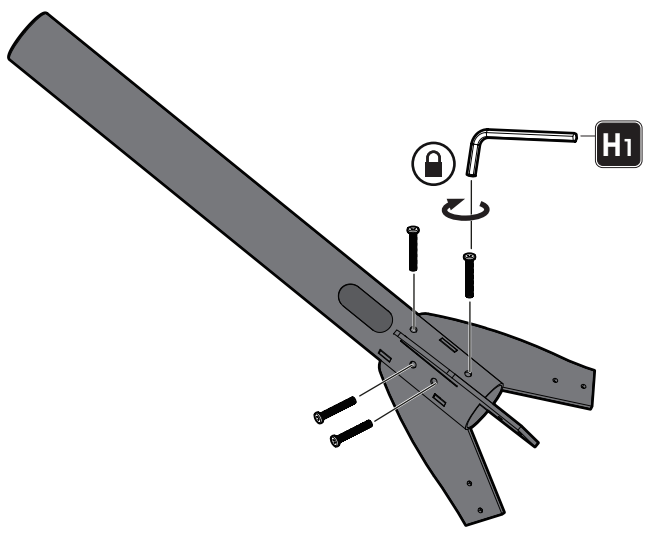

M6

C
X4

2

[EN] When the legs are fitted the column should lean backwards slightly.
This is for extra stability.

[FR] Une fois les pieds sont montés, la colonne s'incline légèrement vers l'arrière. Pour une stabilité renforcée.

[ES] Cuando se ajustan las patas, la columna debería inclinarse ligeramente hacia atrás. Esto es para una mayor estabilidad.

[EN] Install leg **L** on the side with the cable management hole.

[FR] Installer la pièce **L** du côté avec le passe-câbles.

[ES] Instalar la pieza **L** en el lado con el pasacables.



[EN] Fully tighten Screw **B** before tightening **E**.

[FR] Serrez complètement la Vis **B** avant de serrer **E**.

[ES] Apriete a fondo el tornillo **B** antes de apretar el **E**.

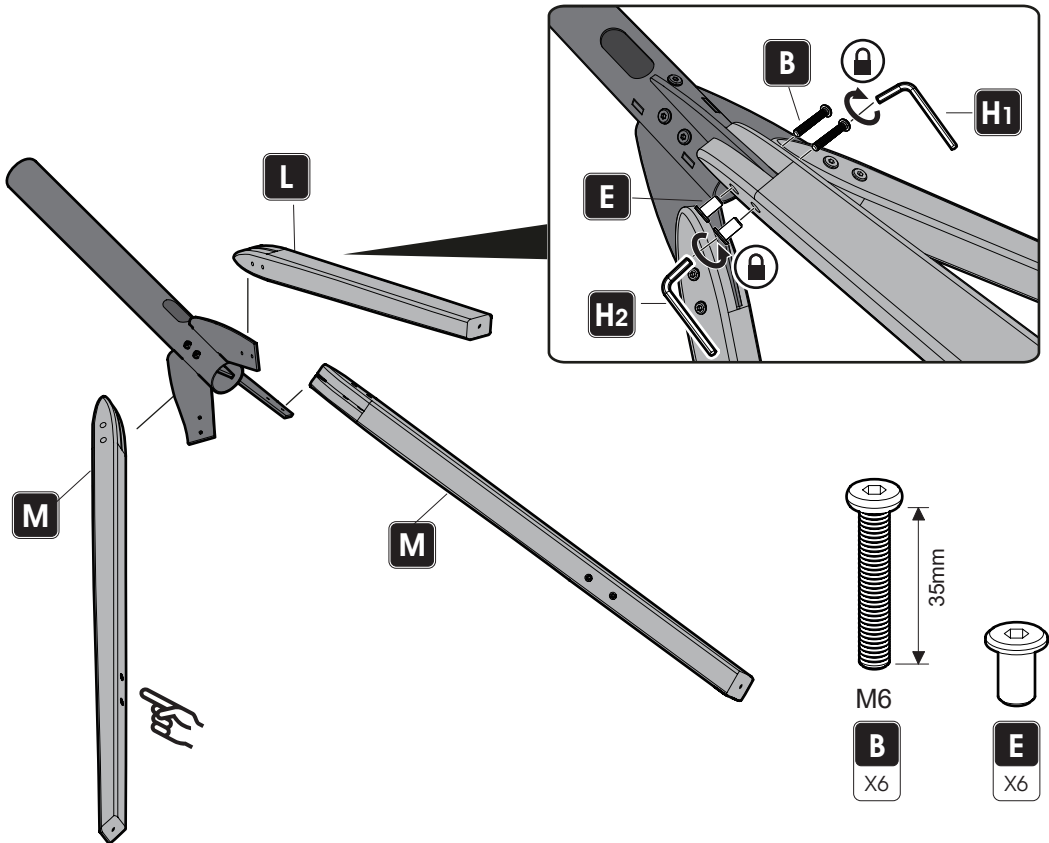

3

i

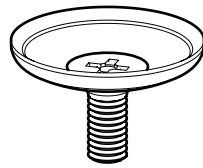

A
X5

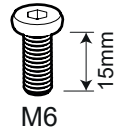

D
X6
M6
15mm

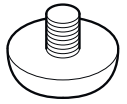

G
X3

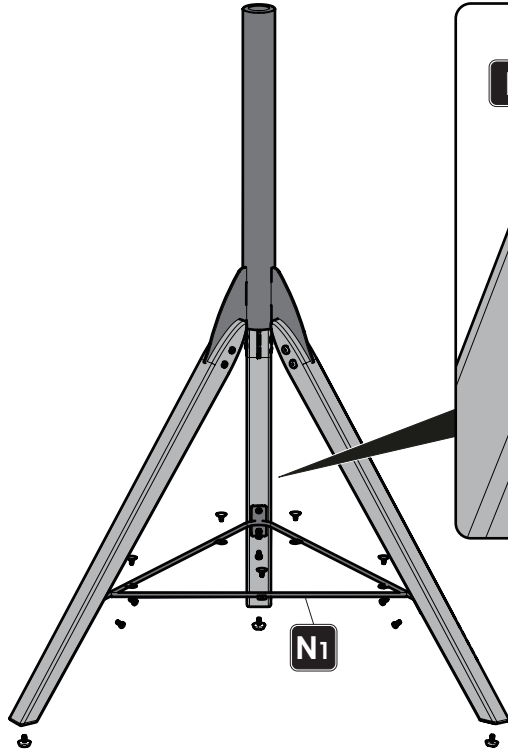

N1

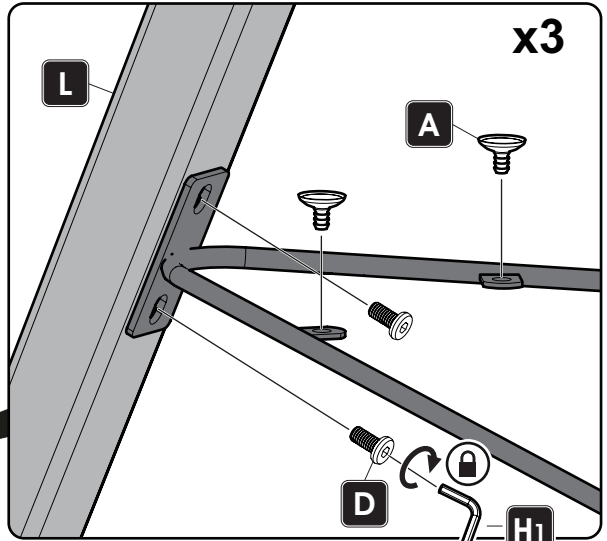

L

A

D

x3



H1

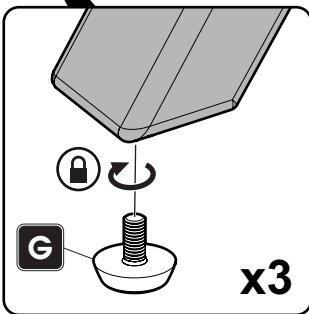

G

x3

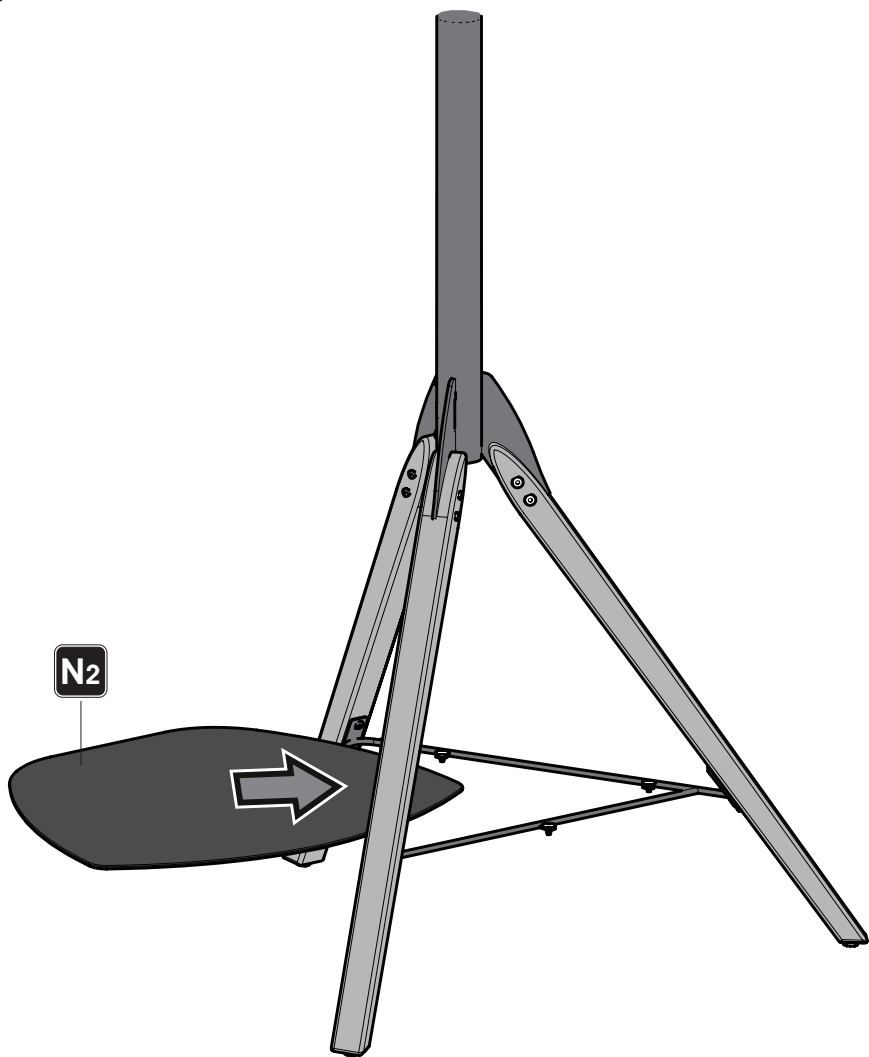

iv

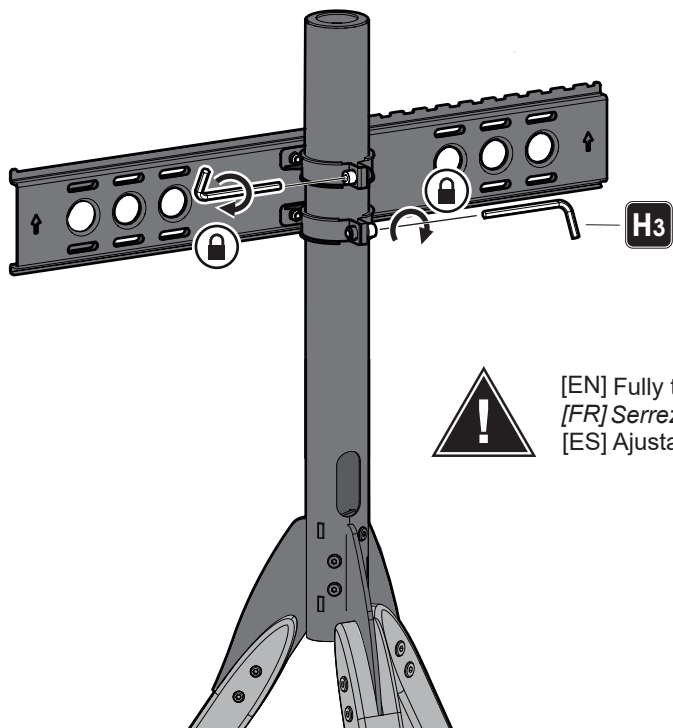

v

[EN] Check bracket is level before fully tightening.
[FR] Vérifiez si le support est au niveau, avant de serrer complètement.
[ES] Revise si el soporte está nivelado antes de ajustar completamente.

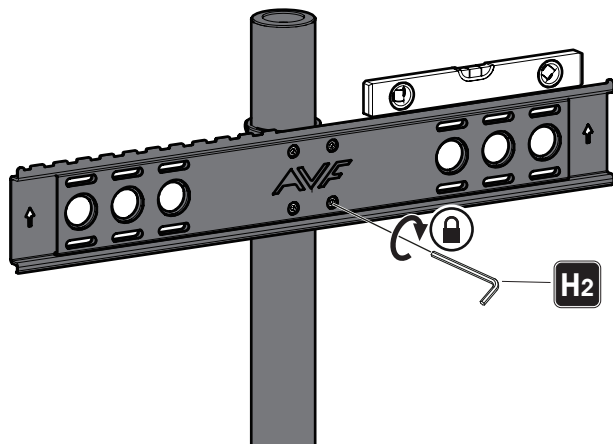

5



[EN] After completing this step, you will have lots of TV screws left over. Keep them in a safe place in case you require them in future.

[FR] Après avoir effectué cette étape, il vous restera de nombreuses vis de téléviseur. Gardez-les dans un endroit sûr au cas où vous en auriez besoin dans le futur.

[ES] Después de completar este paso, quedarán muchos tornillos de TV. Guárdelos en un lugar seguro por si los necesita en el futuro.

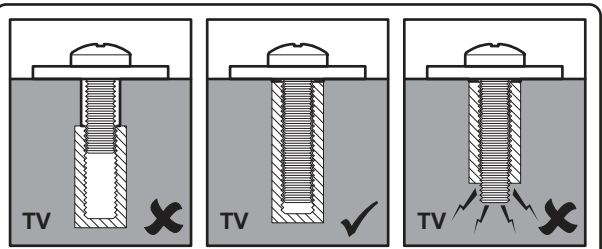

[EN] Select the correct length TV screw.

[FR] Sélectionnez la longueur correcte de la vis TV.

[ES] Seleccione el tornillo de TV de la longitud correcta.

TV1 - TV7

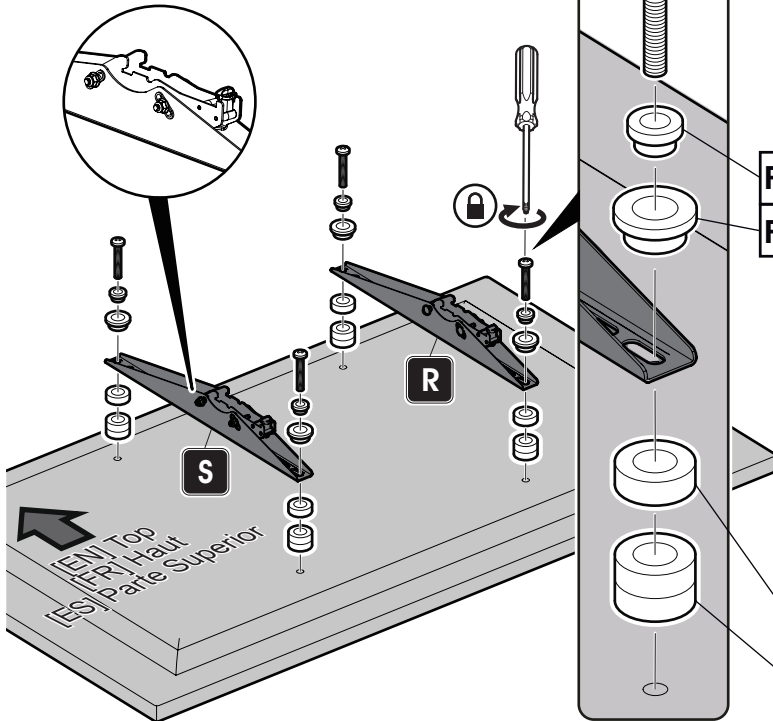

	TV1 - TV2	TV3 - TV4	TV5 - TV7
RE1	✓	✗	✗
RE2	✓	✓	✗

[EN] Do you need RE1 or RE2?
 [FR] Avez-vous besoin de RE1 ou RE2?
 [ES] Necesitas RE1 o RE2?

SP2
 SP1

[EN] If required
 [FR] Si nécessaire
 [ES] Si se requiere

[EN] You may need to use Spacers **SP1** or **SP2** if the screws are too long or the back of your TV is not flat.

[FR] Vous devrez peut-être utiliser l'entretoise **SP1** ou **SP2** si les vis sont trop longues ou si l'arrière de votre téléviseur n'est pas plat.

[ES] Es posible que deba usar Spacers **SP1** o **SP2** si los tornillos son demasiado largos o si la parte posterior de su televisor no está plana.

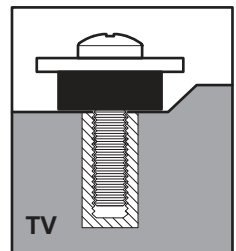

6

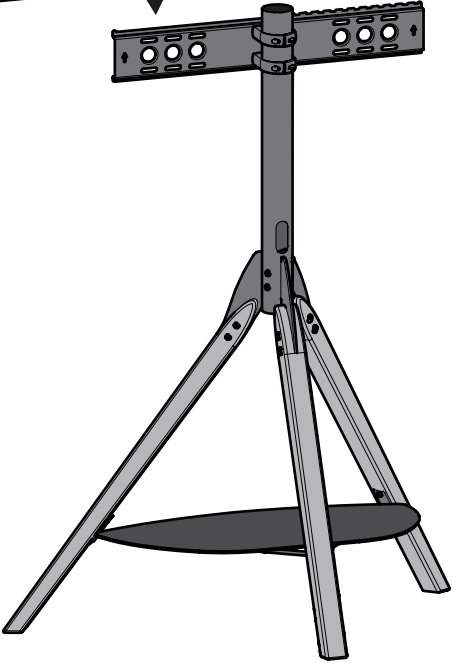
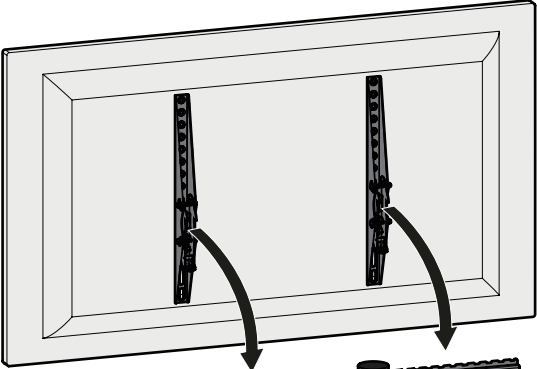
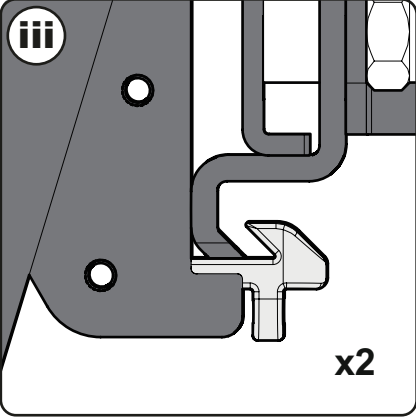
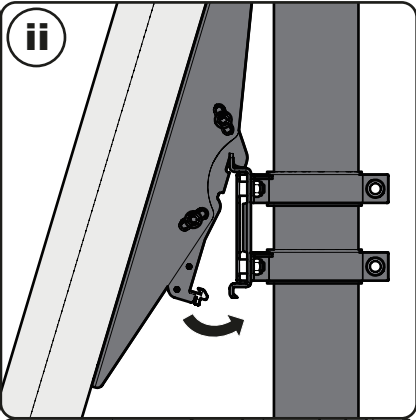
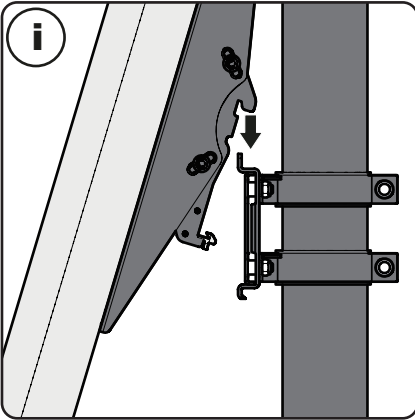

[EN] Set tilt resistance if required

[FR] Régler la résistance au basculement si nécessaire

[ES] Ajustar o aflojar para inclinar de ser necesario

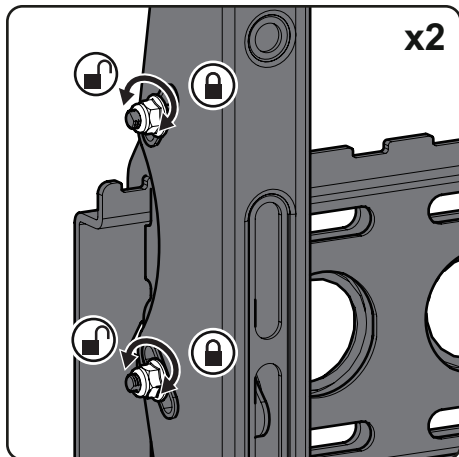

[EN] DO NOT overtighten

[FR] Ne serrez pas trop fort

[ES] No apriete demasiado

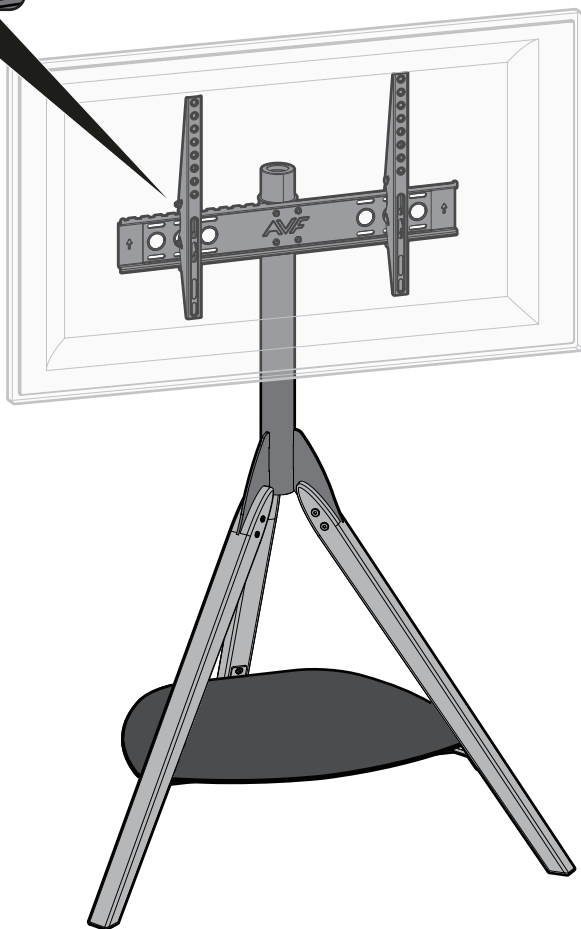

[EN] Cable Management
[FR] Gestion des Câblages
[ES] Manejo de Cable

