

**472091 Rev00**

**Please read these instructions thoroughly before installation**  
**Veillez lire attentivement ces instructions avant l'installation**  
**Por favor, lea estas instrucciones con atención antes de la instalación**



**Customer Helpline**  
**Ligne d'assistance clientèle**  
**Teléfono de atención al cliente**

**1-800 667 0808**  
**(USA)**

**+44 (0) 333 320 0463**  
**(UK)**

**Online Support**  
**Assistance en ligne**  
**Servicio técnico en línea**  
**[www.avfgroup.com/support](http://www.avfgroup.com/support)**

### **IMPORTANT INFORMATION!**

We advise that before starting the assembly of this product that you familiarise yourself with the instructions and the parts list in this leaflet.

### **INFORMATIONS IMPORTANTES!**

Nous vous recommandons de vous familiariser avec ces instructions et la liste des pièces détachées contenues dans ce document avant de commencer l'assemblage de ce produit.

### **INFORMACIÓN IMPORTANTE!**

Le recomendamos que antes de comenzar el ensamblaje de este producto se familiarize con las instrucciones y la lista de partes en esta hoja informativa.

#### **Do not's**

Do not overtighten any part of this assembly.

Do not place hot or cold objects on to or next to any surface unless the object is sufficiently insulated to prevent contact.

Do not strike any part of the stand with hard or pointed items.

Do not sit, stand or climb upon any part of this furniture.

Do not use washing powders or other substances containing abrasives when cleaning the wood or glass.

#### **À ne pas faire**

Ne serrez pas trop fort aucun des éléments de cet assemblage.

Ne placez pas d'objets chauds ou froids sur ou à côté d'une surface, sauf si l'objet est suffisamment isolés pour éviter tout contact.

Ne frappez aucune partie du support avec des objets durs ou pointus.

Ne pas vous asseoir, vous tenir debout ou grimper sur toute partie de ce meuble.

N'utilisez pas de poudres à laver ou d'autres substances contenant des abrasifs pour nettoyer le bois ou le verre.

#### **No haga**

No apriete demasiado ninguna de las piezas de este soporte.

No situar objetos calientes o fríos sobre o al lado de cualquier superficie a menos que el objeto esté suficientemente aislado para evitar el contacto.

No golpear ninguna parte del soporte con objetos duros o afilados.

No se sienta ni se pare ni se suba sobre ninguna parte de este mobiliario.

No usar detergentes u otras sustancias que contengan elementos abrasivos al limpiar la madera o el cristal.

#### **Do's**

Do use a soft cloth with a suitable furniture polish when cleaning wooden panels.

Do use a damp cloth with diluted washing up liquid for cleaning the glass surfaces.

Check all nuts and bolts from time to time.

#### **À faire**

Utilisez un chiffon doux avec un produit adapté pour le nettoyage des meubles afin de nettoyer les panneaux en bois.

Utilisez un chiffon humide imprégné de liquide vaisselle dilué pour le nettoyage des surfaces en verre.

Vérifiez tous les écrous et les boulons de temps à autre.

#### **Si haga**

Use un trapo suave con limpiador o embellecedor de muebles cuando limpie paneles de madera.

Use un trapo suave con líquido diluido en agua para limpiar las superficies de vidrio.

Compruebe todos los tornillos y tuercas de vez en cuando.

#### **Maximum TV weight and shelf capacities**

**Poids maximal du téléviseur et capacité de charge de l'étagère**

**Máximo peso y capacidad del estante de TV**

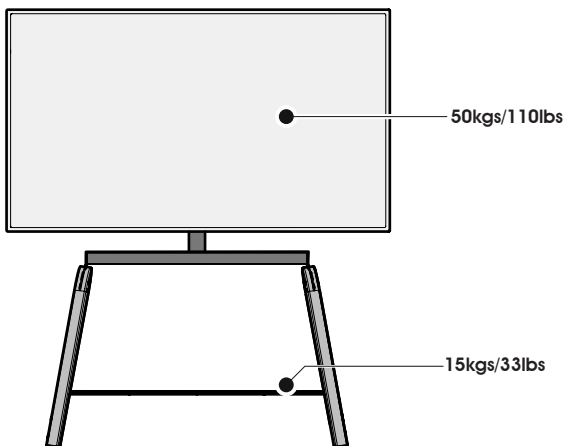

**WARNING:** Wherever possible distribute weight evenly.

**AVERTISSEMENT:** Répartissez le poids de manière uniforme lorsque cela est possible.

**ADVERTENCIA:** En la medida de lo posible distribuya el peso uniformemente.

**Boxed Parts**  
*Pièces empaquetées*  
**Piezas en la Caja**

**Tools Recommended**  
*Outils recommandés*  
**Herramientas recomendadas**

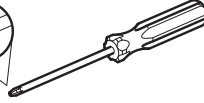

**N**



**R**



**T**

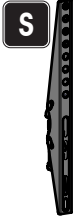

**S**



**Q**

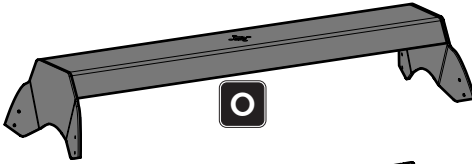

**O**

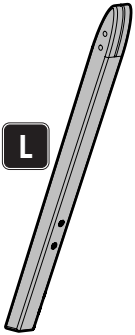

**L**



**L**



**L**



**L**



**U**

X2



**P**

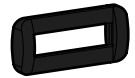

**V**

X2

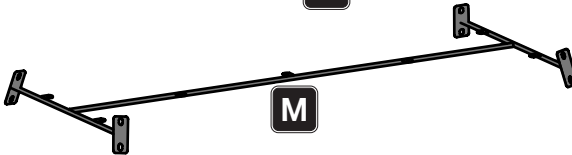

**M**



**W**

X6



**A**  
X7

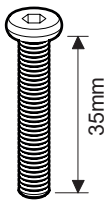

**B**  
M6  
X8

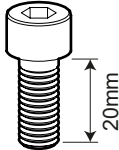

**C**  
M8  
X6

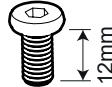

**D**  
M6  
X8



**E**  
X8

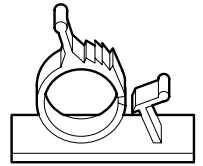

**F**  
X6

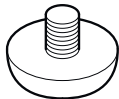

**G**  
X4

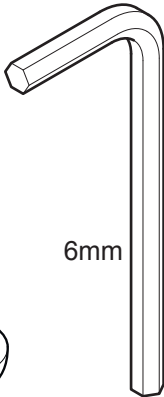

**H1**  
X1



**H2**  
X1

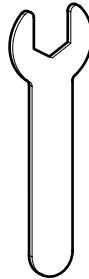

**I**  
M6  
X1

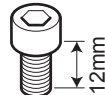

**J**  
M6  
X4



**K**  
M6  
X4

**TV Screws, Reducers and Spacers**  
*Vis TV, réducteurs et séparateurs*  
**Tornillos, Reductores y Espaciadores para TV**



**RE1** x4



**RE2** x4



**SP1** x4

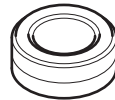

**SP2** x4



**M4**  
**TV1** x4

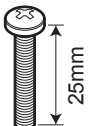

**M4**  
**TV2** x4

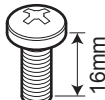

**M6**  
**TV3** x4

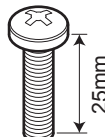

**M6**  
**TV4** x4

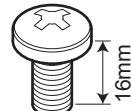

**M8**  
**TV5** x4

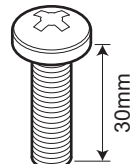

**M8**  
**TV6** x4

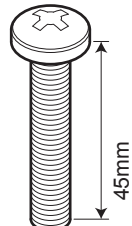

**M8**  
**TV7** x4

**Measure the TV fixing holes Width and Height**  
**Mesurer la profondeur et la taille des trous de fixation**  
**Mida los orificios de su TV, lo ancho y lo alto**

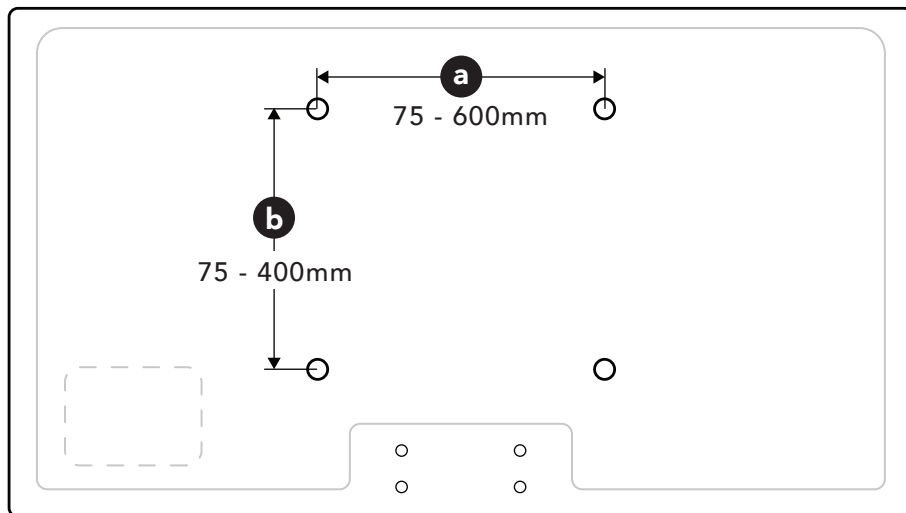

If width **a** is greater than 600mm or height **b** greater than 400mm STOP installation now and contact the customer helpline.



*Si la largeur **a** est plus large que 600mm et la hauteur **b** plus grande que 400mm, ARRÊTEZ l'installation immédiatement et contactez l'assistance client.*

Si la anchura **a** es mayor que 600mm o la altura de **b** es mayor que 400mm DETENGA la instalación inmediatamente y póngase en contacto con la línea de ayuda al cliente.

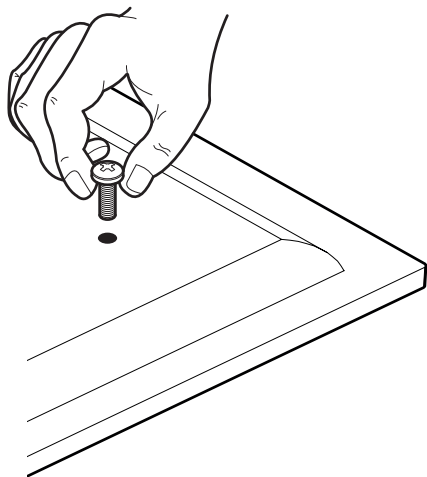

Determine which diameter TV Screws fit your TV and put them to one side.

**M4, M6 or M8**

We will select the correct length later.

*Déterminez le diamètre des vis TV adapté à votre téléviseur et mettez-les de côté.*

**M4, M6 or M8**

*Nous sélectionnerons la longueur correcte plus tard.*

Determine qué diámetro de los tornillos de TV son aptos para su TV y colóquelos en un lado.

**M4, M6 or M8**

Seleccionaremos la longitud correcta más adelante.

1

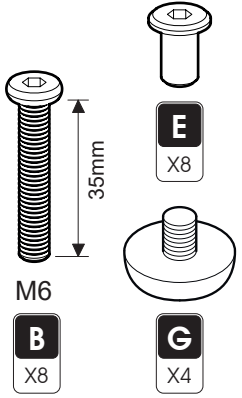
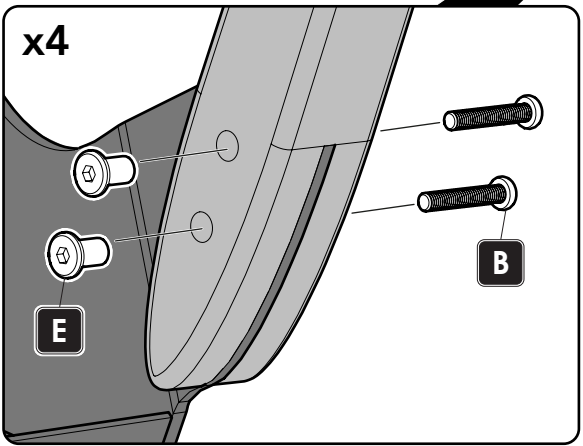
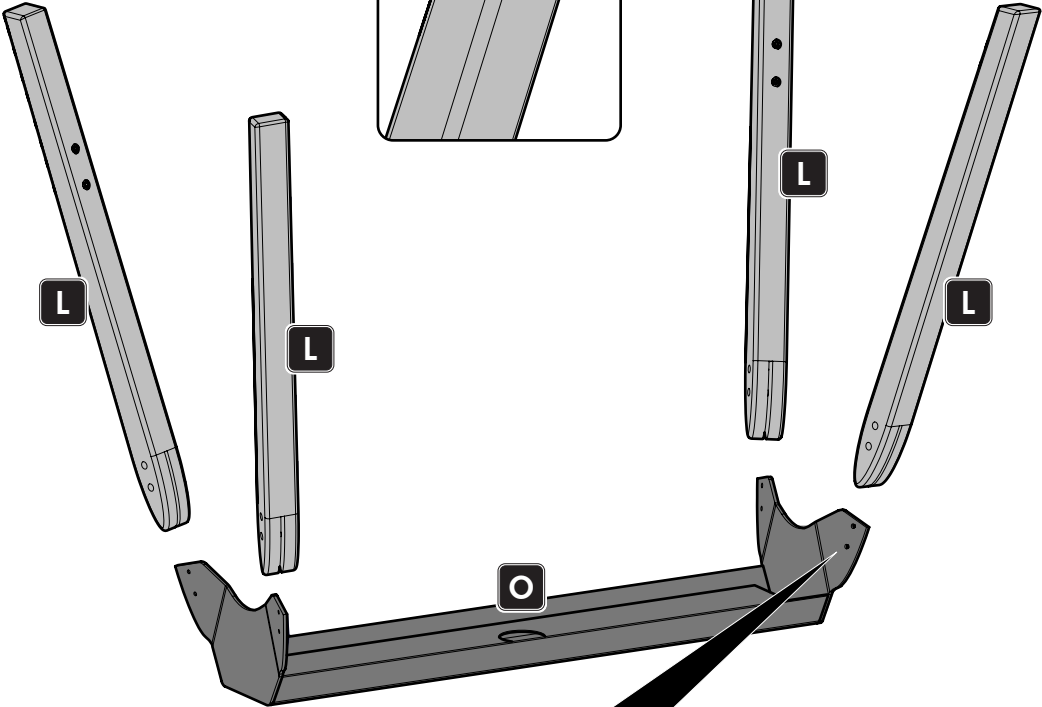
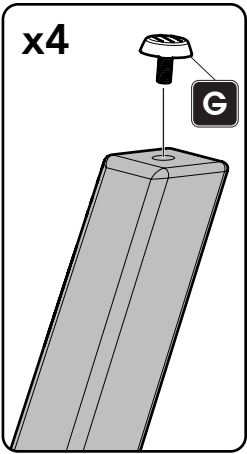

2

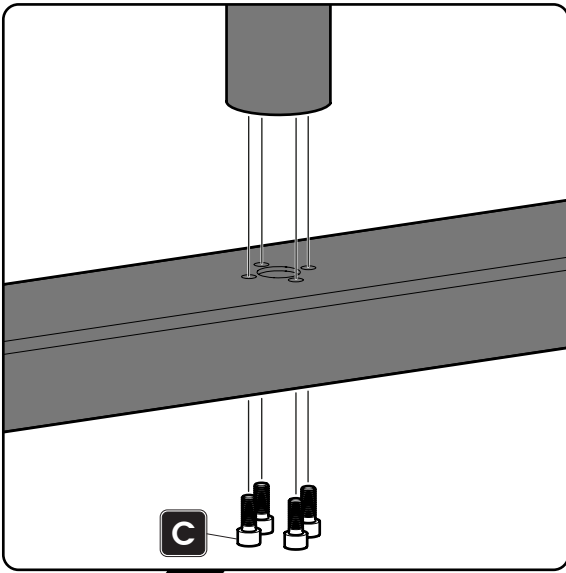

N

C

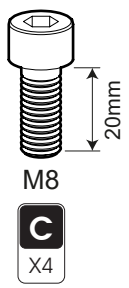
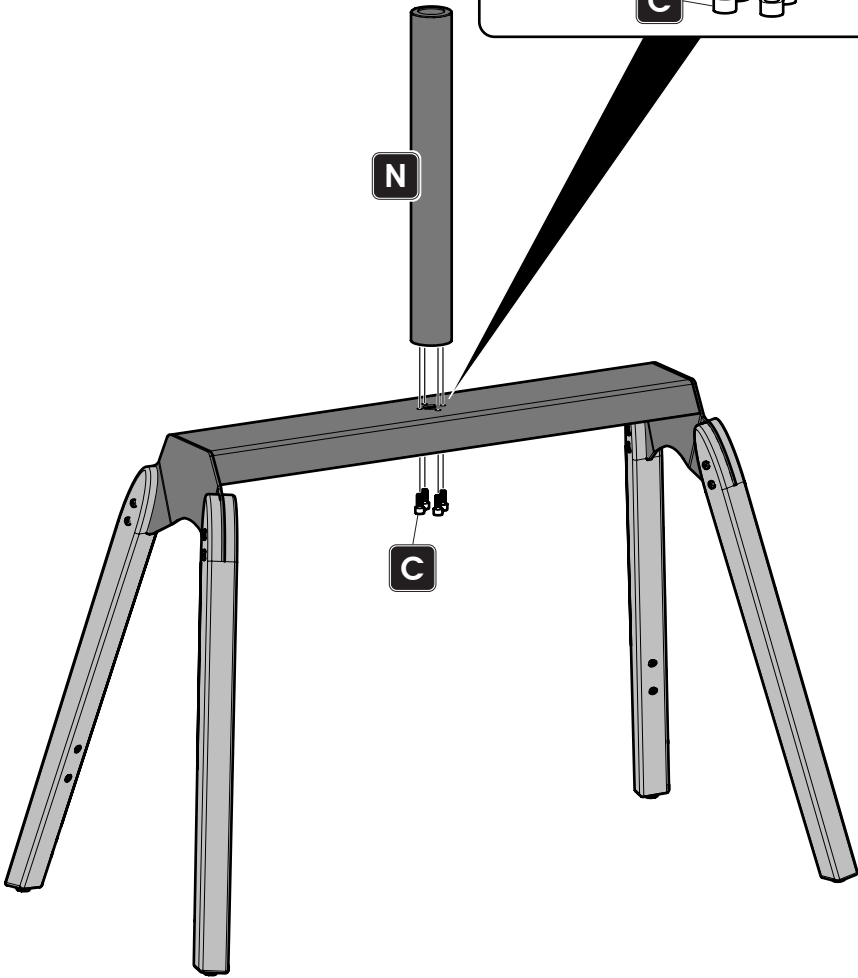

3

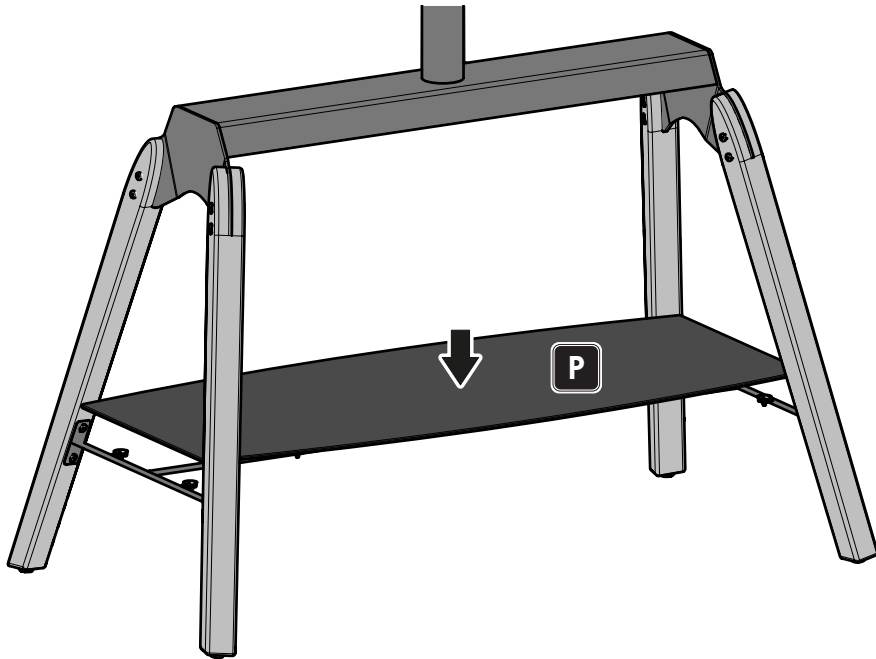
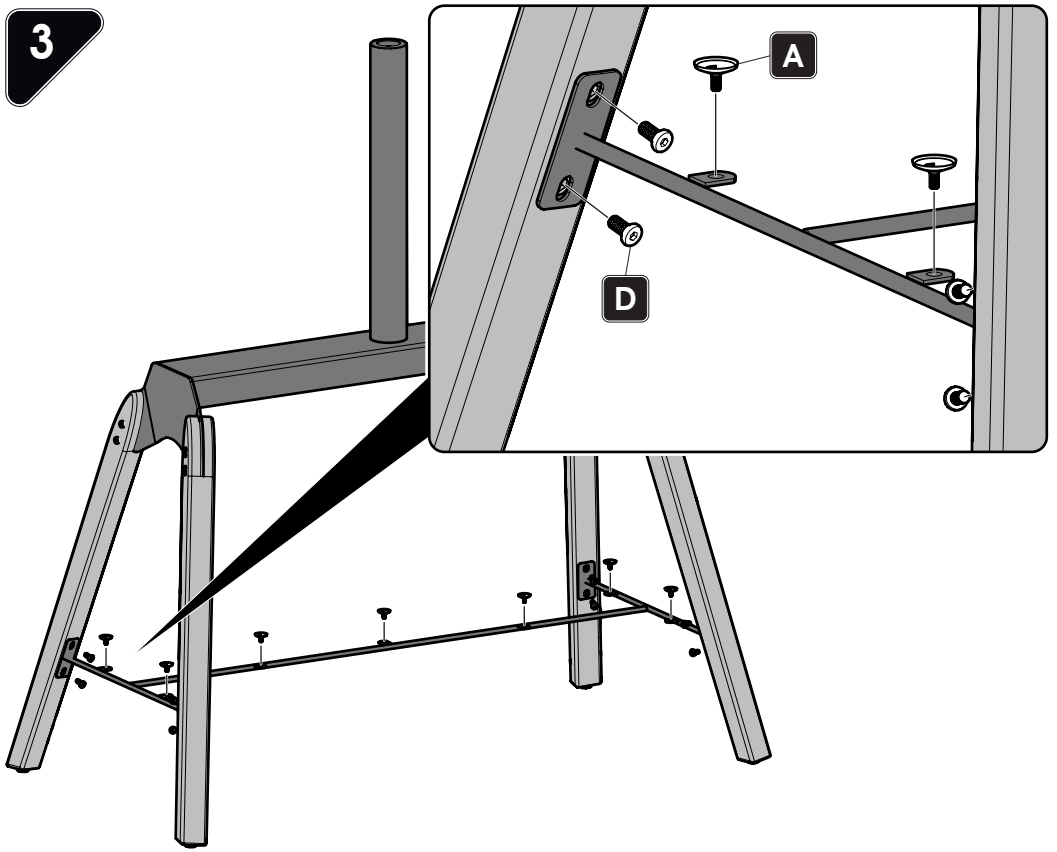

**A**  
X7

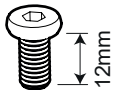

M6

12mm

**D**  
X8



4

i

After completing this step, you will have lots of TV screws left over. Keep them in a safe place in case you require them in future.

*Après avoir effectué cette étape, il vous restera de nombreuses vis de téléviseur. Gardez-les dans un endroit sûr au cas où vous en auriez besoin dans le futur.*

Después de completar este paso, quedarán muchos tornillos de TV.

Guárdelos en un lugar seguro por si los necesita en el futuro.

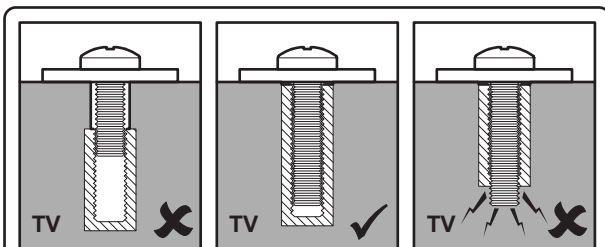
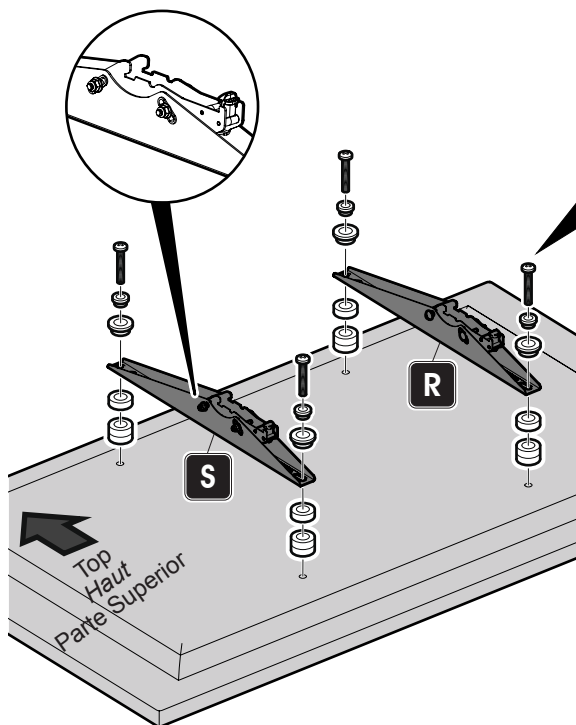

Select the correct length TV screw.  
Sélectionnez la longueur correcte de la vis TV.  
Seleccione el tornillo de TV de la longitud correcta.

TV1 - TV7

	TV1 - TV2	TV3 - TV4	TV5 - TV7
RE1	✓	✗	✗
RE2	✓	✓	✗

Do you need RE1 or RE2?  
Avez-vous besoin de RE1 ou RE2?  
Necesitas RE1 o RE2?

SP2 If required  
Si nécessaire  
SP1 Si se requiere

You may need to use Spacers **SP1** or **SP2** if the screws are too long or the back of your TV is not flat.

*Vous devrez peut-être utiliser l'entretoise **SP1** ou **SP2** si les vis sont trop longues ou si l'arrière de votre téléviseur n'est pas plat.*  
Es posible que deba usar Spacers **SP1** o **SP2** si los tornillos son demasiado largos o si la parte posterior de su televisor no está plana.

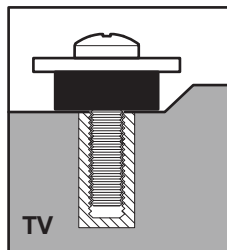

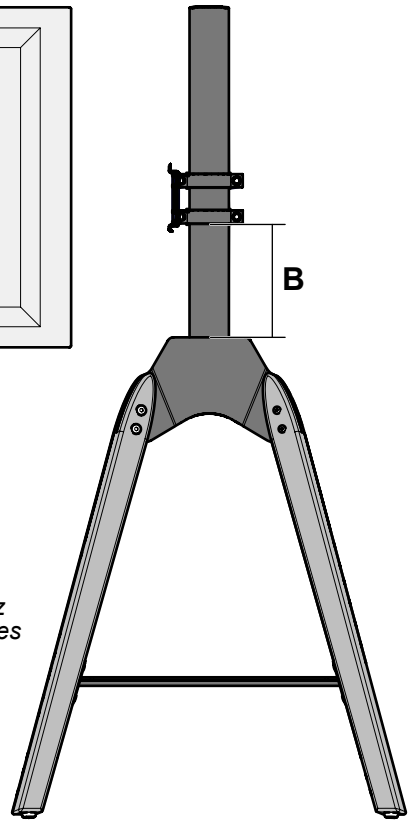
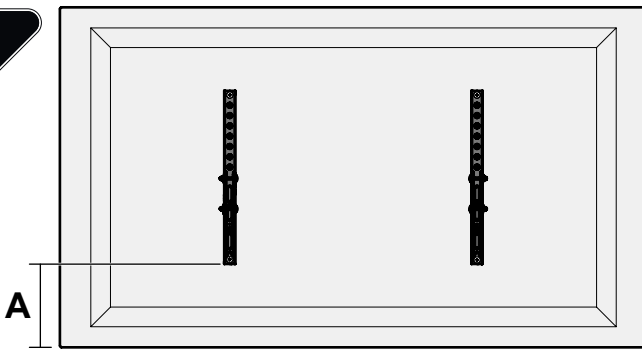
**5**

To work out the minimum height you can mount your TV, measure from the bottom of the TV Brackets to the bottom of your TV in mm (**A**).

$$B = A - 44 \text{ mm}$$

Fix the collars to the column so that the bottom edge of the lower collar is **B** mm from the base of the column.

*Pour déterminer la hauteur minimale à laquelle vous pouvez installer votre téléviseur, mesurez la distance entre le bas des supports TV et le bas de votre téléviseur, en mm (**A**).*

$$B = A - 44 \text{ mm}$$

*Fixez les collerines à la colonne de sorte que le bord inférieur du collier inférieur soit à **B** mm de la base de la colonne.*

Para calcular la altura mínima a la que puede montar su televisor, mida desde la parte inferior de los soportes de TV hasta la parte inferior de su televisor en mm (**A**).

$$B = A - 44 \text{ mm}$$

Fije los collarines a la columna de modo que el borde más bajo del collarín inferior esté a **B** mm de la base de la columna.

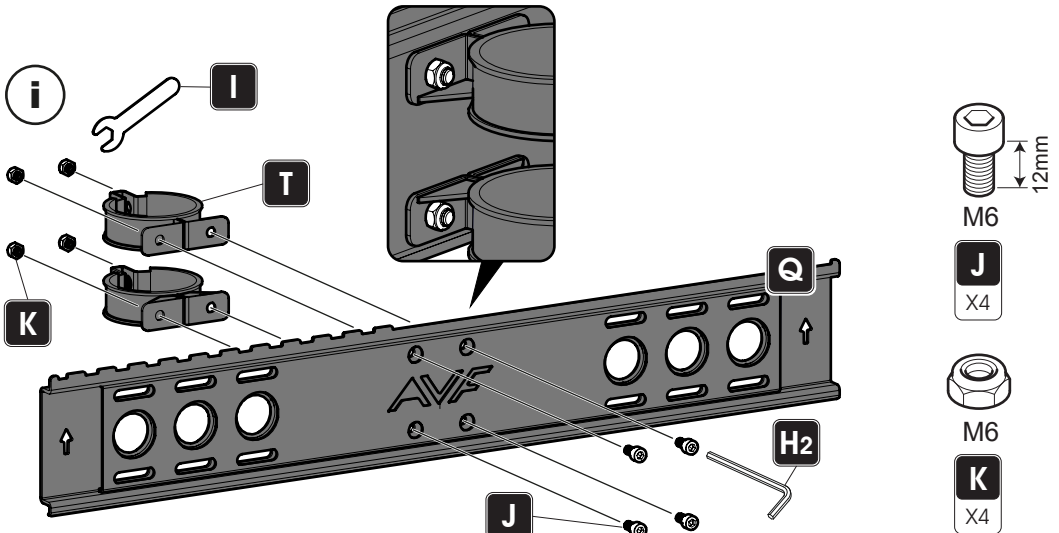

ii

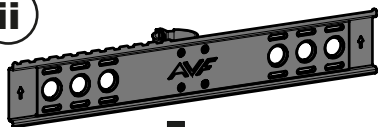

iii

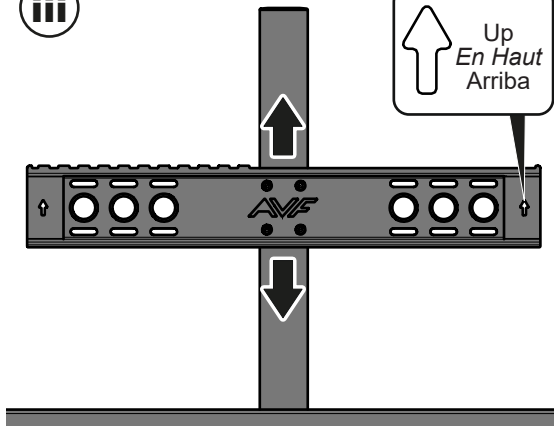

Up  
En Haut  
Arriba

iv

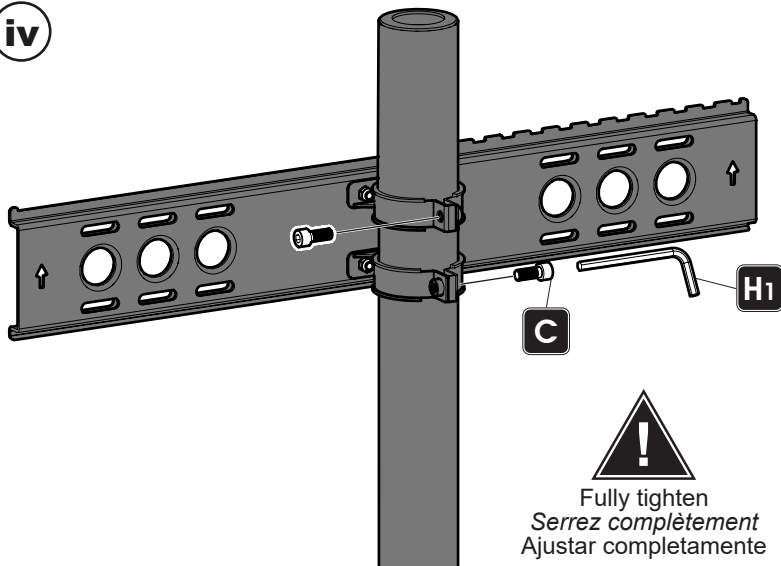

  
Fully tighten  
Serrez complètement  
Ajustar completamente

v

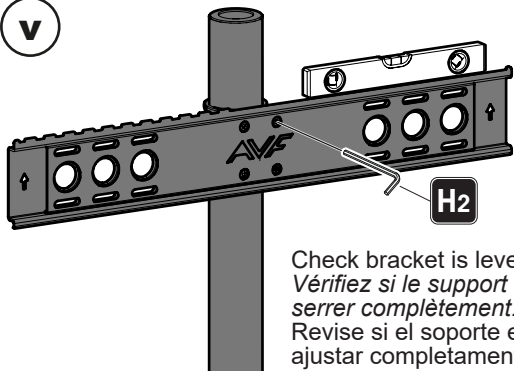

Check bracket is level before fully tightening.  
Vérifiez si le support est au niveau, avant de  
serrer complètement.  
Revise si el soporte está nivelado antes de  
ajustar completamente.

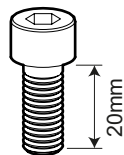

M8

  
X2

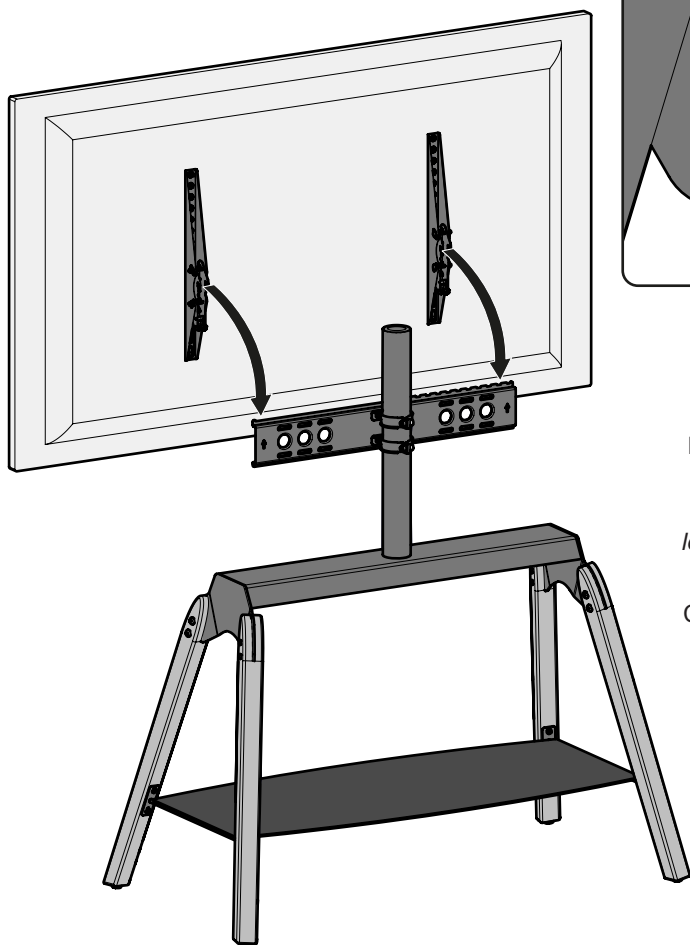
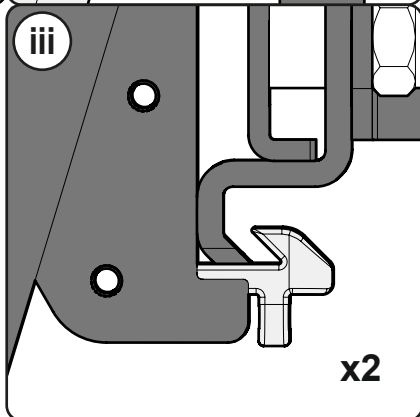
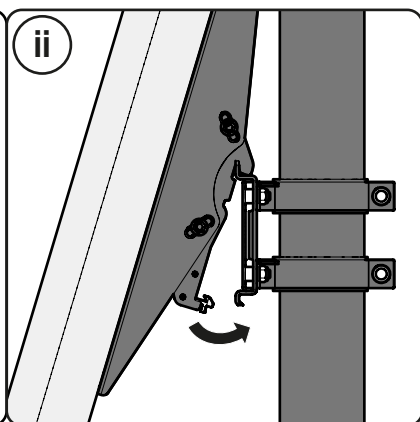
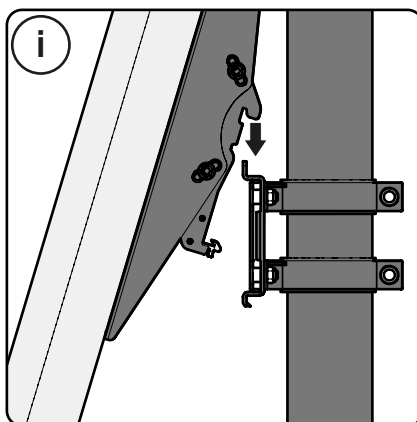
**6**

Place a protective cloth over the legs when hanging the TV to avoid any accidental damage.  
*Placez un tissu protecteur sur les pieds lorsque vous accrochez le téléviseur pour éviter tout dommage accidentel.*  
Coloque un paño protector sobre las patas cuando cuelgue el televisor para evitar cualquier daño accidental.

Set tilt resistance if required  
*Régler la résistance au basculement si nécessaire*  
Ajustar o aflojar para inclinar de ser necesario

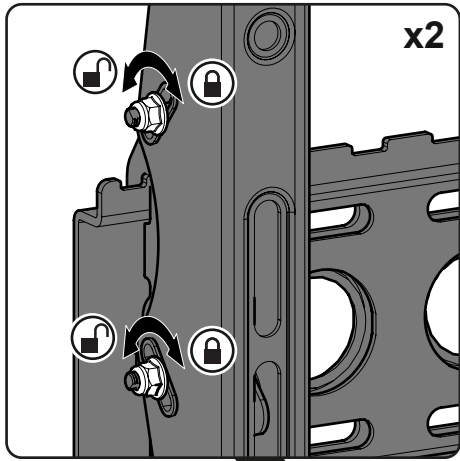

DO NOT overtighten  
*Ne serrez pas trop fort*  
No apriete demasiado

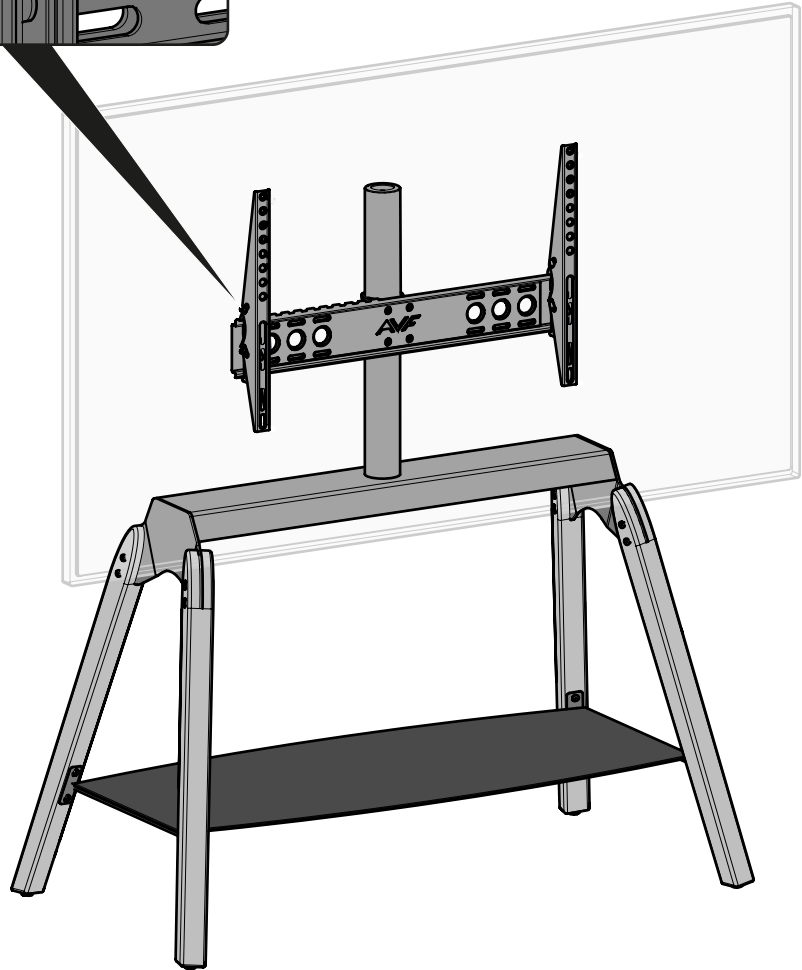

**Cable Management**  
*Gestion des Câblages*  
**Manejo de Cable**

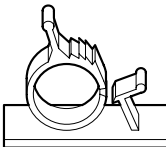
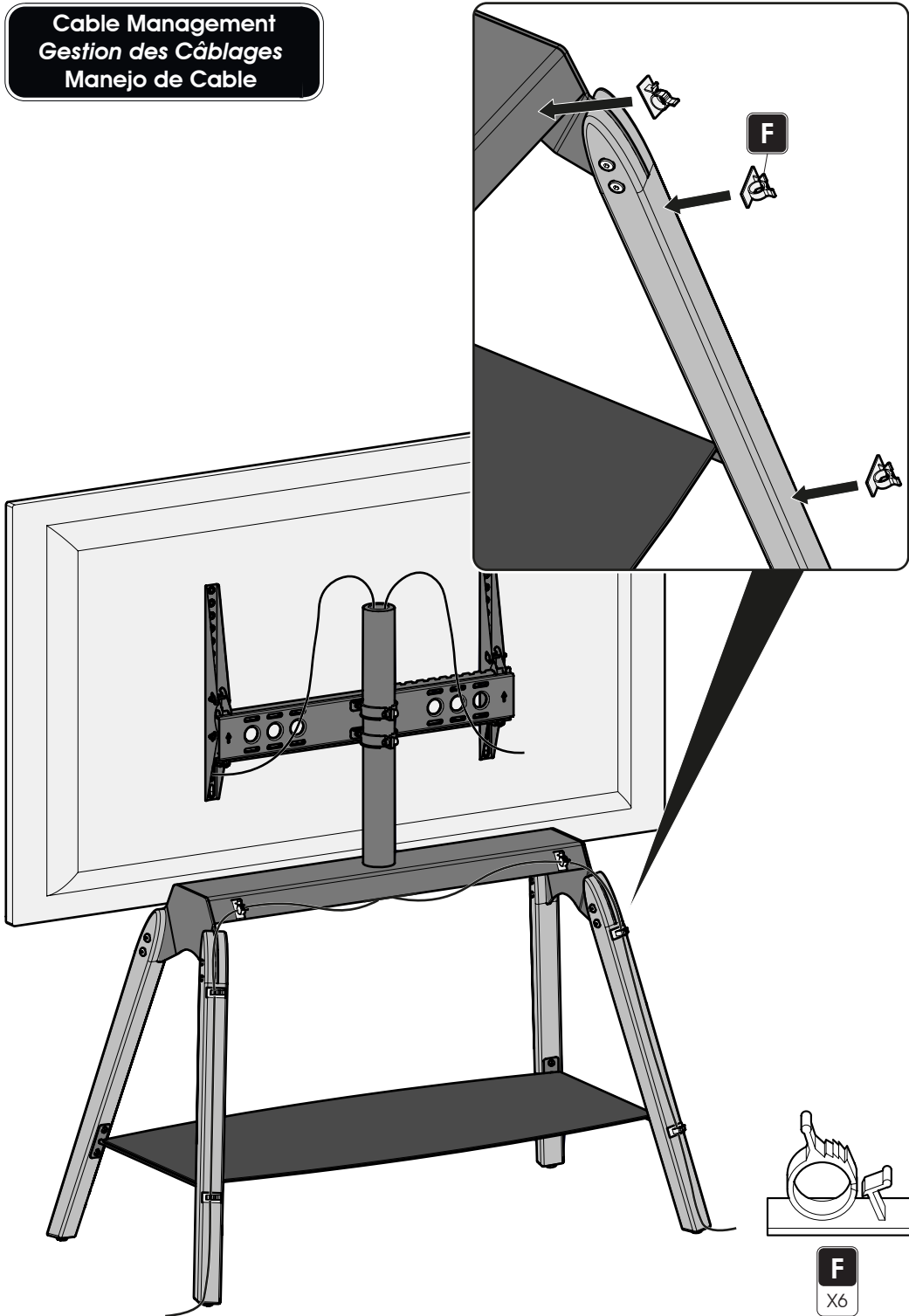

**F**  
X6

**Hook and Loop Device Pads**  
**Tampons pour appareils à crochets et boucles**  
**Almohadillas de velcro para dispositivos**

Use the Hook and Loop Pads provided to secure small devices to the rear support shelf.

*Utilisez les coussinets auto-agrippants fournis pour fixer les petits appareils à l'étagère de support arrière.*

Utilice las almohadillas de velcro suministradas para fijar los dispositivos pequeños al estante de soporte trasero.

- i.** Separate the Hook and Loop strips. Peel off the coating to reveal the adhesive tape.  
*Séparez les bandes à crochet et à boucle. Décollez le revêtement pour faire apparaître le ruban adhésif.*  
Separe las tiras de velcro. Retire el revestimiento para utilizar la cinta adhesiva.

- ii.** Stick one strip to the underside of your device.  
*Collez une bande sur la face inférieure de votre appareil.*  
Pegue una tira en la parte inferior del dispositivo.

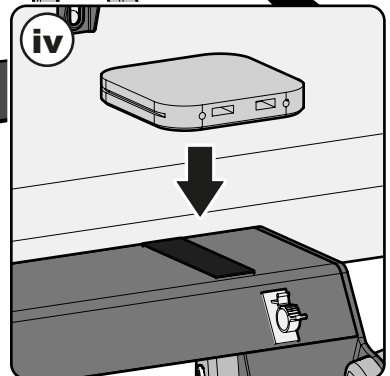
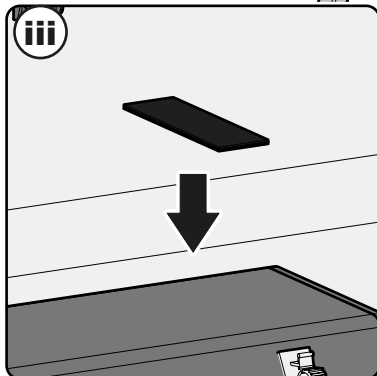
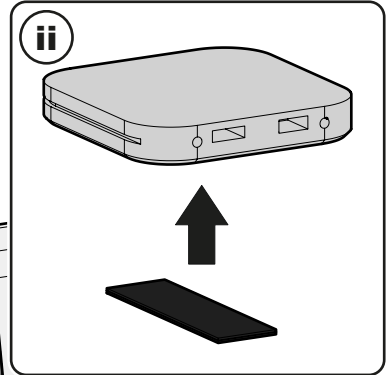
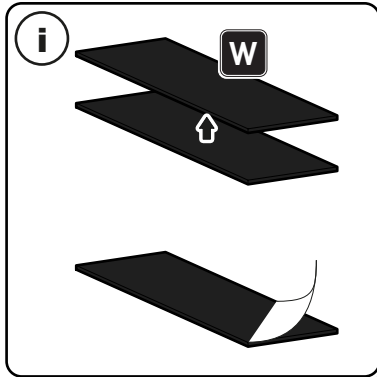

- iii.** Stick the other strip to the rear support shelf.  
*Collez l'autre bande sur l'étagère de support arrière.*  
Pegue la otra tira al estante de soporte trasero.

- iv.** Attach your device.  
*Connectez votre appareil.*  
Conecte su dispositivo.

**Hook and Loop Soundbar Strap**  
**Sangle de barre audio auto-agrippante**  
**Correa de velcro para barra de sonido**

Use the Hook and Loop Soundbar Straps provided to hang your Soundbar below the rear support shelf.

*Utilisez les sangles auto-agrippantes fournies pour suspendre votre barre audio sous l'étagère de support arrière.*

Usa las correas de velcro para barra de sonido incluidas para colgar la barra de sonido por debajo del estante de soporte trasero.

- i.** Loop the Soundbar Strap **U** over the rear support shelf and secure by folding back on itself through the plastic buckle **V**.

*Enroulez la sangle de la barre audio sur l'étagère de support arrière et fixez-la en la repliant sur elle-même à l'aide de la boucle en plastique.*

Coloque la correa de la barra de sonido sobre el estante de soporte trasero y asegúrela doblándola sobre sí misma a través de la hebilla de plástico.

- ii.** Make sure both straps are the same length by making the folded lengths equal.

*Assurez-vous que les deux sangles ont la même longueur en faisant en sorte que les longueurs pliées soient égales.*

Asegúrese de que ambas correas tengan la misma longitud haciendo que las longitudes dobladas sean iguales.

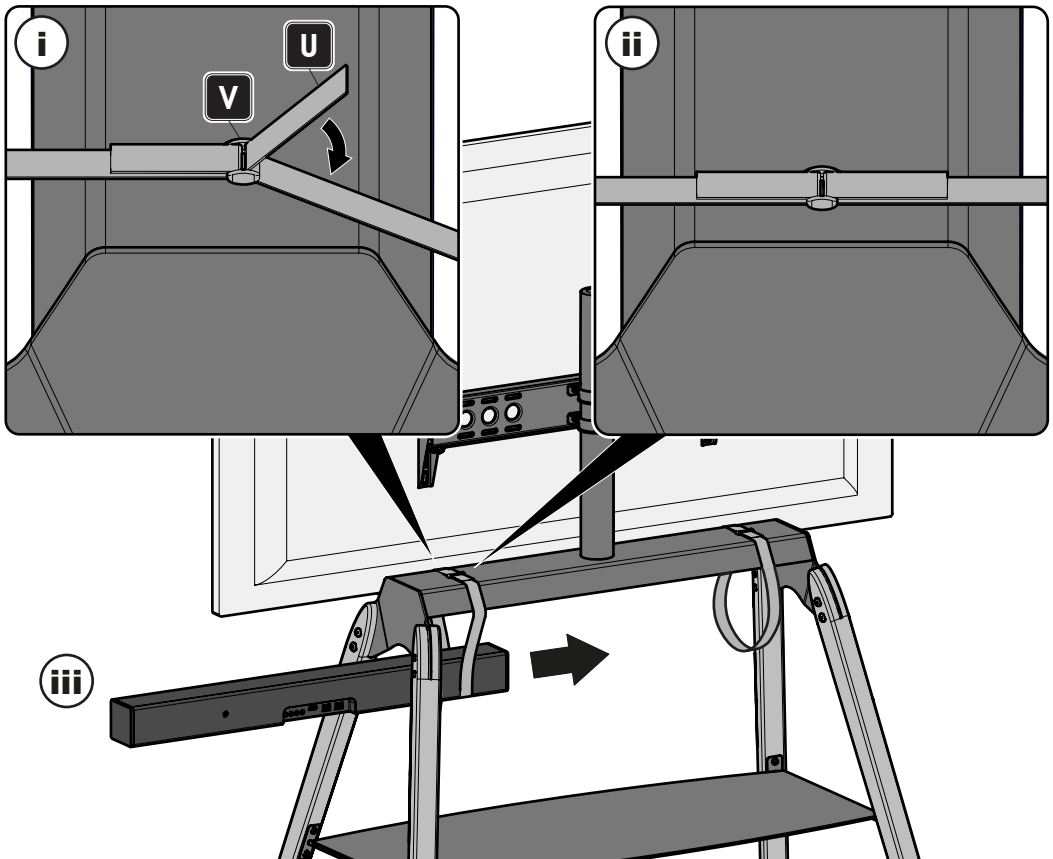

- iii.** Slide your Soundbar through both straps to hang below the rear support shelf. You can adjust the straps to achieve your preferred height for your Soundbar if required.

*Faites glisser votre barre audio à travers les deux sangles pour l'accrocher sous l'étagère de support arrière. Vous pouvez ajuster les sangles pour obtenir la hauteur de votre barre audio préférée si nécessaire.*

Deslice la barra de sonido a través de ambas correas para colgarla por debajo del estante de soporte trasero. Si es necesario, puede ajustar las correas para lograr la altura que prefiera para su barra de sonido.