

471583 Rev00

WICHTIGE INFORMATIONEN!

Bevor Sie mit der Montage dieses Produkts beginnen, sollten Sie sich mit den Anweisungen und der Teileliste in diesem Beipackzettel vertraut machen.

INFORMAZIONI IMPORTANTI!

Prima di iniziare l'assemblaggio del prodotto, consigliamo di acquisire familiarità con le istruzioni e con la lista di componenti descritta in quest'opuscolo.

INFORMAÇÕES IMPORTANTES!

Antes de iniciar a montagem deste produto, aconselhamos que se familiarize com as instruções e a lista de peças neste folheto.

Was Sie nicht tun sollten

Ziehen Sie keine Teile dieser Baugruppe zu fest an.

Stellen Sie keine heißen oder kalten Gegenstände auf oder in die Nähe von Glasflächen, es sei denn, der Gegenstand ist ausreichend isoliert, um einen Kontakt zu verhindern.

Schlagen Sie nicht mit harten oder spitzen Gegenständen gegen das Glas.

Setzen und stellen Sie sich nicht auf horizontale Glasflächen.

Verwenden Sie zum Reinigen des Glases keine Waschmittel oder andere Substanzen, die Scheuermittel enthalten.

Verwenden Sie das Produkt nicht, wenn das Glas abgebrochen oder beschädigt ist.

Da evitare

Evitare di stringere eccessivamente qualsiasi componente di questo assemblaggio.

Non collocare oggetti caldi o freddi sopra o nelle immediate vicinanze di qualsiasi superficie in vetro, a meno che l'oggetto non sia sufficientemente isolato da evitare il contatto.

Non colpire il vetro con oggetti rigidi o appuntiti.

Non sedersi o stare in piedi sulle superfici di vetro orizzontali.

Non utilizzare polveri detergenti o altre sostanze contenenti componenti abrasive in fase di pulizia del vetro.

Non utilizzare il prodotto se il vetro appare scheggiato o danneggiato.

Não

Não aperte demasiado qualquer peça desta montagem.

Não coloque objetos quentes ou frios em cima ou perto de qualquer superfície de vidro exceto se o objeto tiver um isolamento suficiente para impedir o contacto.

Não bata no vidro com itens rígidos ou pontiagudos.

Não se sente nem pise superfícies de vidro horizontais.

Não utilize detergentes em pó ou outras substâncias que contenham abrasivos ao limpar o vidro.

Não utilize este produto se o vidro estiver lascado ou danificado.

Was Sie tun sollten

Verwenden Sie zum Reinigen der Glasoberflächen ein feuchtes Tuch mit verdünntem Spülmittel.

Überprüfen Sie von Zeit zu Zeit alle Schrauben und Muttern.

Cosa fare

Per pulire le superfici in vetro, utilizzare un panno inumidito con liquido detergente diluito.

Controllare di tanto in tanto tutti i dadi e bulloni.

Faz

Utilize um pano húmido com detergente líquido diluído para limpar as superfícies de vidro.

Verifique todas as porcas e parafusos periodicamente.

Höchstgewicht des Fernsehers und Regalkapazitäten

Peso massimo del televisore e capacità dei ripiani

Peso máximo da TV e capacidades de prateleira

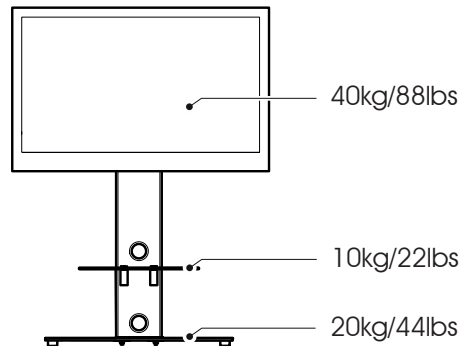

WARNHINWEIS: Wenn möglich, das Gewicht gleichmäßig verteilen.

ATTENZIONE: ove possibile, distribuire il peso uniformemente.

AVISO: Sempre que possível, distribua o peso uniformemente.

Verpackte Teile
Parti contenute nella confezione
Peças Embaladas

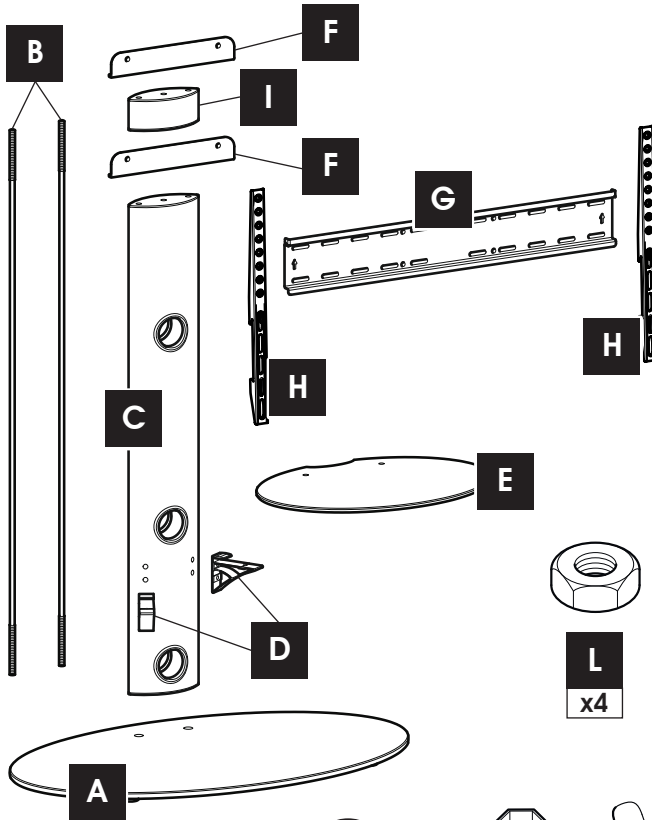

Sie brauchen
Avrai bisogno del
seguinte materiale
Precisará de

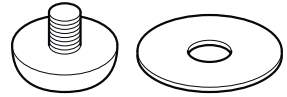
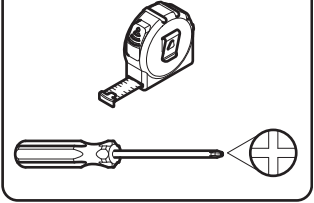

J
x4

K
x2

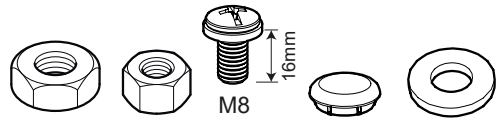

L
x4

M
x4

N
x2

O
x4

P
x2



Q
x4

R
x2

S
x1

T
x4

U
x4

W
x4

TV-Schrauben, Übergangsstücke und Abstandshalter
Viti, riduttori e distanziatori per la TV
Parafusos de TV, Redutores e Espaçadores



SP1
x4

RE1
x4

RE2
x4

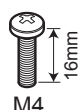

TV1
x4

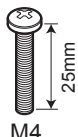

TV2
x4

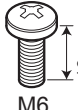

TV3
x4

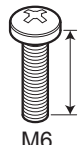

TV4
x4

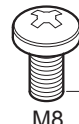

TV5
x4

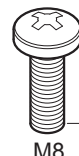

TV6
x4

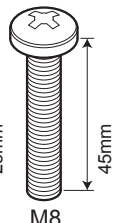

TV7
x4

1

Messen Sie die Breite und Höhe der TV-Befestigungslöcher
 Misurare la larghezza e l'altezza dei fori di fissaggio della TV
 Meça a largura e altura dos orifícios de fixação da TV

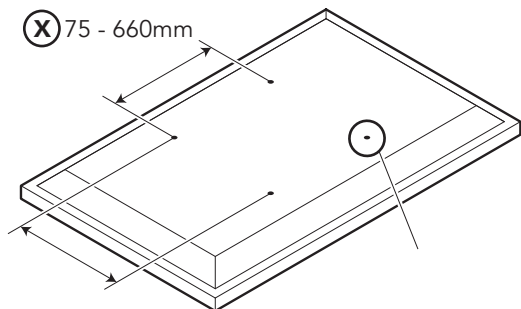

⊗ 75 - 660mm

⊙ 75 - 400mm

Wenn die Breite ⊗ größer als 660mm oder die Höhe ⊙ größer als 400mm ist, STOPPEN Sie die Installation jetzt und kontaktieren Sie die Hotline des Kundendienstes.

Se la larghezza ⊗ è superiore a 660mm oppure l'altezza ⊙ è superiore a 400mm, fermare subito l'installazione e contattare l'assistenza clienti.

Se a largura ⊗ for maior do que 660mm ou a 400mm altura ⊙ maior do que INTERROMPA já a instalação e entre em contacto com a linha de assistência ao cliente.

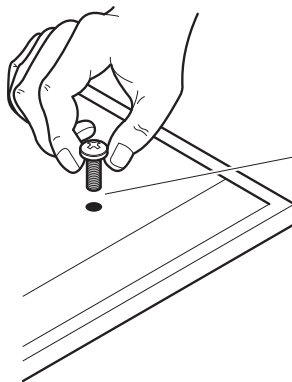

M4 = TV1-2

M6 = TV3-4

M8 = TV5-7

Im Lieferumfang des Produkts sind Schrauben zur Befestigung des Fernsehgeräts in 3 verschiedenen Durchmessern verfügbar, **M4**, **M6** und **M8**. Ermitteln Sie den richtigen Schraubendurchmesser und halten Sie ihn für Schritt 9 fest.

Ti saranno fornite viti di fissaggio per TV con 3 diametri differenti, **M4**, **M6** e **M8**. Stabilisci il diametro della vite che si adatta e tienilo a mente per il passaggio n. 9.

São lhe fornecidos parafusos de fixação de TV de 3 diâmetros, **M4**, **M6** e **M8**. Descubra qual o diâmetro de parafuso que encaixa e memorize-o para o passo 9.

2

Sie können das Stück Material unter das Glas legen, um Schäden zu vermeiden.

Mettere un pezzo di materiale sotto il vetro, per evitare danni.

Coloque um pedaço de material por baixo do vidro para evitar danos.

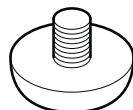
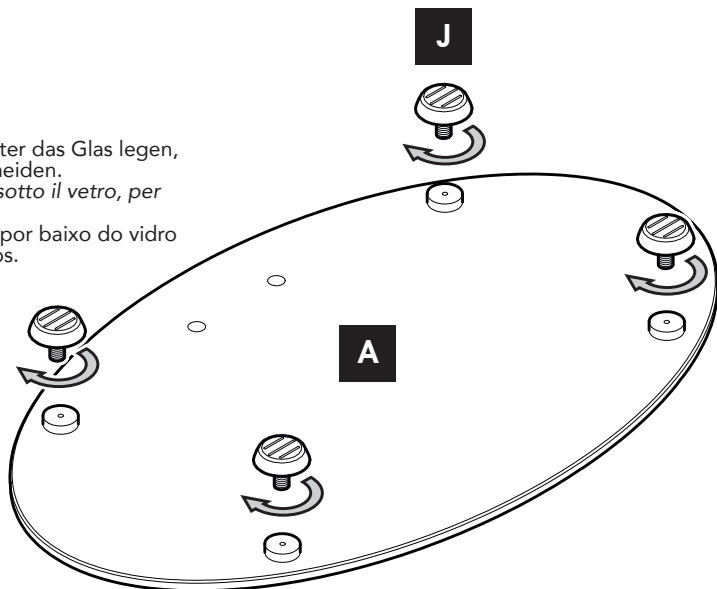
**J****x4**

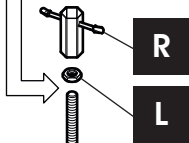
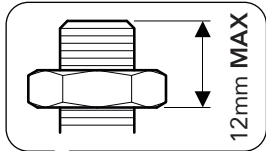
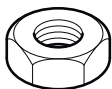
4**x2****R****L****B****L****x2****5**

Bitte berücksichtigen Sie die Größe Ihres Fernsehgeräts, bevor Sie Platte F befestigen. Siehe Anleitung.

Prima di fissare la piastra F, tenere in considerazione le dimensioni della propria TV. Consultare le informazioni che seguono per avere una guida.

Por favor, considere o tamanho da sua TV antes de fixar a placa F. Veja o guia abaixo.

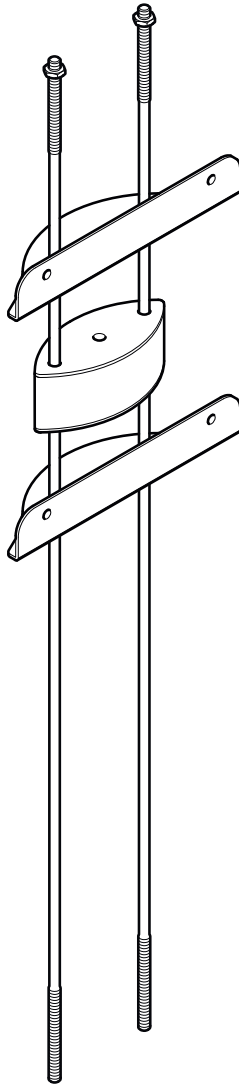

Empfohlen für mittlere bis große Fernseher.
Consigliato per TV di dimensioni medio-grandi.
 Recomendado para uma TV de tamanho Médio a Grande.

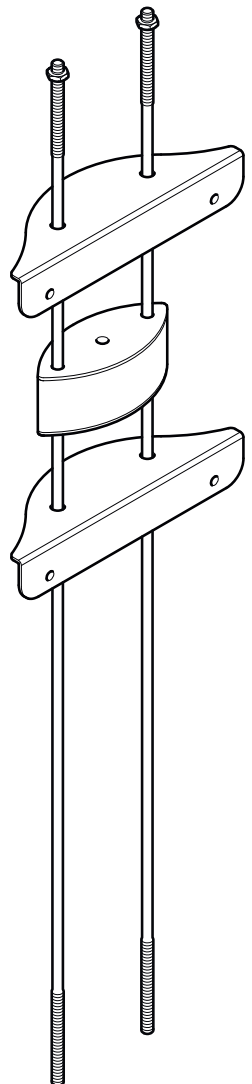

Empfohlen für große bis extragroße Fernseher.
Consigliato per TV di dimensioni grandi o extra-grandi.
 Recomendado para uma TV de tamanho Grande a Extragrande.

6

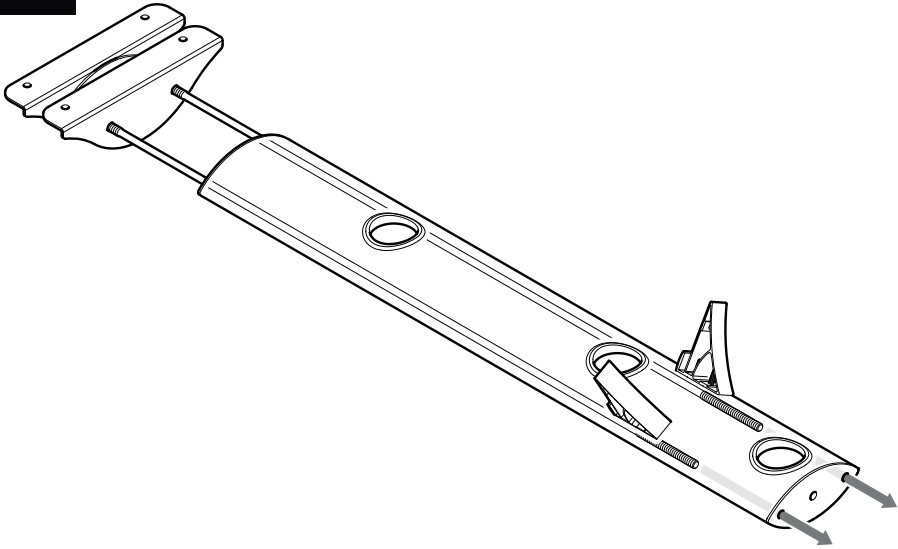

7



R



NICHT zu fest anziehen
NON stringere troppo
NÃO aperte em excesso

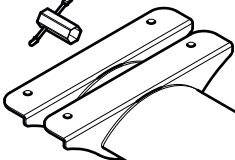

K
x2

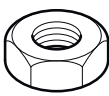

L
x2

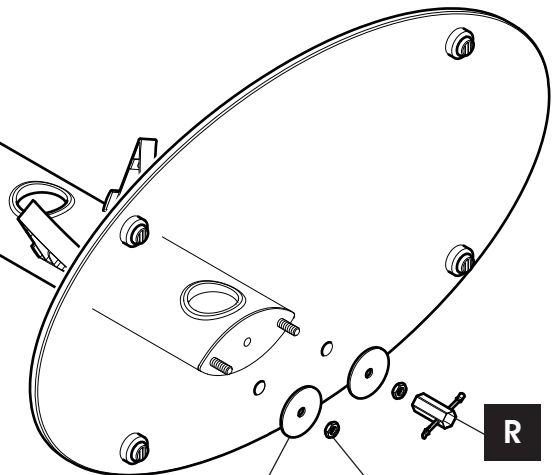

K

L

R

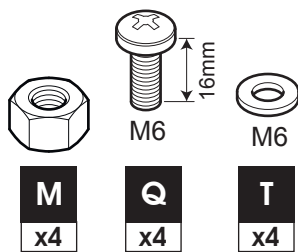
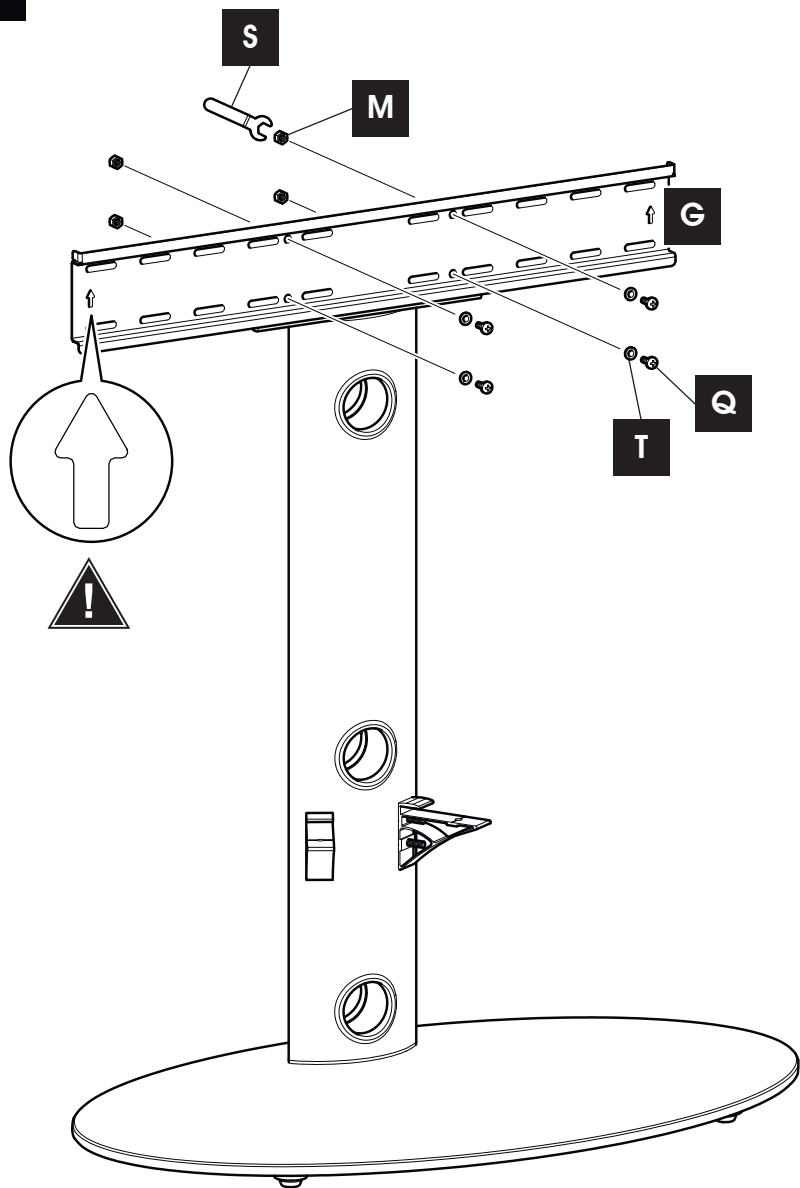

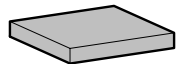
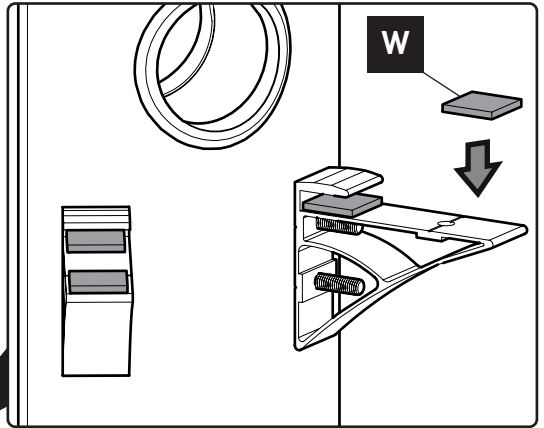
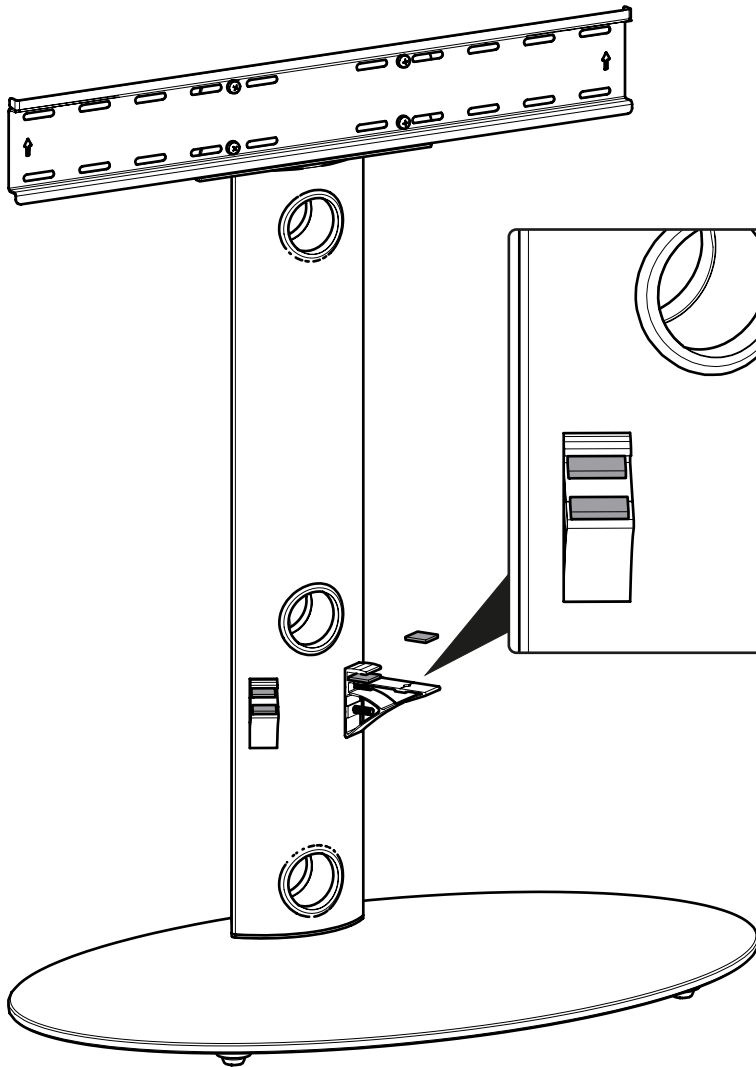

W
x4



NICHT zu fest anziehen
NON stringere troppo
NÃO aperte em excesso

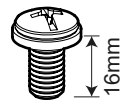
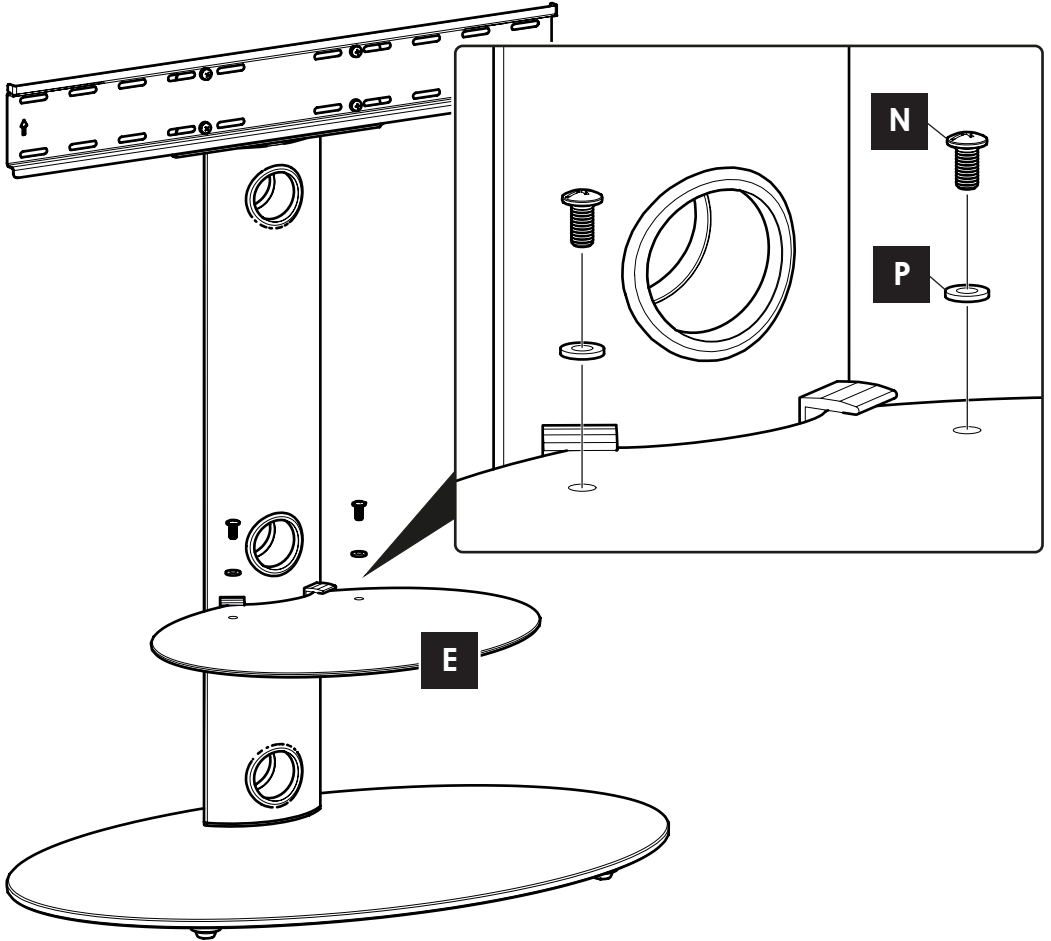

M8

N

x2

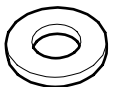

P

x2

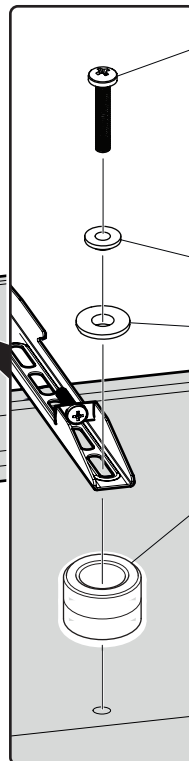
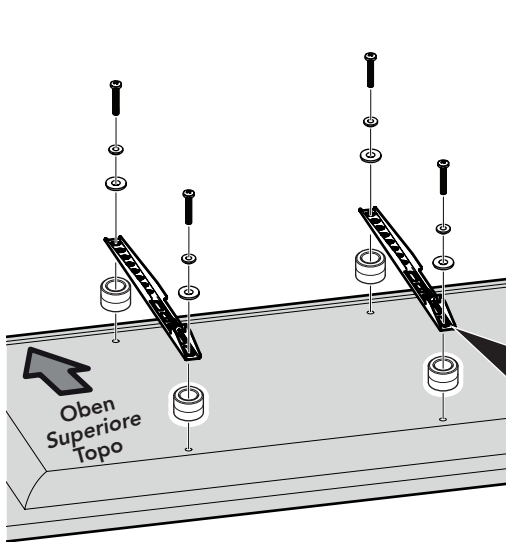
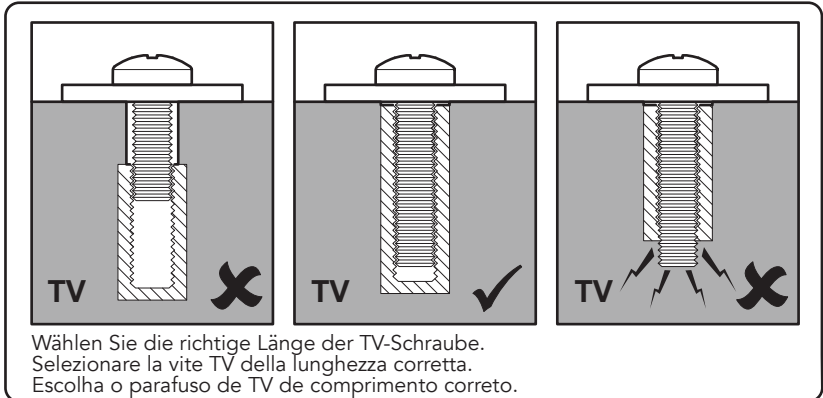

	TV1-TV2	TV3-TV4	TV5-TV7
RE1	✓	✗	✗
RE2	✓	✓	✗

Benötigen Sie RE1 oder RE2?
 Si necessita di RE1 o RE2?
 Precisa de RE1 ou RE2?

SP1] Falls erforderlich
 Se necessario
 Se necessário

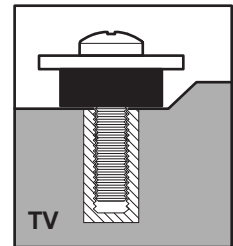

Möglicherweise müssen Sie den Abstandshalter **SP1** verwenden, wenn die Schrauben zu lang sind oder die Rückseite Ihres Fernsehers nicht eben ist. Potrebbe essere necessario utilizzare Spacer **SP1** se le viti sono troppo lunghe o il retro del televisore non è piatto. Se os parafusos forem muito longos ou a parte posterior da sua TV não for plana, pode ter de utilizar o Espaçador **SP1**.



Nachdem Sie diesen Schritt abgeschlossen haben, werden Sie zahlreiche Schrauben übrig haben. Bewahren Sie diese an einem sicheren Ort auf, falls Sie sie in Zukunft benötigen.

Dopo aver completato questo passaggio, ti saranno rimaste tantissime viti per la TV.

Tienile in un posto sicuro, in caso tu ne abbia bisogno in futuro.

Após concluir este passo, sobrar-lhe-ão muitos parafusos de TV. Guarde-os num local seguro, caso precise deles no futuro.

