

# 470064 Rev01

Please read these instructions thoroughly  
before installation.

VESA  
600 x 400mm  
Max



Max

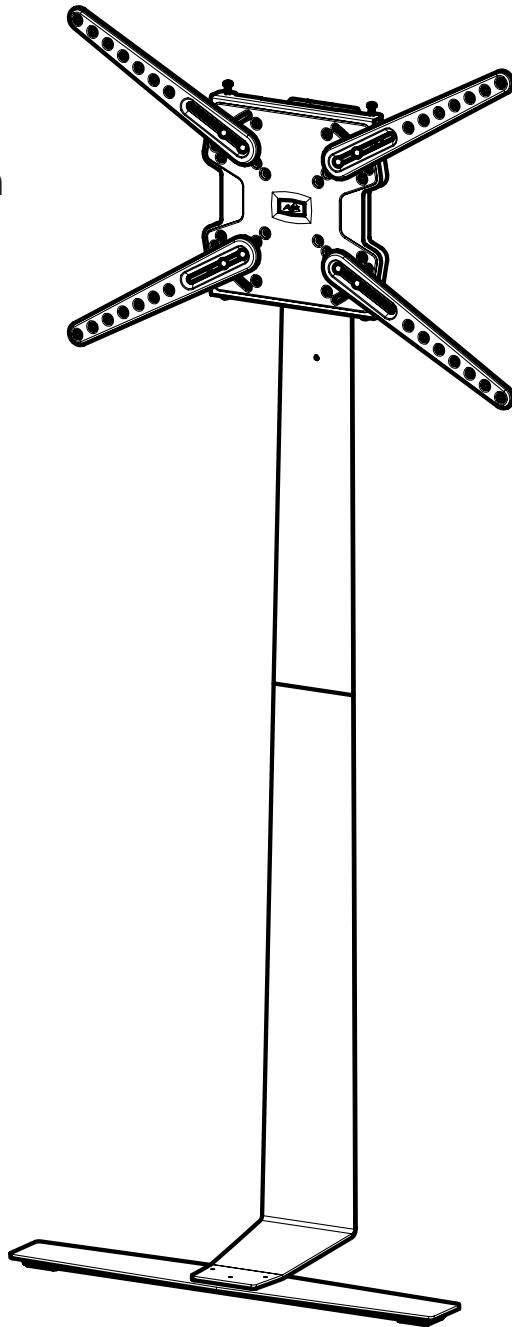

If you have any questions or need  
spare parts don't worry, we're happy to help.

## You will need

### Required

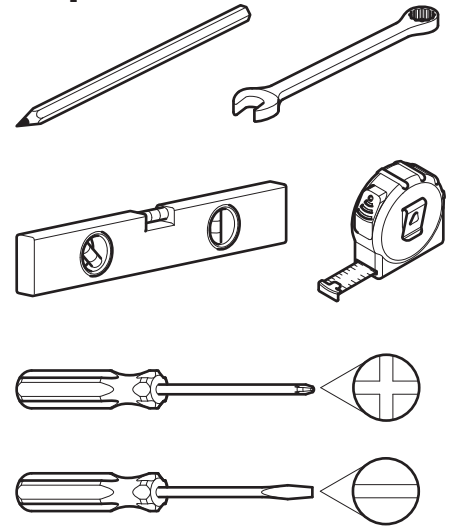

### Optional

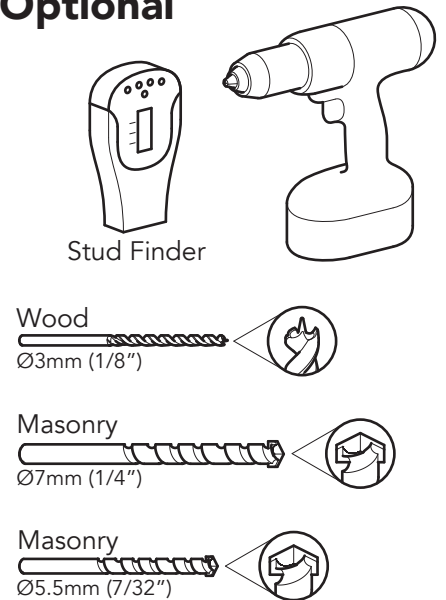

## Customer Helpline

1-800 667 0808  
(USA)

+44 (0) 333 320 0463  
(UK)

## Online Support

[www.avfgroup.com/support](http://www.avfgroup.com/support)

# Parts Included

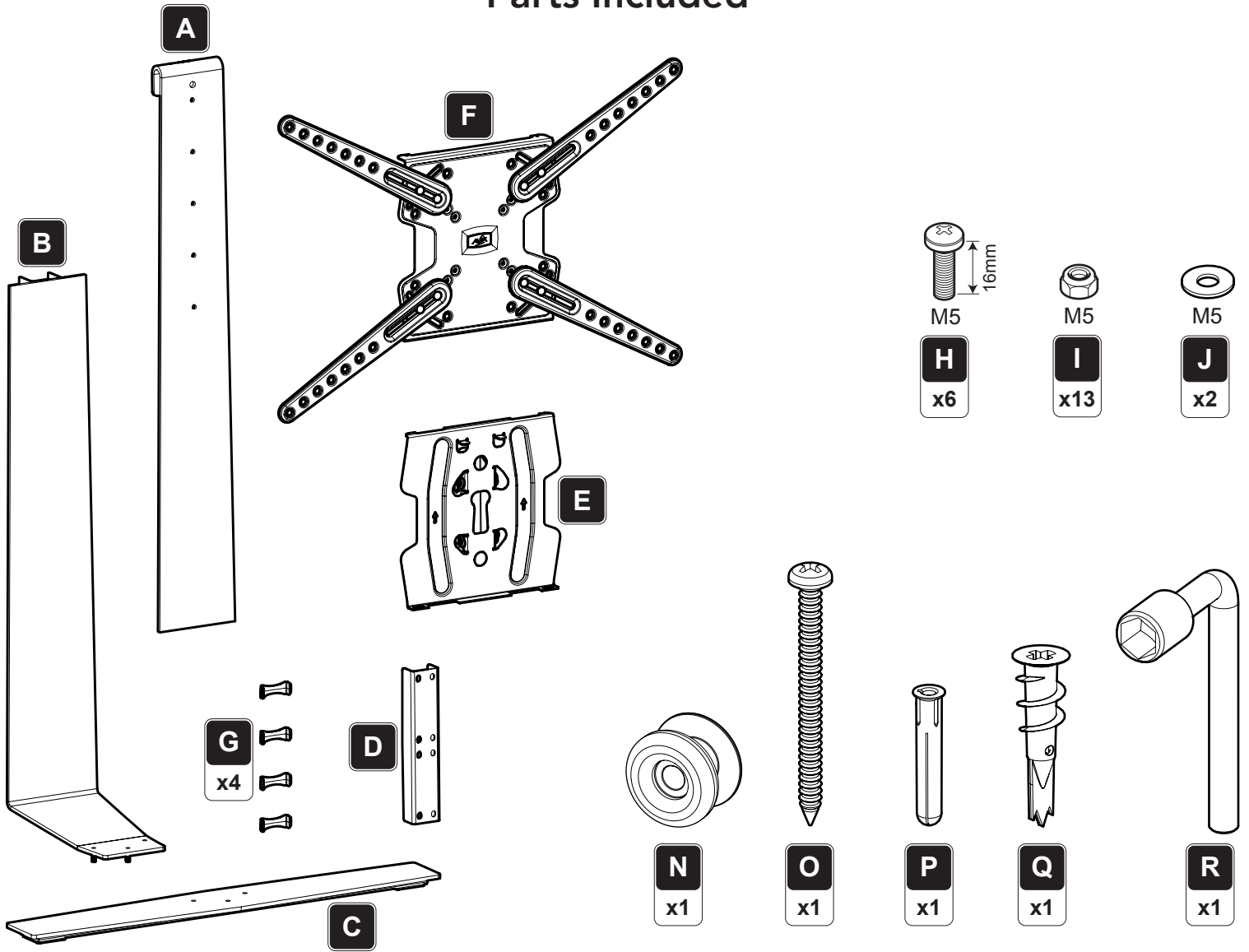

## TV Screws, Reducers and Spacers

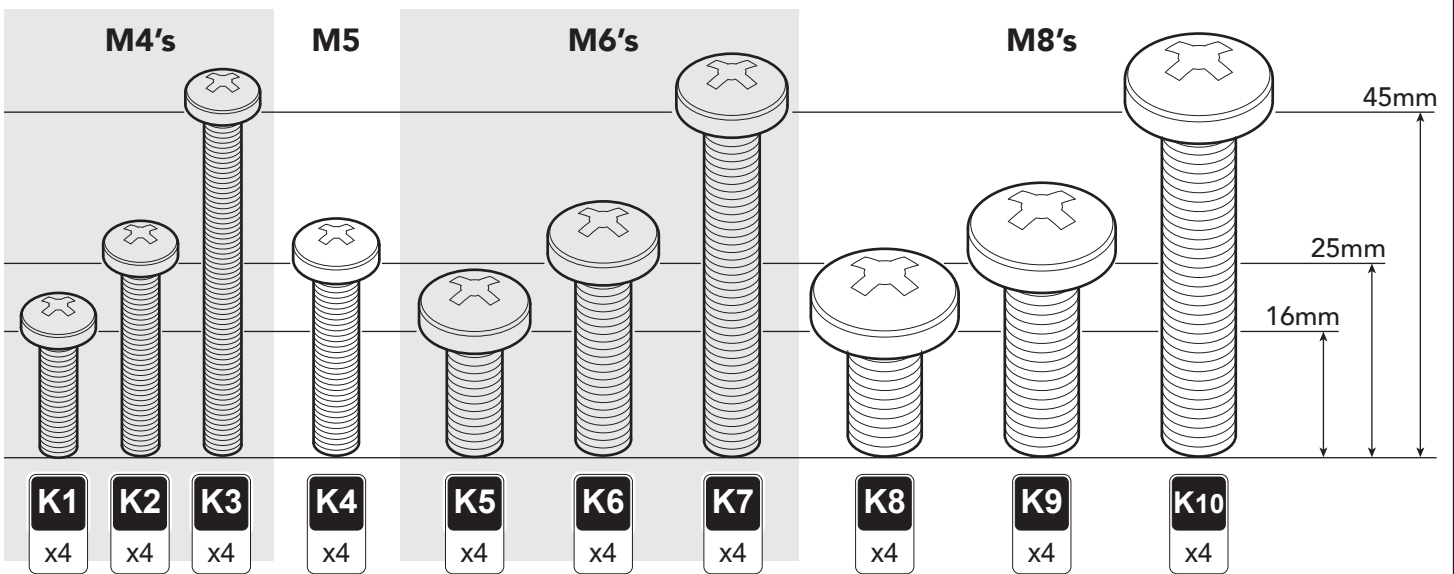

You will only need one set of TV Screws

## 3 Easy Steps

1

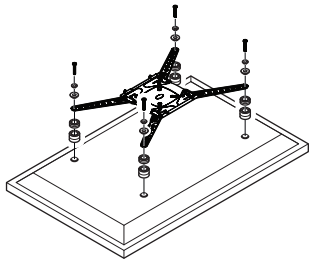

Attach the mount  
to your TV

2

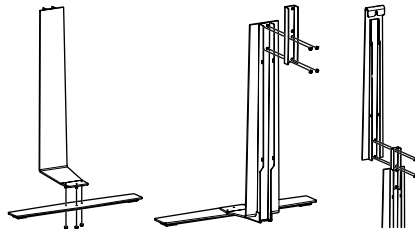

Build the column

3

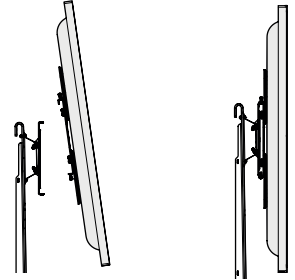

Hang and secure

1.1

Measure your VESA fixings and select TV Screws

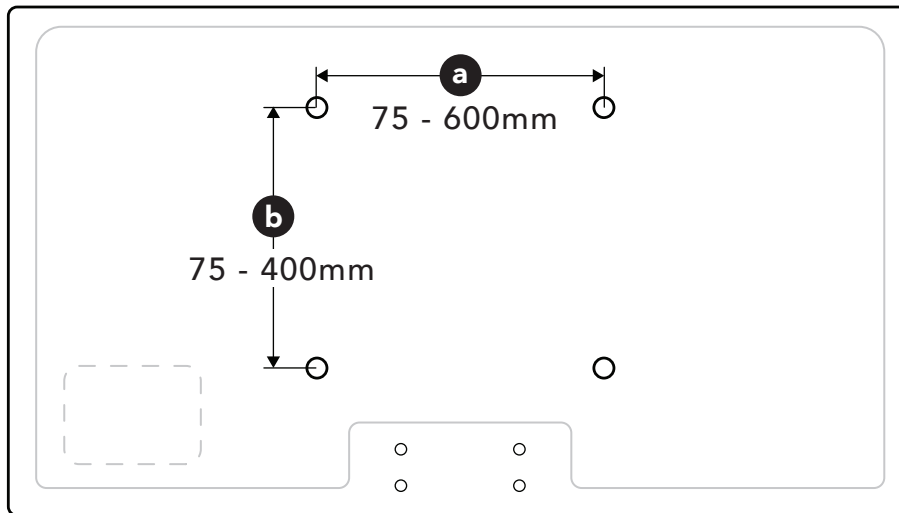

This product fits fixing holes up to 600 x 400mm (MAX).

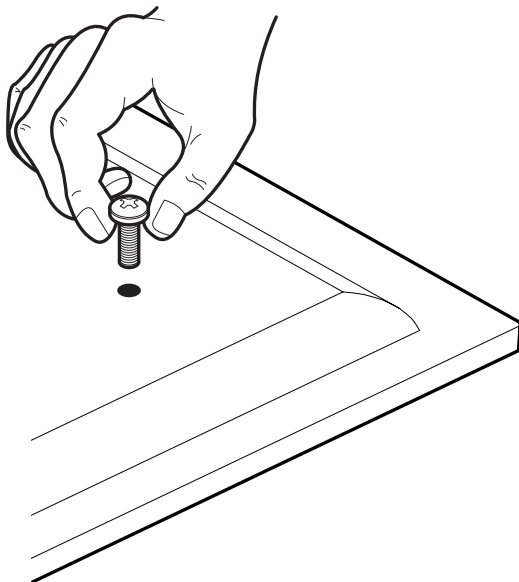

Determine which diameter TV Screws  
fit your TV and put them to one side.

**M4, M5, M6 or M8**

We will select the correct length later.

# 1.2

## Prepare the TV Mounting Plate

### Option 1

For TV fixing holes over 200 x 200mm.

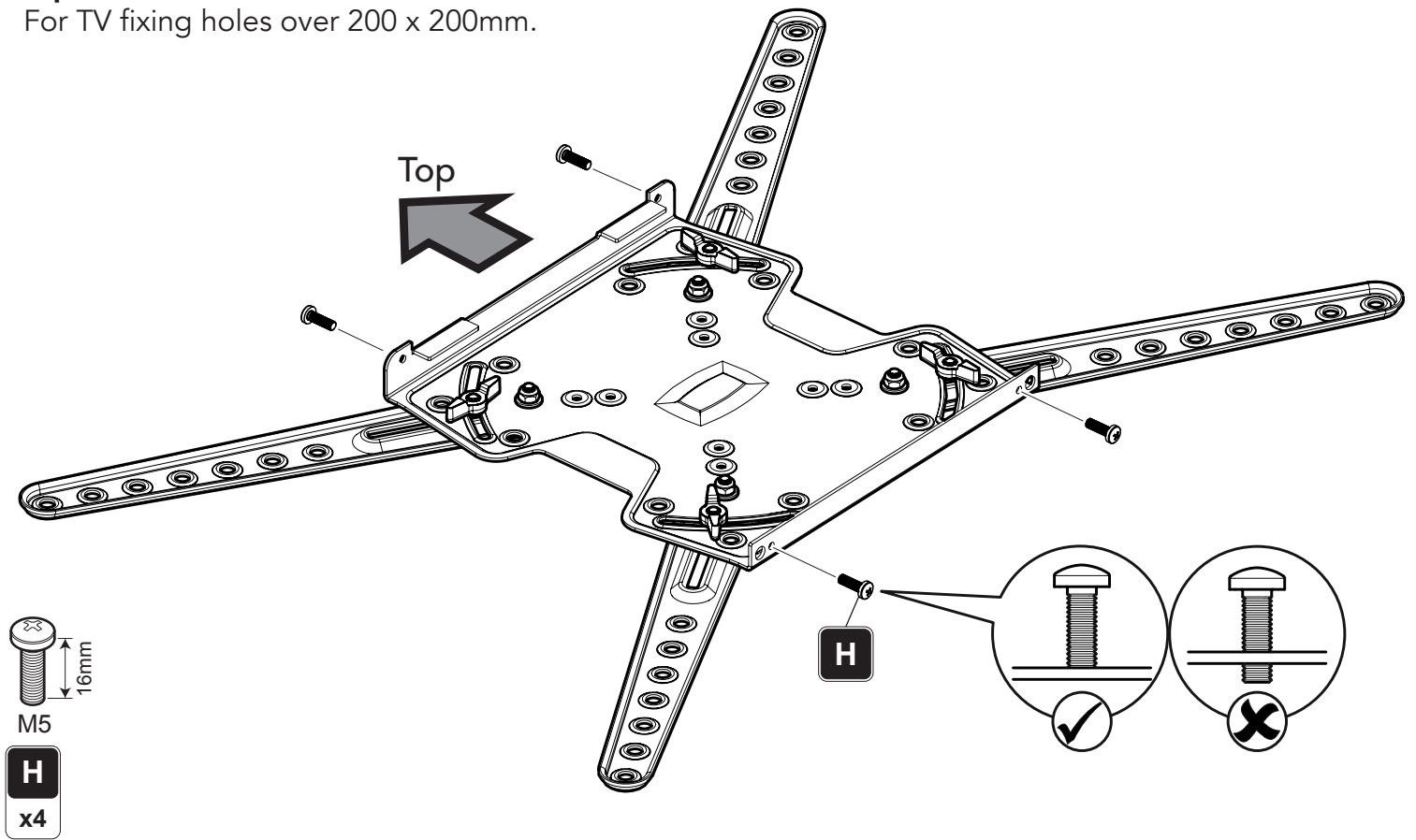

Loosen the Thumb Screws and adjust the VESA Adaptors to fit the holes on the back of your TV.

You can use any hole on the adaptors.

The TV Mounting Plate must be level and vertically centred on the back of your TV.

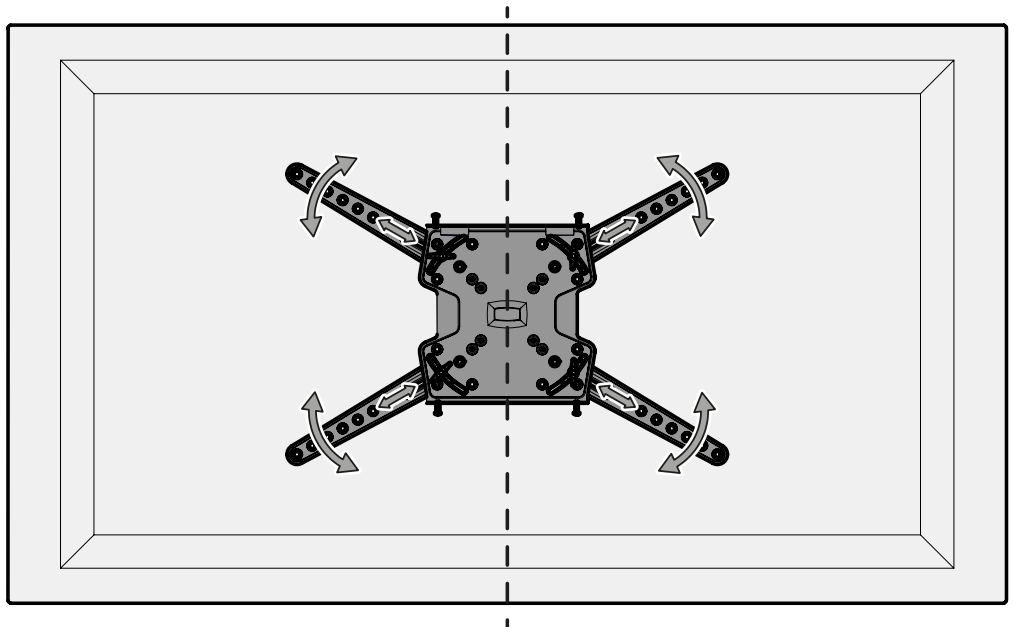
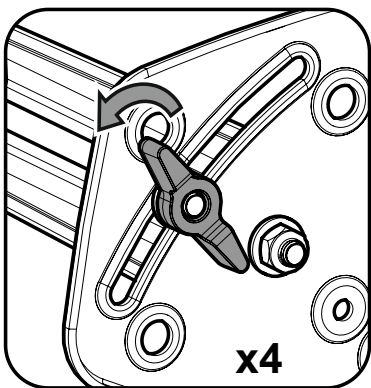

## Option 2

For TV Fixing Holes 200 x 200mm or less.

**i** If using Option 2 you need to remove the four VESA Adaptors. Keep the adaptors and fixings in a safe place in case they are needed in the future.

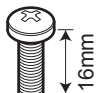
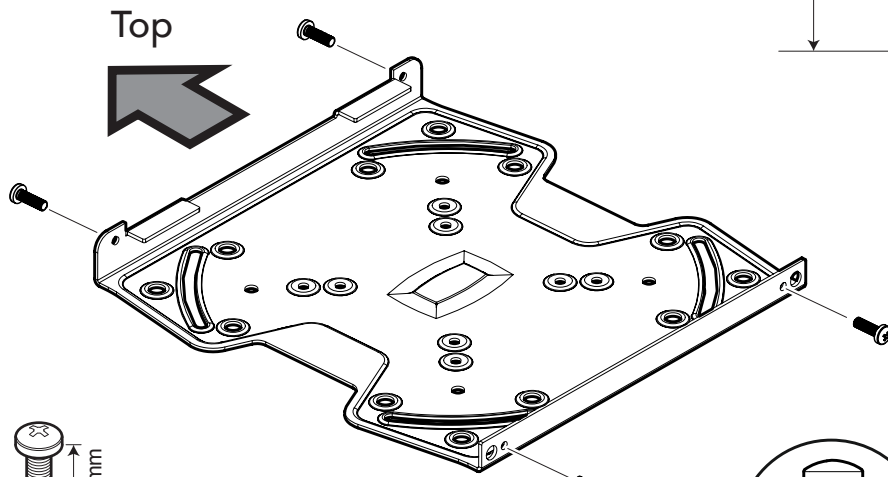
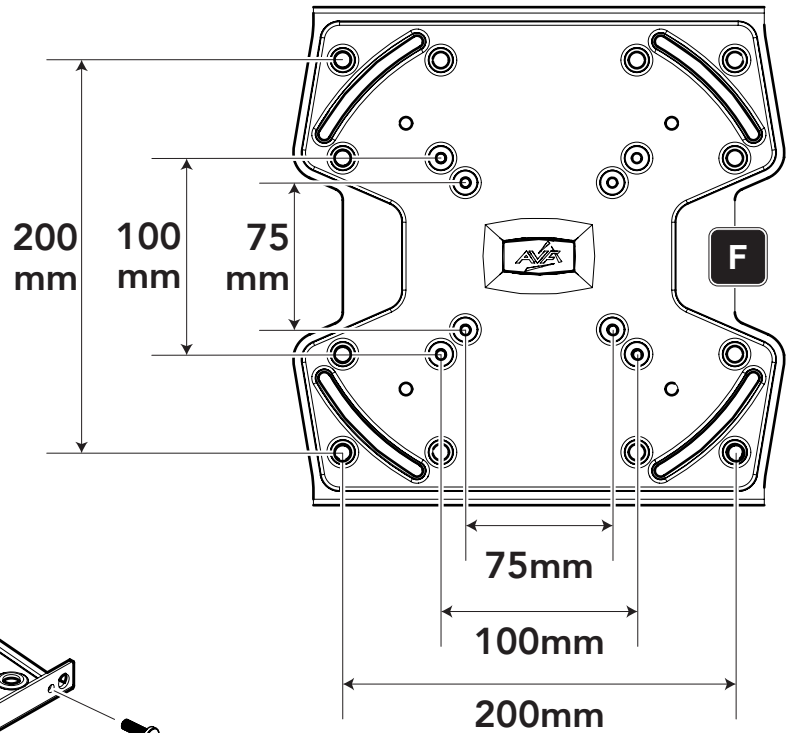
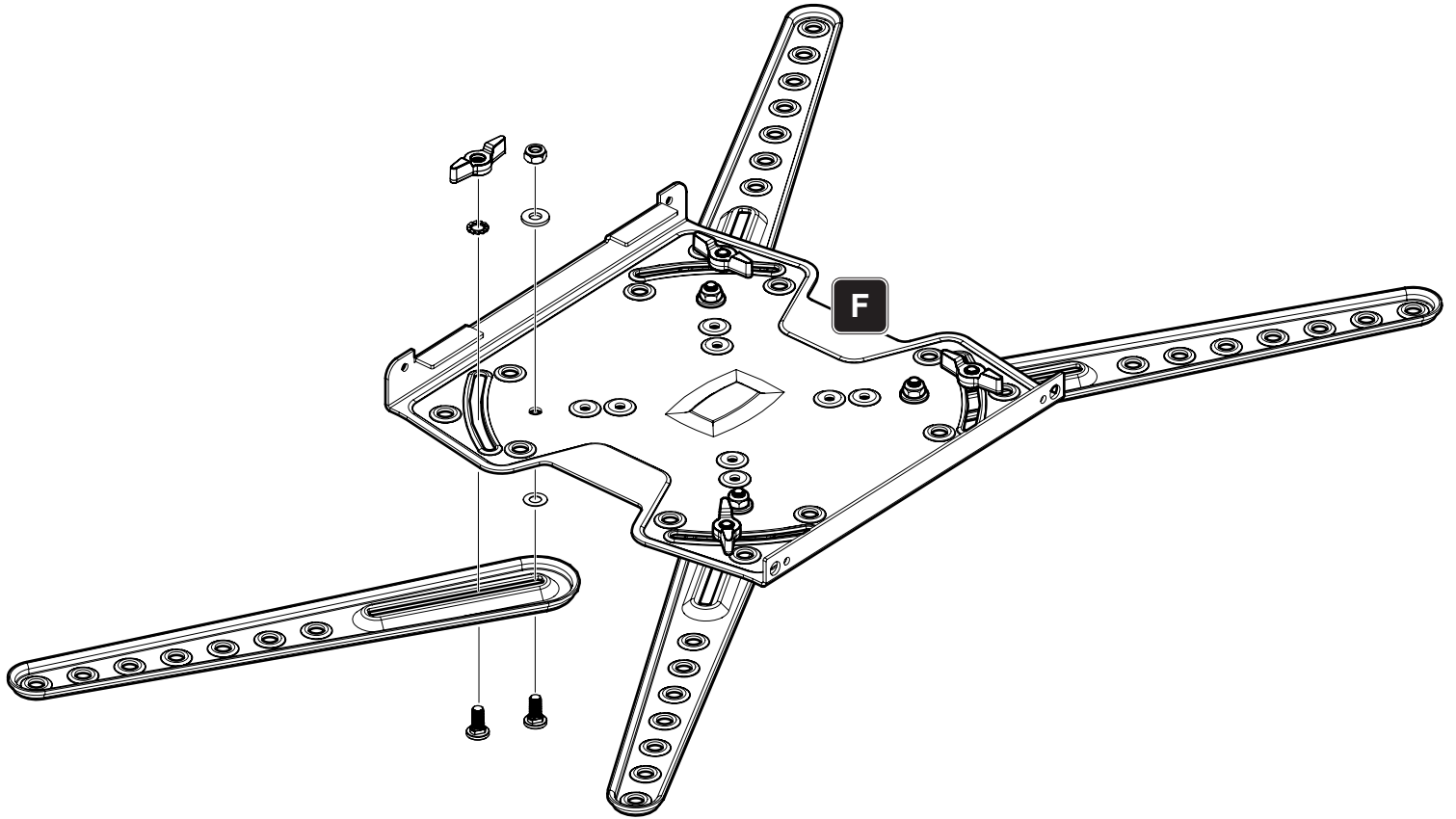

M5

**H**  
x4

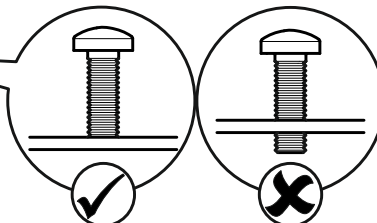

# 1.3 Fitting the TV Mounting Plate



After completing this step, you will have lots of TV screws left over. Keep them in a safe place in case you require them in future.

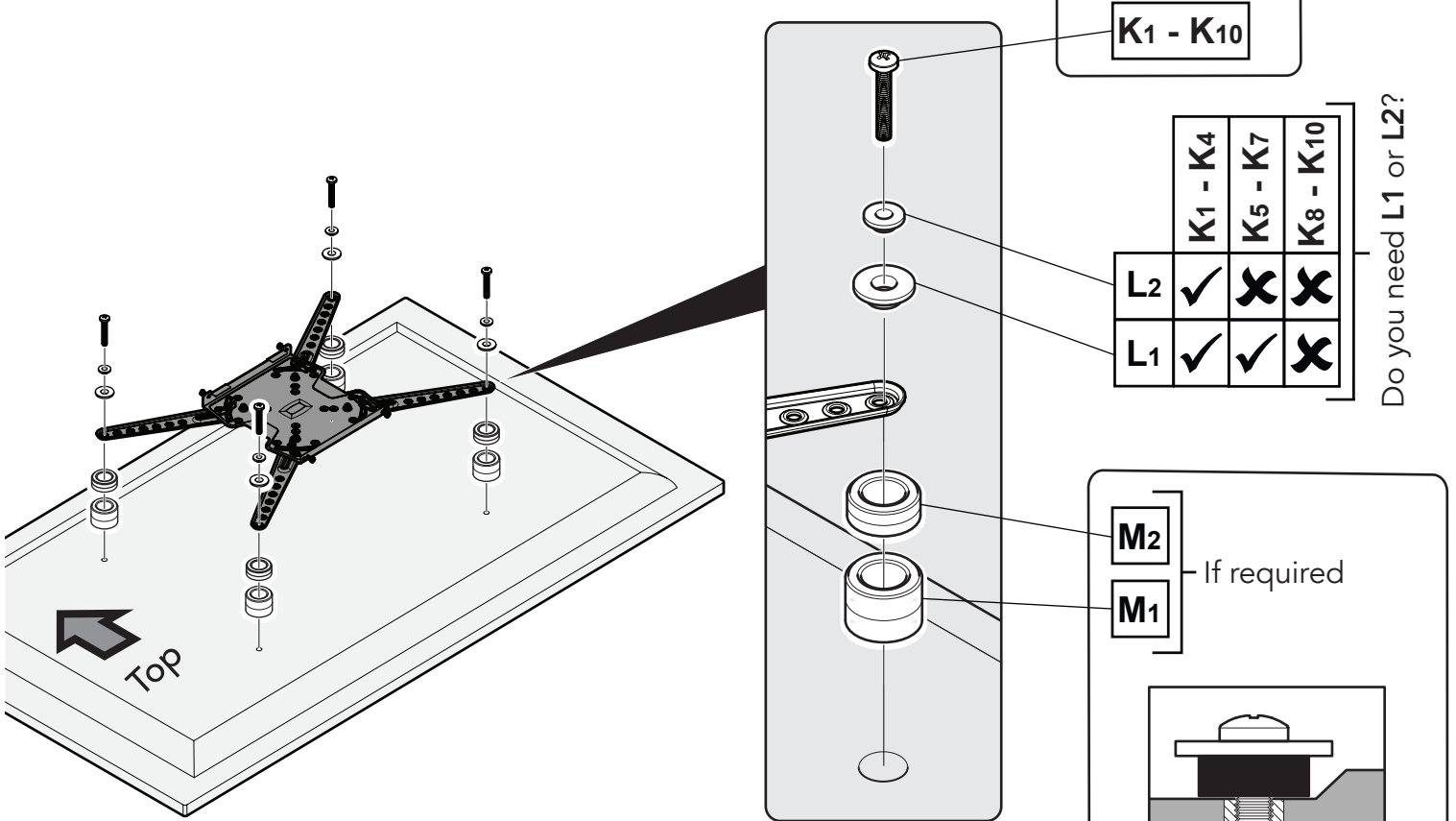
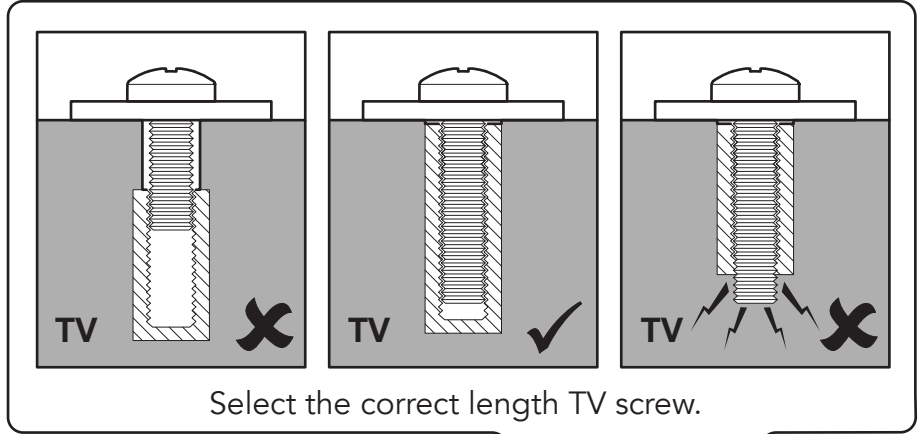

Make sure the TV Mounting Plate is still level and vertically centered on the back of your TV.

Tighten the Thumb Screws.

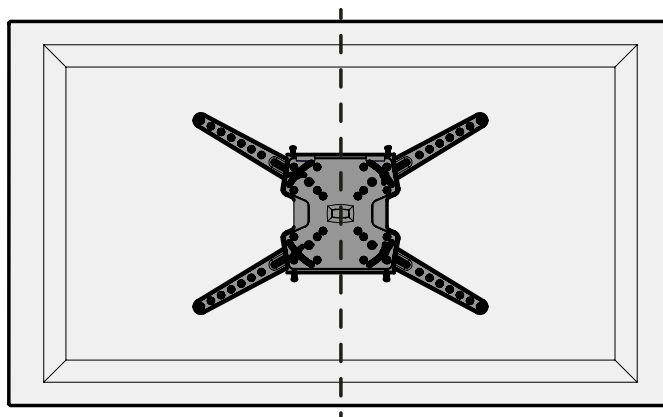
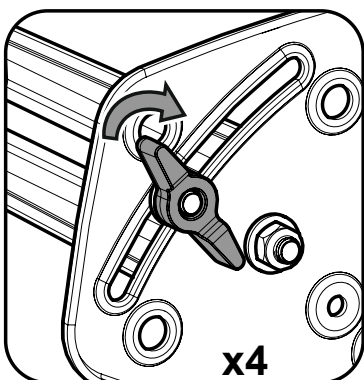

You may need to use Spacers **M1** or **M2** if the screws are too long or the back of your TV is not flat.

# 2.1

## Assemble the Column

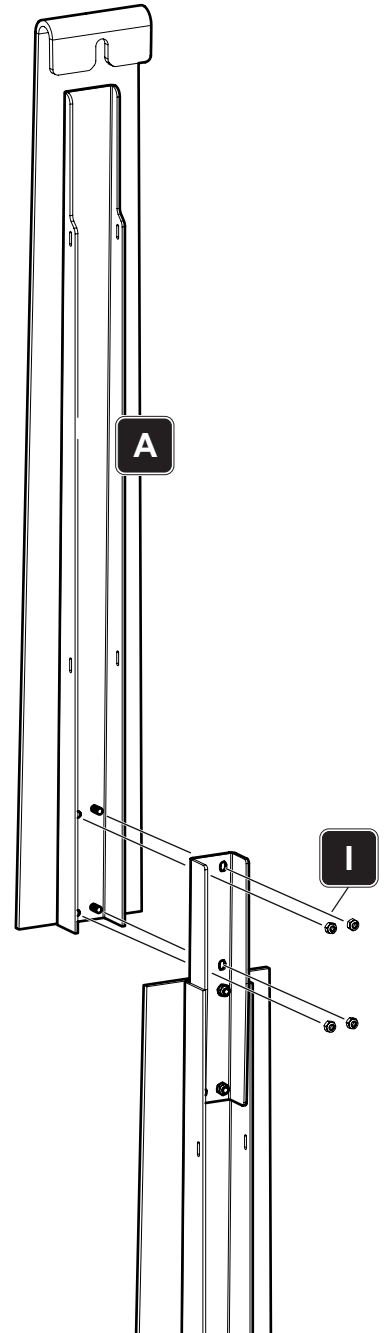
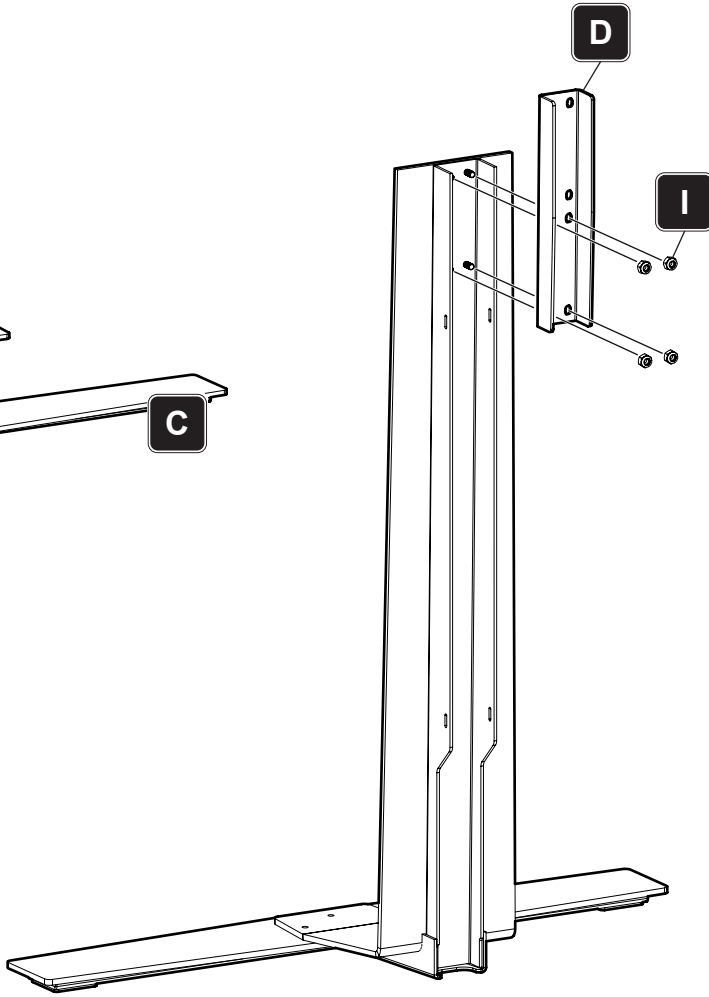
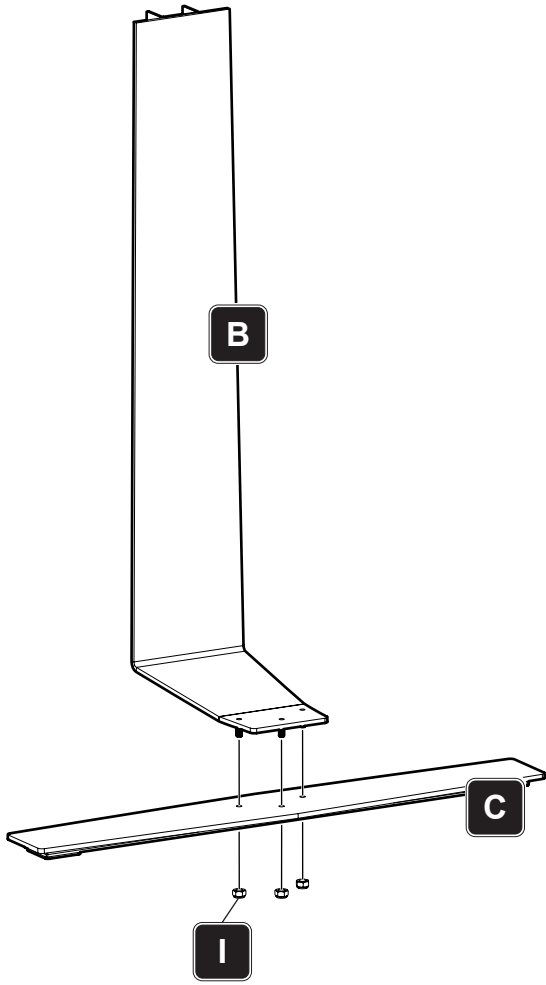

M5

I  
x11

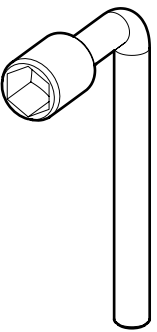

R  
x1

## 2.2

### Fitting the Anti-tip Wall Anchor (Optional)

**i** The anti-tip wall anchor is optional and provided for extra peace of mind.

Position your column against the wall where you want your TV. The rear edge of the column must be vertical and parallel to the wall. Mark the drill point through the top hole as shown.

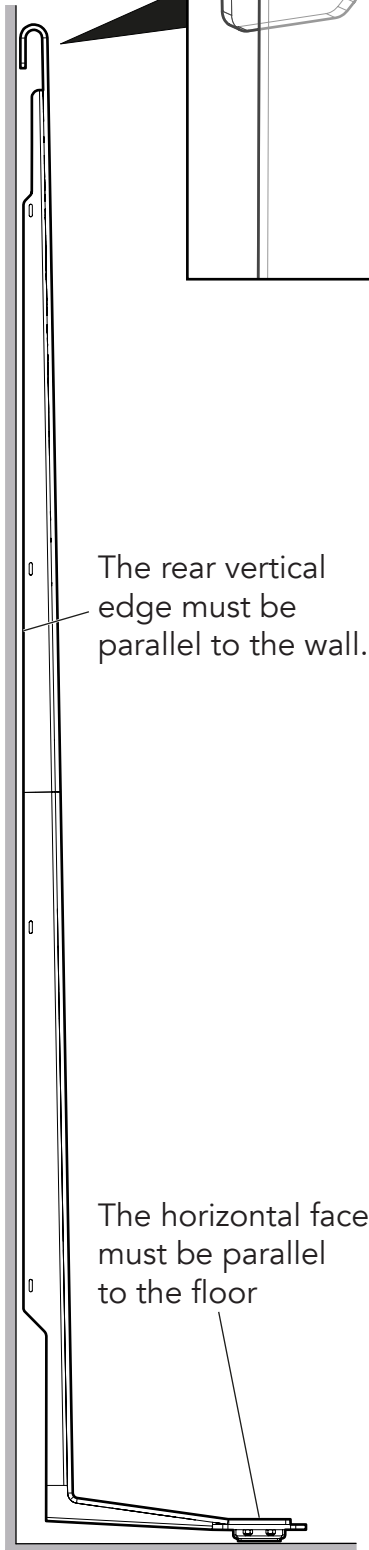
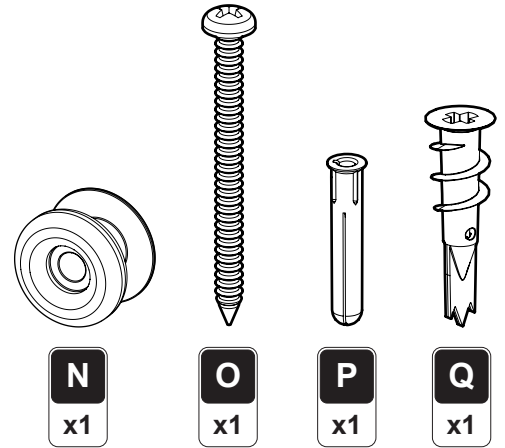
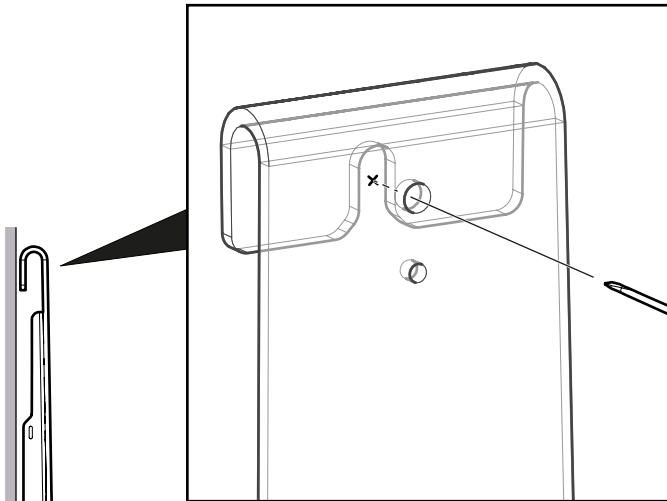

#### Wood Stud

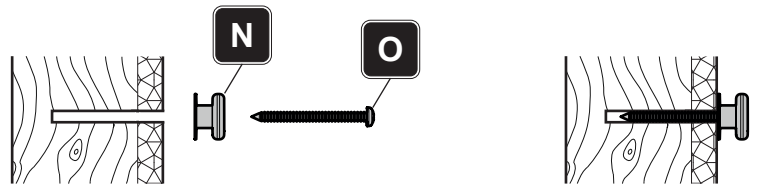
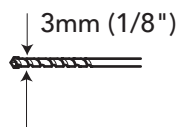

#### Solid Wall

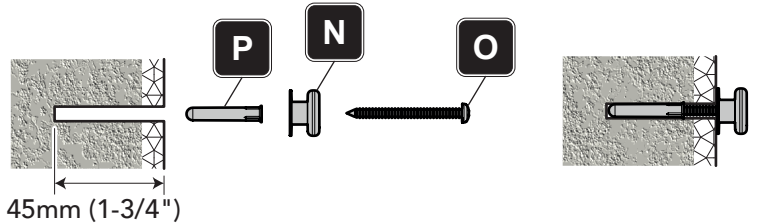
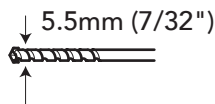

#### Plasterboard

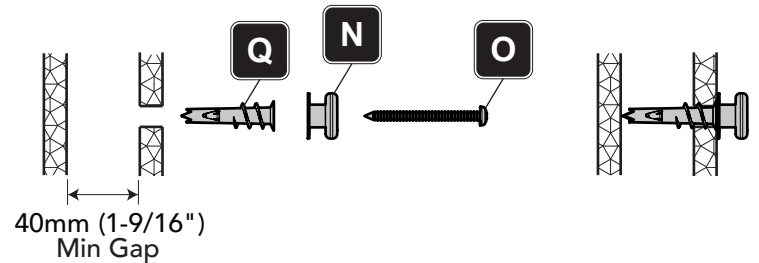
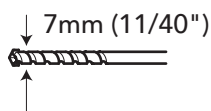

#### Dot and Dab

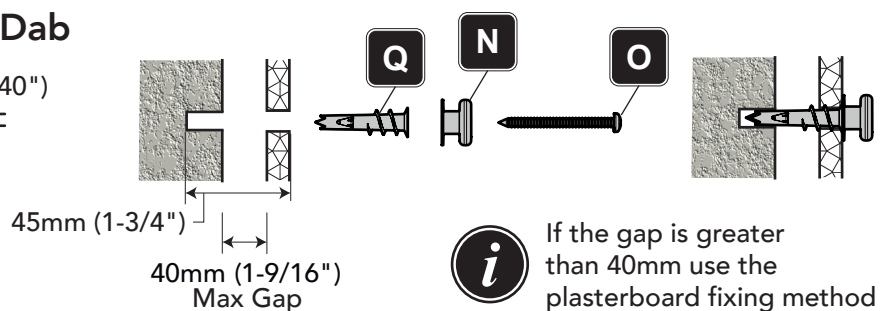
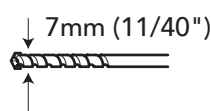

**i** If the gap is greater than 40mm use the plasterboard fixing method



## 2.3

### Fitting the TV Bracket



There are three height options for mounting the TV bracket. Choose the option that best allows you to mount the TV at your preferred height.

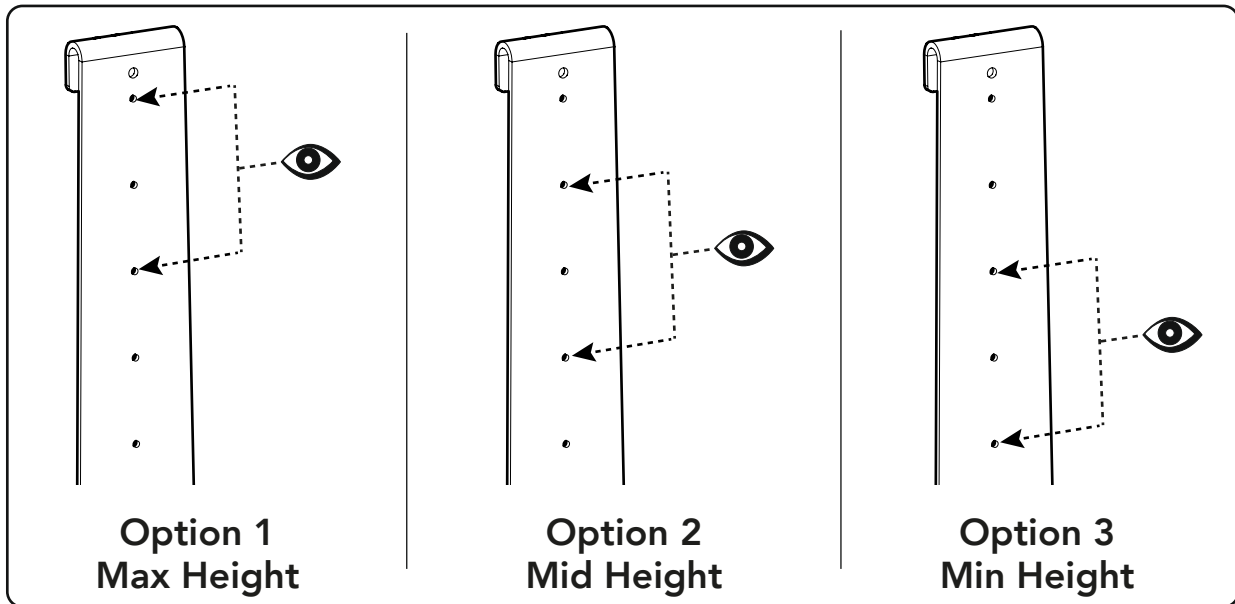

To work out the height of your TV from the floor (**B**) use the following calculations:

- Option 1** 1219mm (48") - **A** = **B**
- Option 2** 1151mm (45 5/16") - **A** = **B**
- Option 3** 1083mm (42 5/8") - **A** = **B**



Distance **A** is measured from the bottom of the TV Mounting Plate to the bottom of the TV.

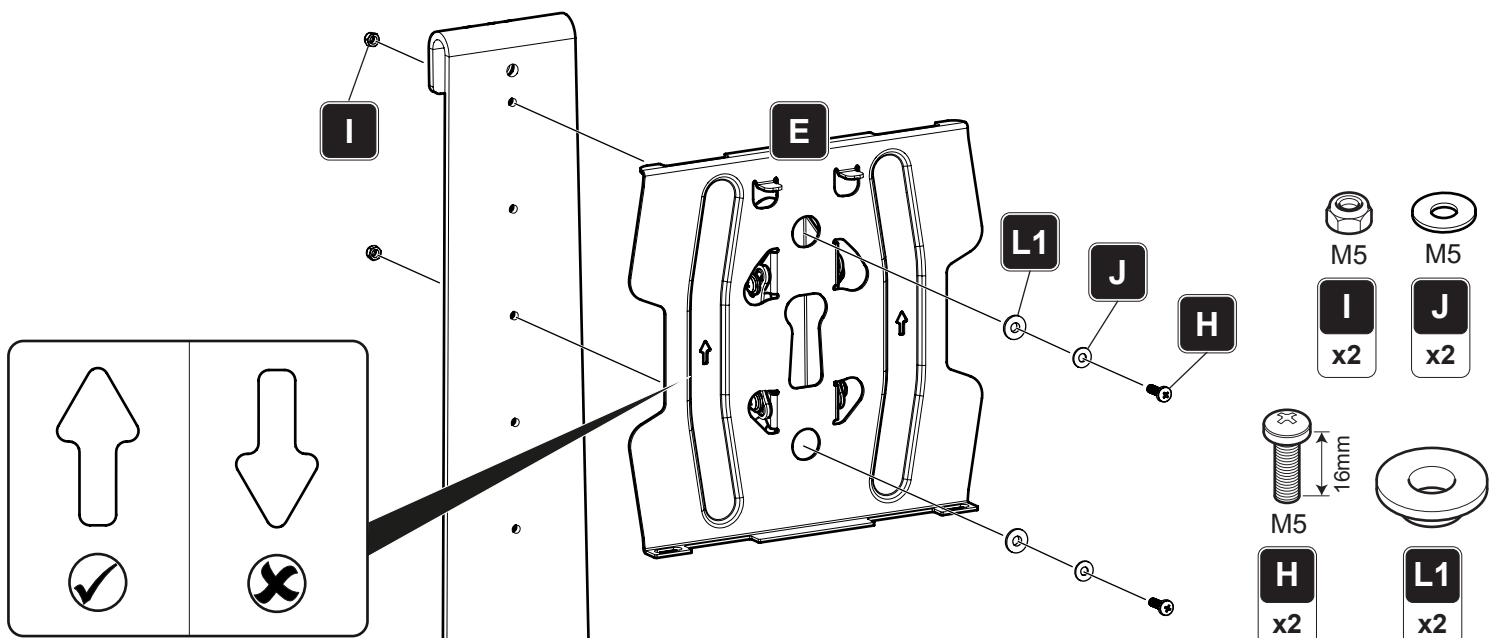
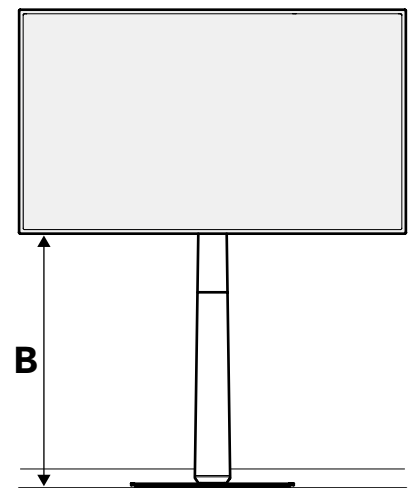
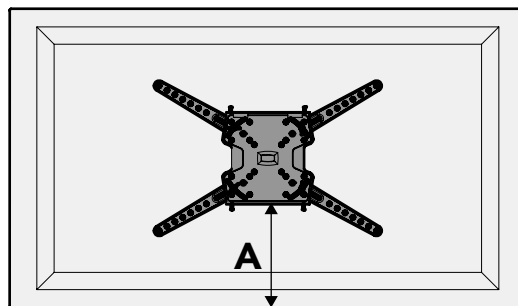

### 3.1 Cable Management

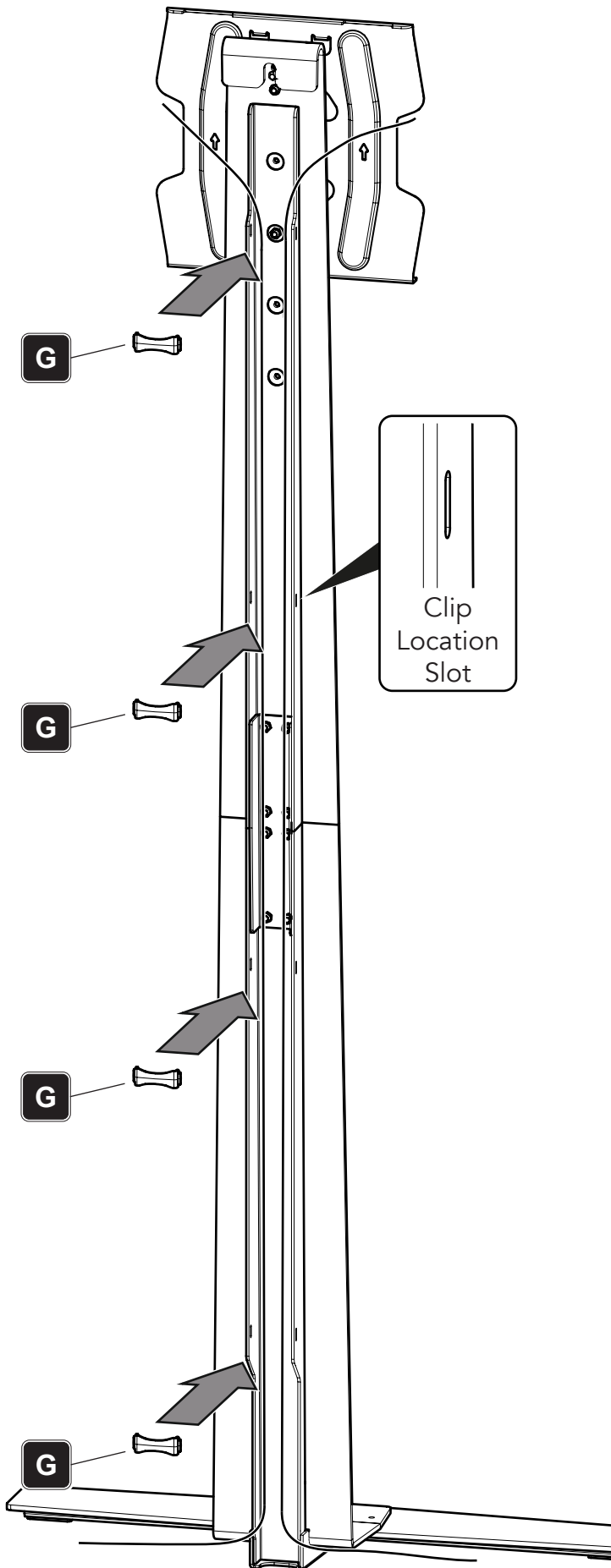

### 3.2a Position the Column

Position your column against the wall where you want your TV.

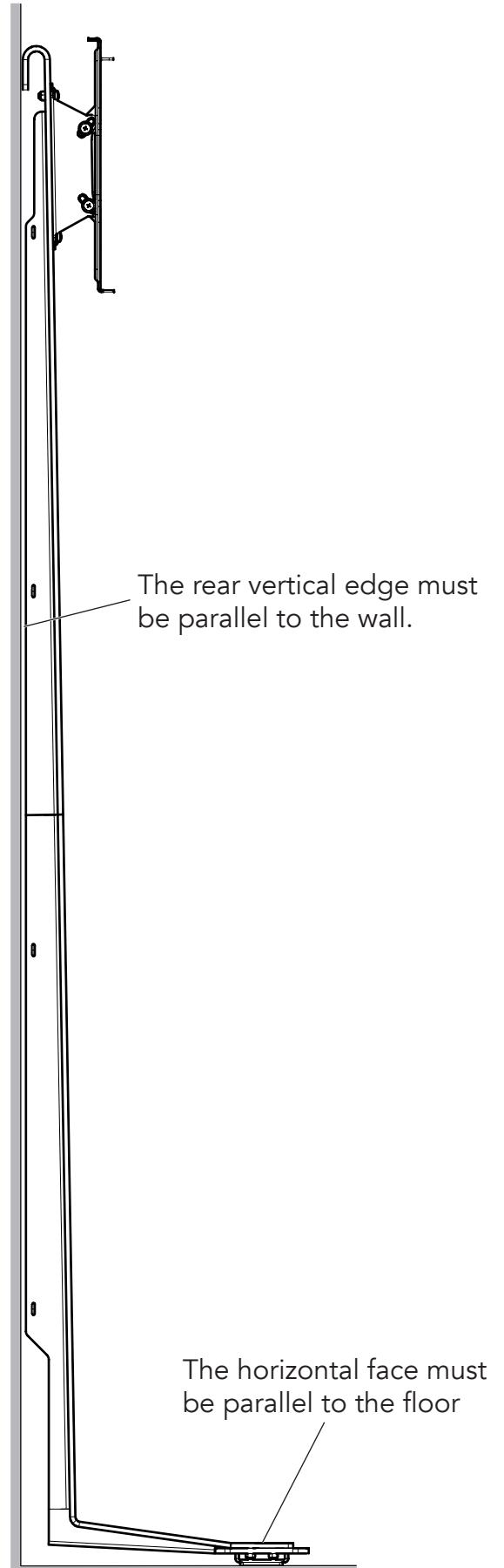

### 3.2b

## Attaching to Optional Anti-tip Wall Anchor



You only need to follow this step if you have decided to use the optional anti-tip wall anchor.

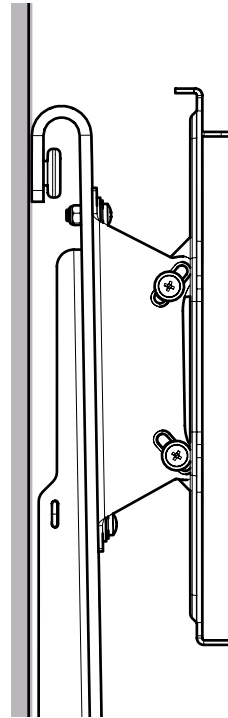
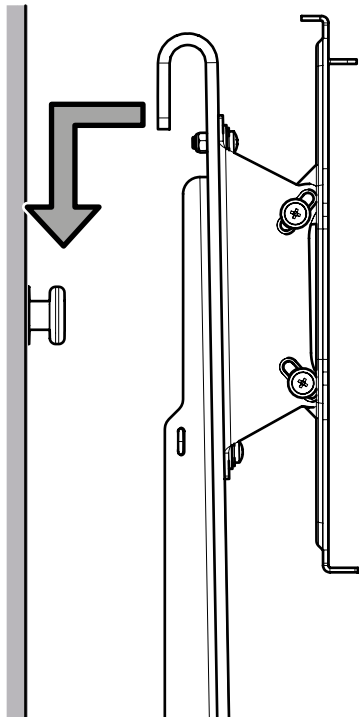

### 3.3

## Hanging the TV

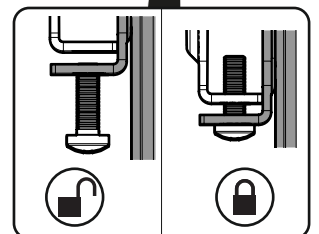
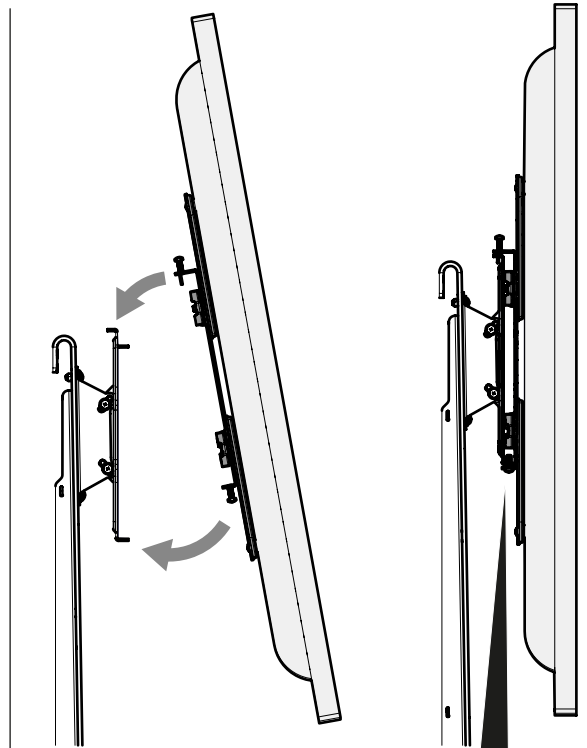
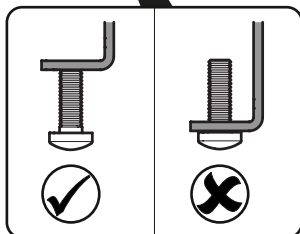
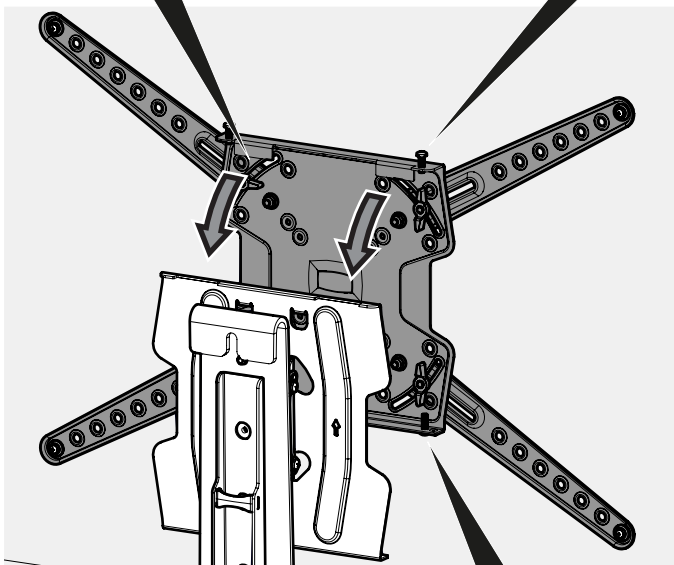
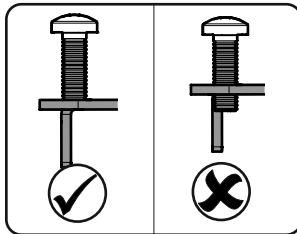
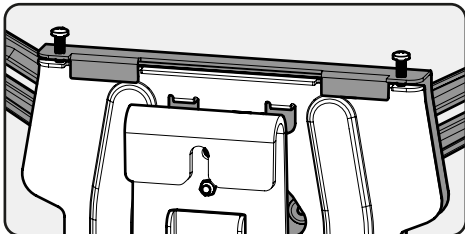

## TV Leveling (Optional)

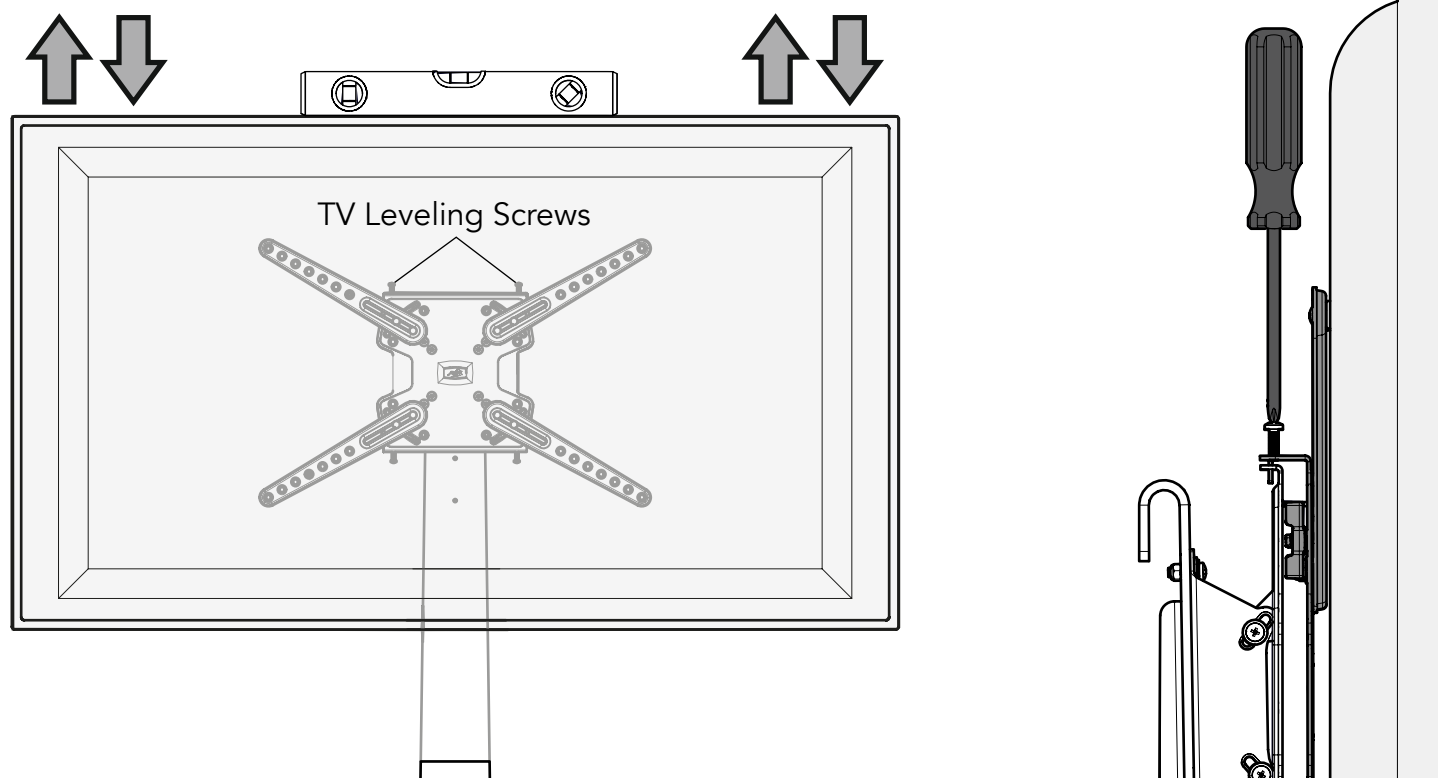

If your TV needs leveling, only adjust the TV Leveling Screw on the low side of the TV. For example, if the left hand side of your TV is low, adjust the left hand TV Leveling Screw only, until your TV is level.

## Tilt Adjustment (Optional)

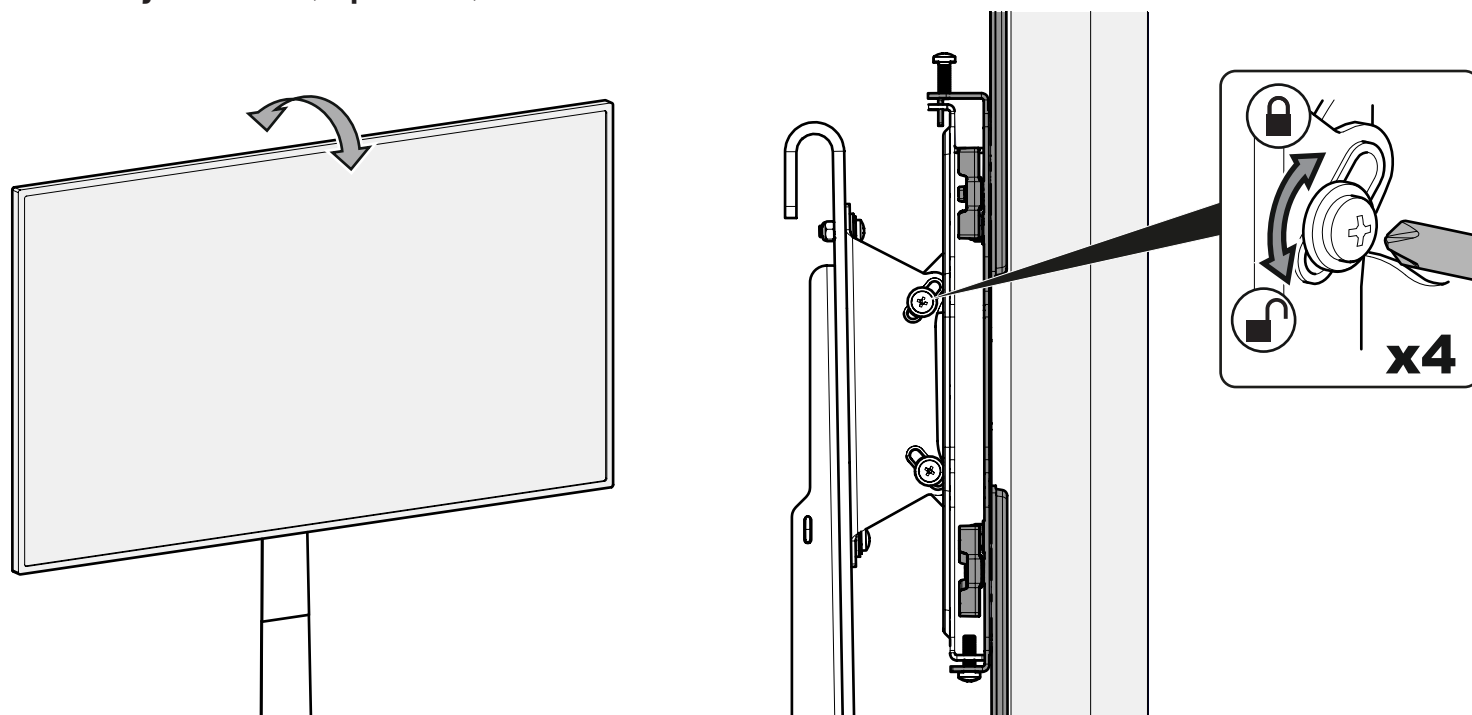

Adjust screws to achieve perfect tilt resistance if required. You can also lock the tilt if required.