

↓
Bereiten Sie die Verbindung und die Basis vor
Preparare il giunto e la base
Preparar o Encaixe e a Base

Optional
Opzionale
Opcional

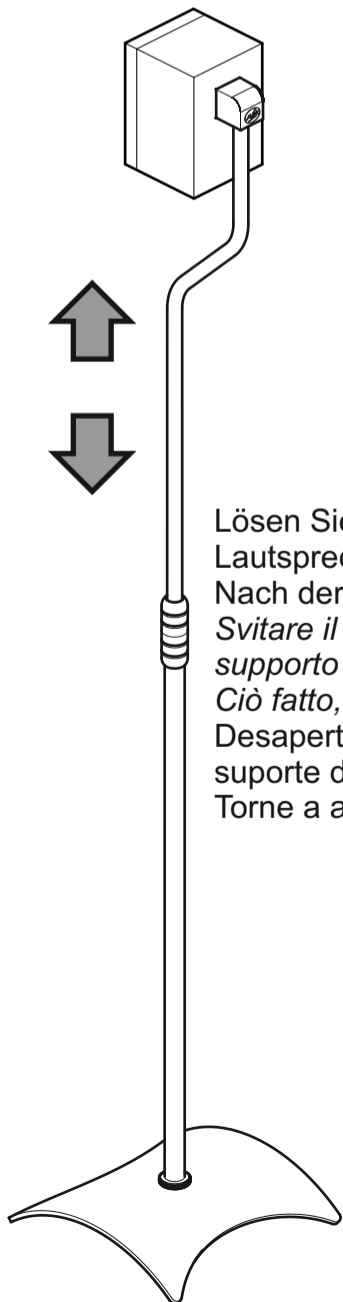

Lösen Sie das Gelenk, um die Höhe des Lautsprecherständers einzustellen.
Nach der Einstellung wieder festziehen.
Svitare il giunto per regolare l'altezza del supporto dell'altoparlante.
Ciò fatto, stringere di nuovo.
Desaperte o encaixe para ajustar a altura do suporte do altifalante.
Torne a apertar depois de ajustar.

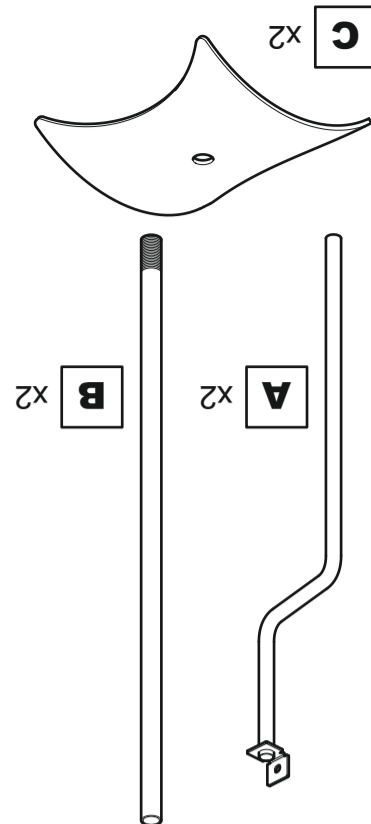
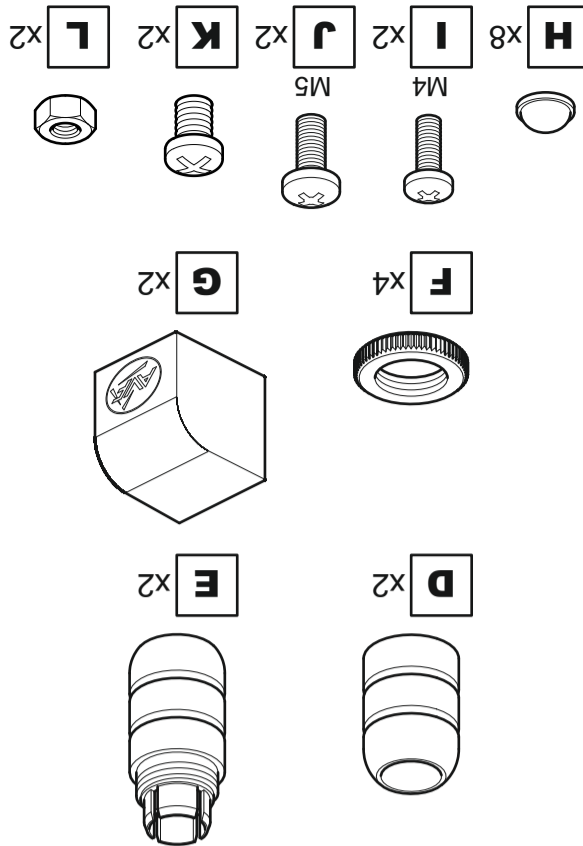

Verpackte Teile
Parti contenute nella confezione
Peças Embaladas

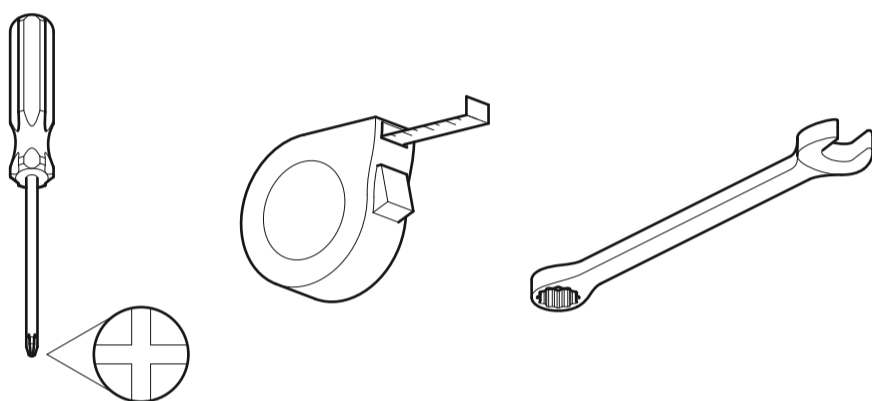

Empfohlene Tools
Attrezzi consigliati
Ferramentas Recomendadas

469252 rev00

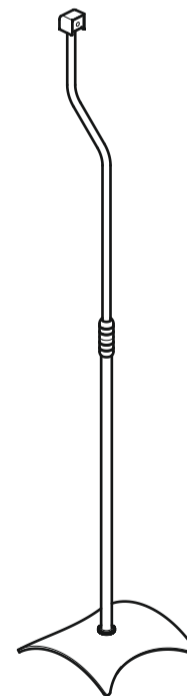

Lesen Sie die GESAMTEN Anweisungen durch, bevor Sie mit der Installation beginnen.
Sollten Sie Fragen zu diesem Produkt oder Probleme bei der Installation haben, wenden Sie sich bitte an Die Kundendienst Beratungsstelle, bevor Sie dieses Produkt an den Händler zurücksenden.



Prima di procedere con l'installazione, leggere TUTTE le istruzioni.
In caso di domande relative al prodotto o di problemi con l'installazione contattare telefonicamente il servizio clienti, prima di restituire l'articolo al negozio.



Leia TODAS as instruções antes de iniciar a instalação.
Se tiver algumas dúvidas sobre este produto ou problemas com a instalação, entre em contacto com a linha dos serviços de apoio ao cliente antes de devolver este produto à loja.

KUNDENSERVICE BERATUNGSSTELLE NUMMER:
NUMERO TELEFONICO DEL SERVIZIO CLIENTI:
NÚMERO DA LINHA DOS SERVIÇOS DE APOIO AO CLIENTE:
+44 (0) 333 320 0463 (UK)
1-800 667 0808 (USA)



2

Bereiten Sie die Lautsprecherständer vor
 Preparare i supporti per gli altoparlanti
 Prepare os Suportes do Altifalante

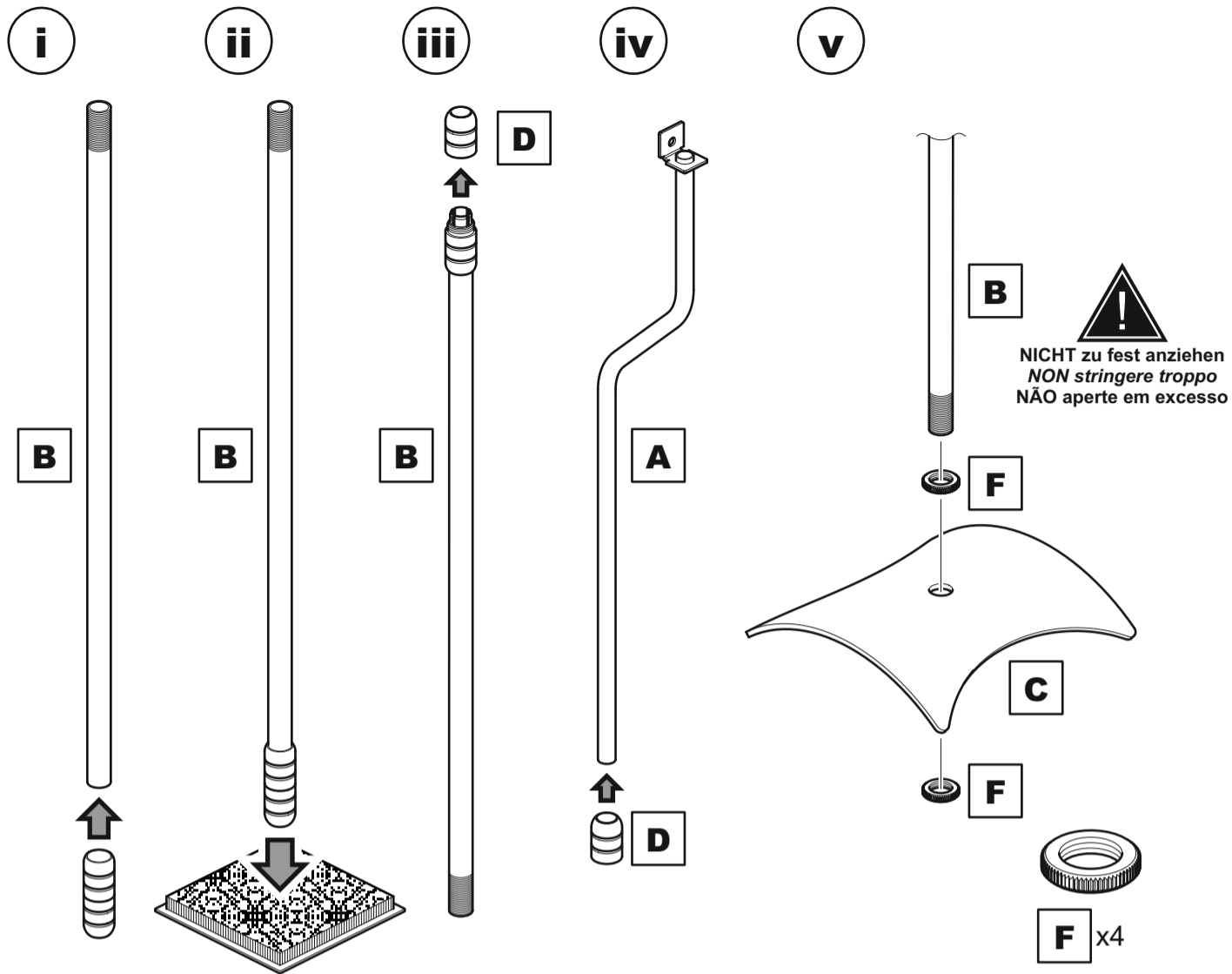

Setzen Sie die montierte Verbindung auf das Ende von Rohr **B** und klopfen Sie damit fest auf den Teppich, bis sie fest sitzt.
 Posizionare il giunto assemblato all'estremità del tubo **B** e battere con decisione sul tappeto fino al completo inserimento.
 Coloque o encaixe montado na extremidade do tubo **B** e bata firmemente no tapete até ficar inteiramente assente.

3

Schließen Sie die Röhren an
 Collegare i tubi
 Ligue os Tubos

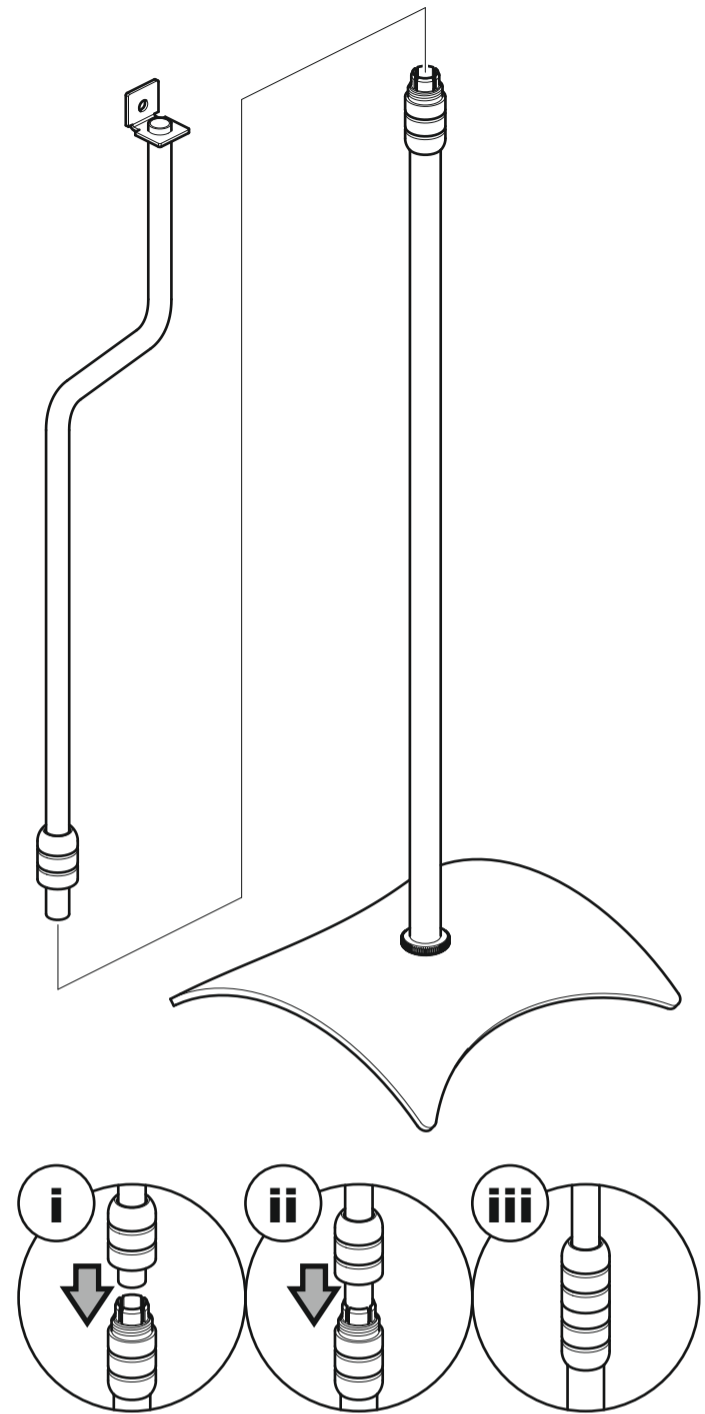
**4**

Kabelführung
 Passaggio dei cavi
 Gestão do cabo

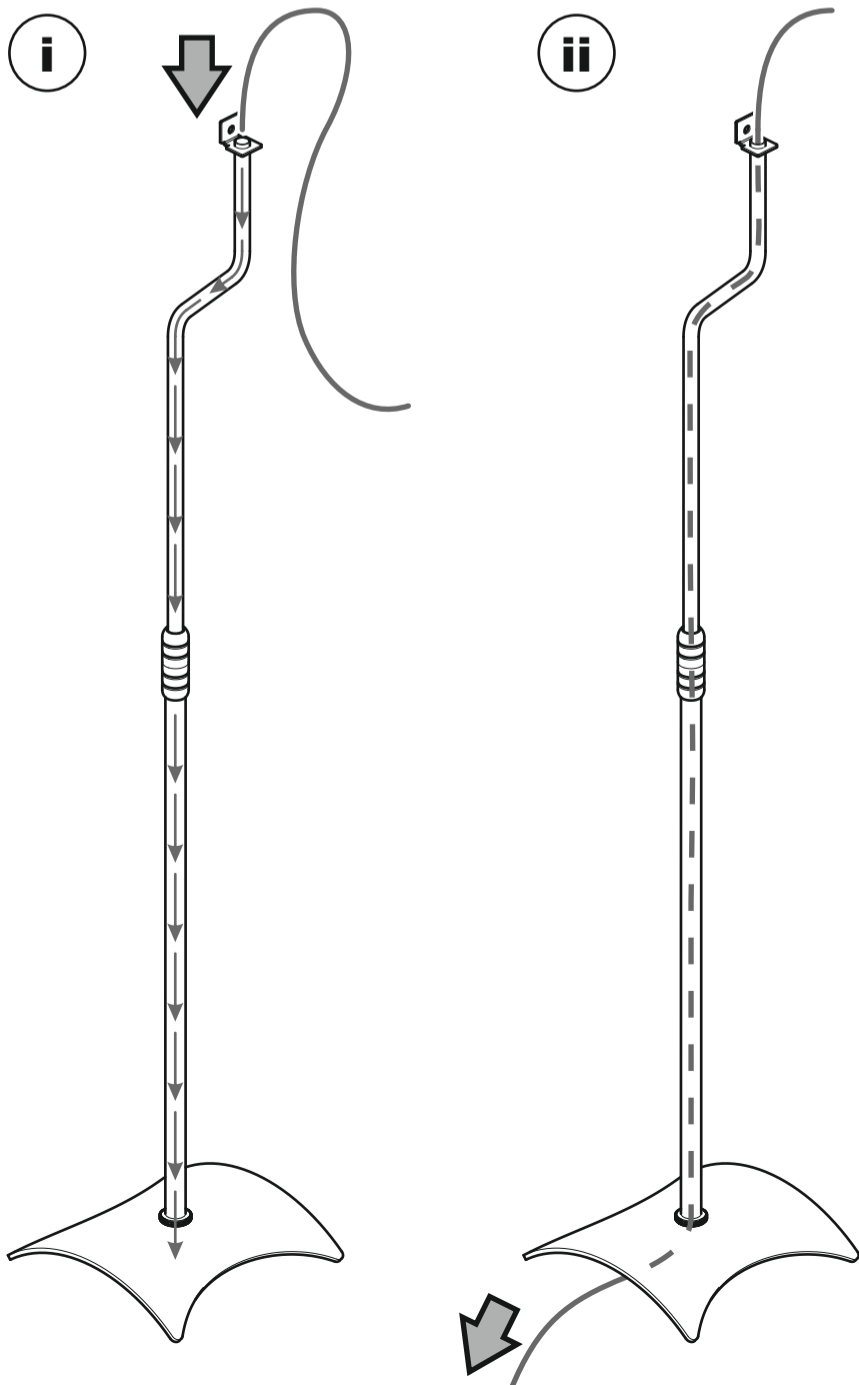
**5**

Passen Sie die Lautsprecher an
 Installare gli altoparlanti
 Encaixe os Altifalantes

Schlüssellochbefestigung
 Fissaggio della toppa
 Fixação do Buraco da Fechadura

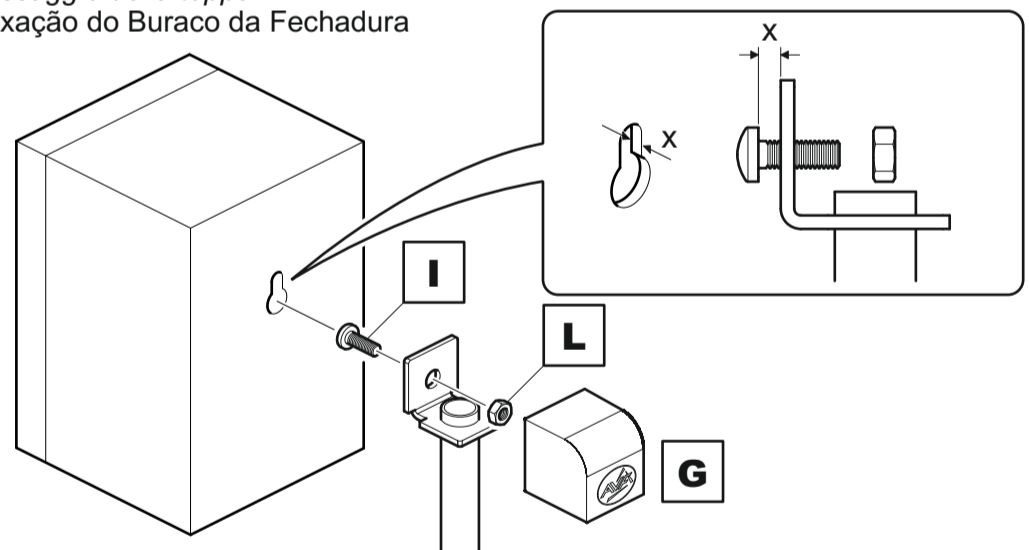

Gewindebohrung
 Fissaggio del foro filettato
 Fixação do Orifício Para Enroscar

