

[www.avfgroup.com](http://www.avfgroup.com)

468778rev00

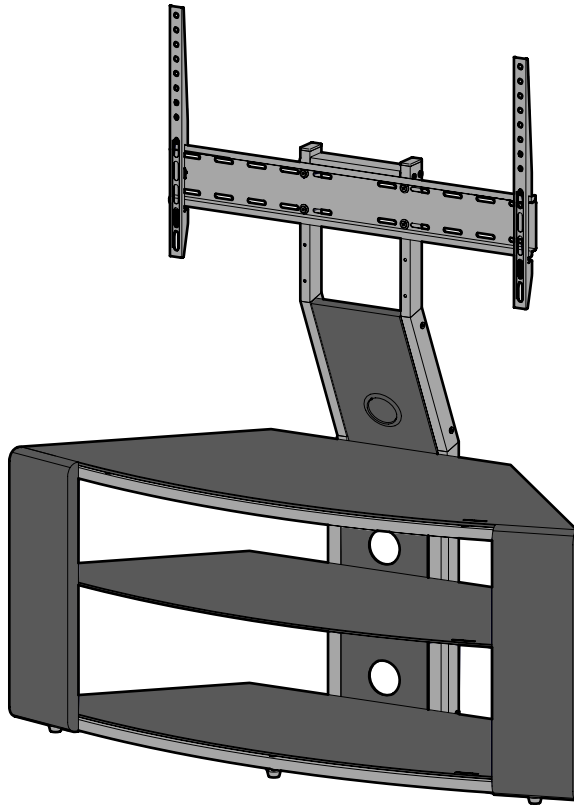

45 kg  
99 lbs

**STOP**

Read through **ALL** instructions before commencing installation.

If you have any questions about this product or issues with installation, contact the customer services help line before returning this product to the store.

**ARRETEZ  
-VOUS**

Lisez **TOUTES** les instructions avant de débiter l'installation.

Si vous avez des questions sur ce produit ou des problèmes d'installation, contactez l'assistance client avant de ramener le produit en magasin.

**ALTO**

Lea **TODAS** las instrucciones antes de comenzar la instalación.

Si tiene alguna pregunta sobre el producto o problemas con la instalación, llame a la línea de servicio al consumidor antes de devolverlo.

CUSTOMER SERVICES HELP LINE NUMBER: **+44 (0) 333 320 0463 (UK)**

NUMÉRO DE L'ASSISTANCE CLIENT:

NUMERO DE SERVICIO DE ATENCION AL CLIENTE: **1-800 667 0808 (USA)**

**IMPORTANT INFORMATION!**

We advise that before starting the assembly of this product that you familiarise yourself with the instructions and the parts list in this leaflet.

**INFORMATIONS IMPORTANTES!**

Nous vous recommandons de vous familiariser avec ces instructions et la liste des pièces détachées contenues dans ce document avant de commencer l'assemblage de ce produit.

**INFORMACIÓN IMPORTANTE!**

Le recomendamos que antes de comenzar el ensamblaje de este producto se familiarize con las instrucciones y la lista de partes en esta hoja informativa.

**DO NOT'S**

Do not over tighten any part of this assembly.

Do not place hot or cold objects on to or close next to any glass surface unless the object is sufficiently insulated to prevent contact.

Do not strike the glass with hard or pointed items.

Do not sit or stand upon horizontal glass surfaces.

Do not use washing powders or other substances containing abrasives when cleaning the glass.

**À ne pas faire**

Ne serrez pas trop fort aucun des éléments de cet assemblage.

Ne placez aucun objet froid ou chaud sur ou à proximité de toute surface en verre à moins que celui-ci ne présente une isolation suffisante pour empêcher tout contact.

Ne frappez pas les surfaces en verre avec des objets lourds ou pointus.

Ne vous asseyez ni ne montez pas sur les surfaces horizontales en verre.

N'utilisez pas de poudre à récurer ou toute autre substance abrasive lorsque vous nettoierez les surfaces en verre car cela risquerait de provoquer des rayures.

**NO haga**

No apriete demasiado ninguna de las piezas de este soporte.

No coloque objetos calientes o fríos en o cerca de cualquier superficie de vidrio, a menos que el objeto esté aislado para prevenir contacto directo.

No golpee el vidrio con artículos fuertes o punzantes.

No se siente o se pare en superficies de vidrio.

No use detergentes para lavar u otras sustancias que contengan abrasivos cuando esté limpiando el vidrio ya que estas pueden rayarlo.

**DO'S**

Do use a damp cloth with diluted washing up liquid for cleaning the glass surfaces.

Check all nuts and bolts from time to time.

**À faire**

Utilisez un chiffon humide imprégné de liquide vaisselle dilué pour le nettoyage des surfaces en verre. Vérifiez tous les écrous et les boulons de temps à autre.

**si haga**

Use un trapo suave con líquido diluido en agua para limpiar las superficies de vidrio.

Compruebe todos los tornillos y tuercas de vez en cuando.

**Maximum TV weight and shelf capacities**

**Poids maximal du téléviseur et capacité de charge de l'étagère**

**Máximo peso y capacidad de estante de TV**

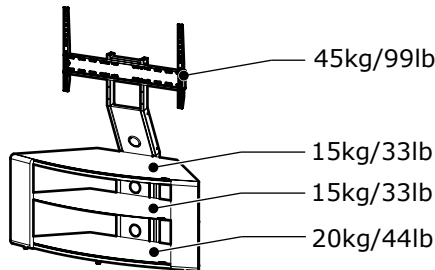

**WARNING:** Wherever possible distribute weight evenly.

**AVERTISSEMENT:** Répartissez le poids de manière uniforme lorsque cela est possible.

**ADVERTENCIA:** En la medida de lo posible distribuya el peso uniformemente.

boxed parts  
 pièces emballées  
 piezas en la caja

Tools recommended  
 outils recommandés  
 herramientas recomendadas

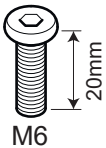
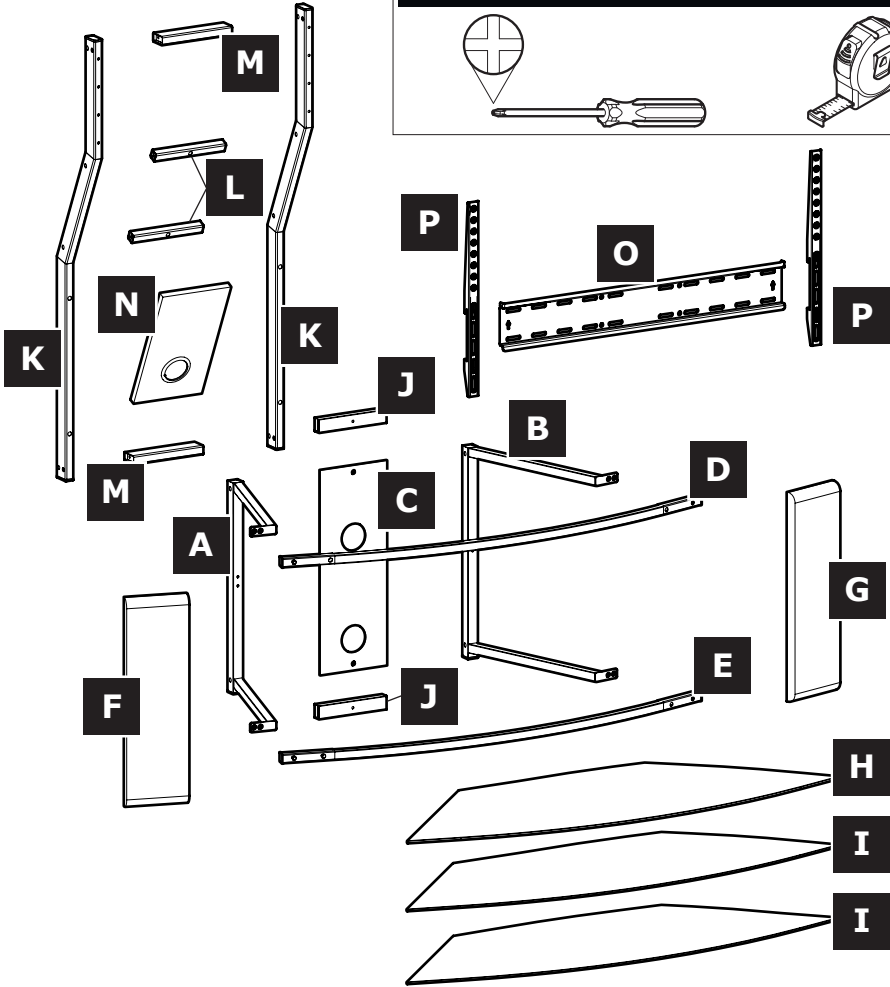

M6

**Q**  
x14

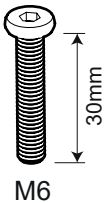

M6

**R**  
x10

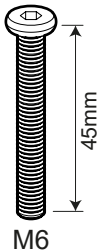

M6

**S**  
x16



**T**  
x13



**U**  
x4

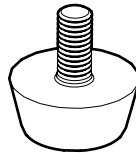

**V**  
x3



**W**  
x8



4mm

**X**  
x1

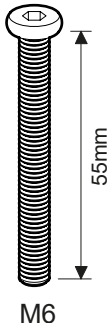

M6

**Y**  
x4

**TV screws, Reducers and spacers**  
**vis TV, réducteurs et séparateurs**  
**TORNILLOS, REDUCTORES Y ESPACIADORES PARA TV**



**SP1**  
x4



**SP2**  
x4



**RE1**  
x4



**RE2**  
x4

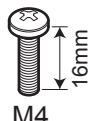

**M4**  
x4

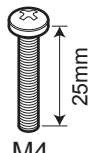

**M4**  
x4

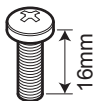

**M5**  
**TV3**  
x4

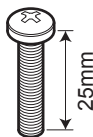

**M5**  
**TV4**  
x4

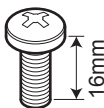

**M6**  
**TV5**  
x4

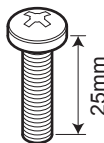

**M6**  
**TV6**  
x4

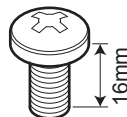

**M8**  
**TV7**  
x4

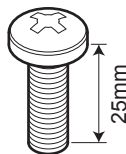

**M8**  
**TV8**  
x4

**1**

**Measure the TV fixing holes Width and Height**  
**Mesurer la profondeur et la taille des trous de fixation**  
**Mida los orificios de su TV, lo ancho y lo alto**

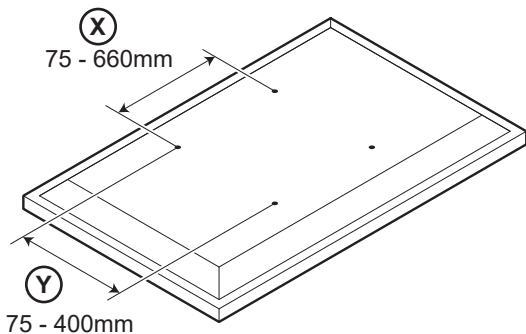

If width (X) is greater than 660mm or height (Y) greater than 400mm STOP installation now and contact the customer help line

*Si la largeur (X) est plus large que 660mm et la hauteur (Y) plus grande que 400mm, ARRÊTEZ l'installation immédiatement et contactez l'assistance client*

Si la anchura (X) es mayor que 660mm o la altura de (Y) es mayor que 400mm DETENGA la instalación inmediatamente y póngase en contacto con la línea de ayuda al cliente

<b>M4 =</b>	<b>TV1-2</b>
<b>M5 =</b>	<b>TV3-4</b>
<b>M6 =</b>	<b>TV5-6</b>
<b>M8 =</b>	<b>TV7-8</b>

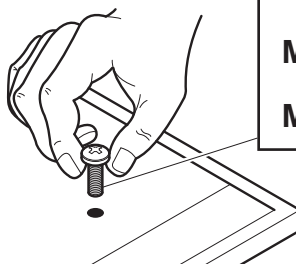

You are provided with 4 diameters of TV fixing screws, **M4**, **M5**, **M6** and **M8**. Determine the screw diameter that fits and remember for step 14.

*4 diamètres de vis TV vous sont fournis, **M4**, **M5**, **M6** et **M8**. Déterminez le diamètre de la vis qui convient et mémorisez- le pour l'étape 14.*

Se le proporciona con 4 diámetros de tornillos de fijación para su TV: **M4**, **M5**, **M6** y **M8**. Determine el diámetro del tornillo que le quede a su TV y recuérdelo para el paso 14.

2

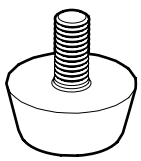
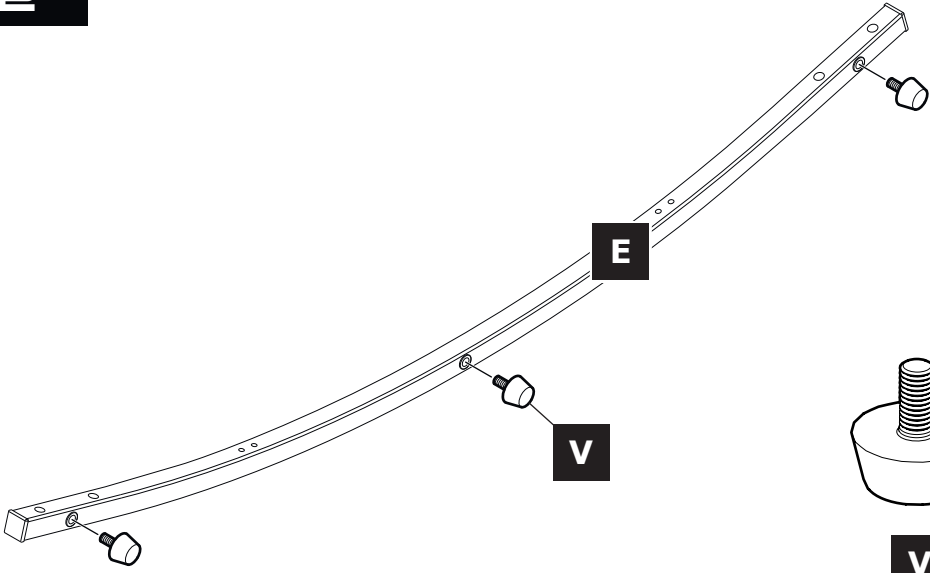

V  
x3

3

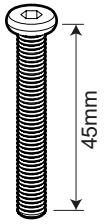
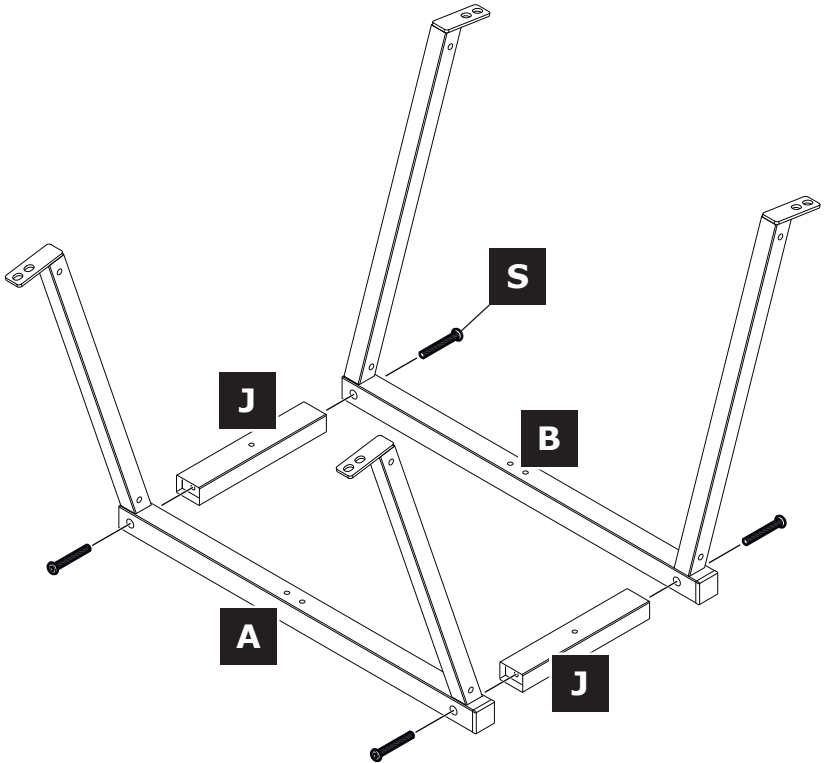

M6

S  
x4

**4**

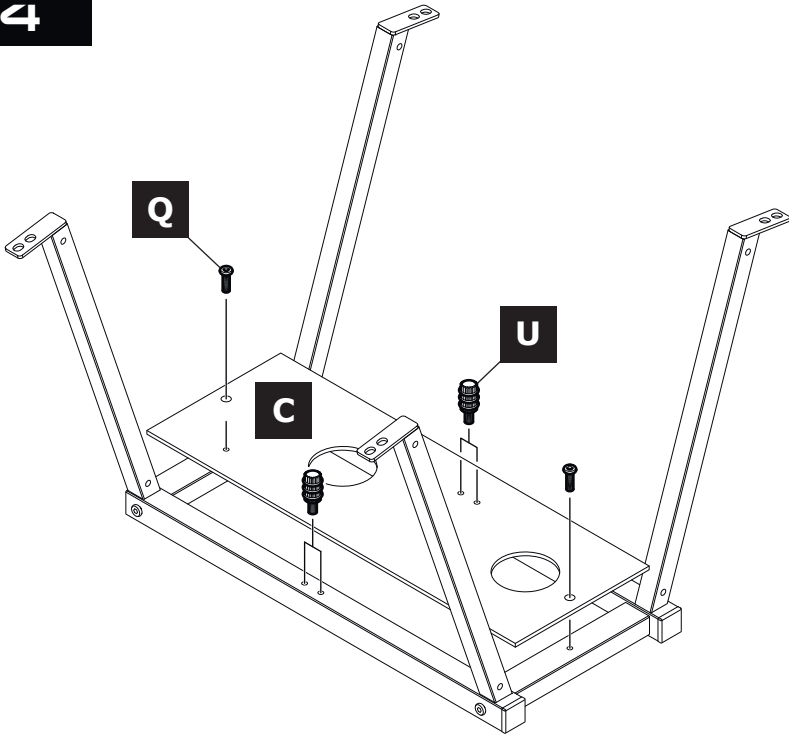

**5**

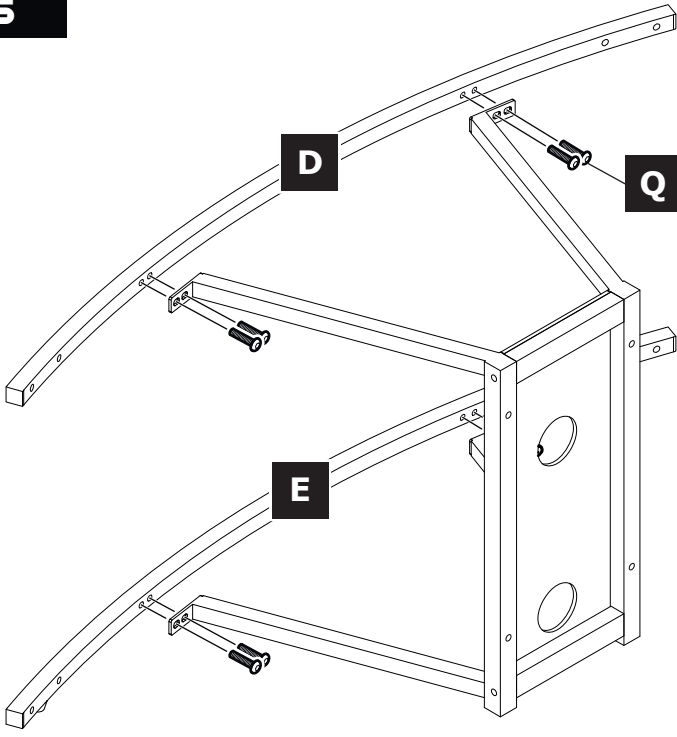

**6**

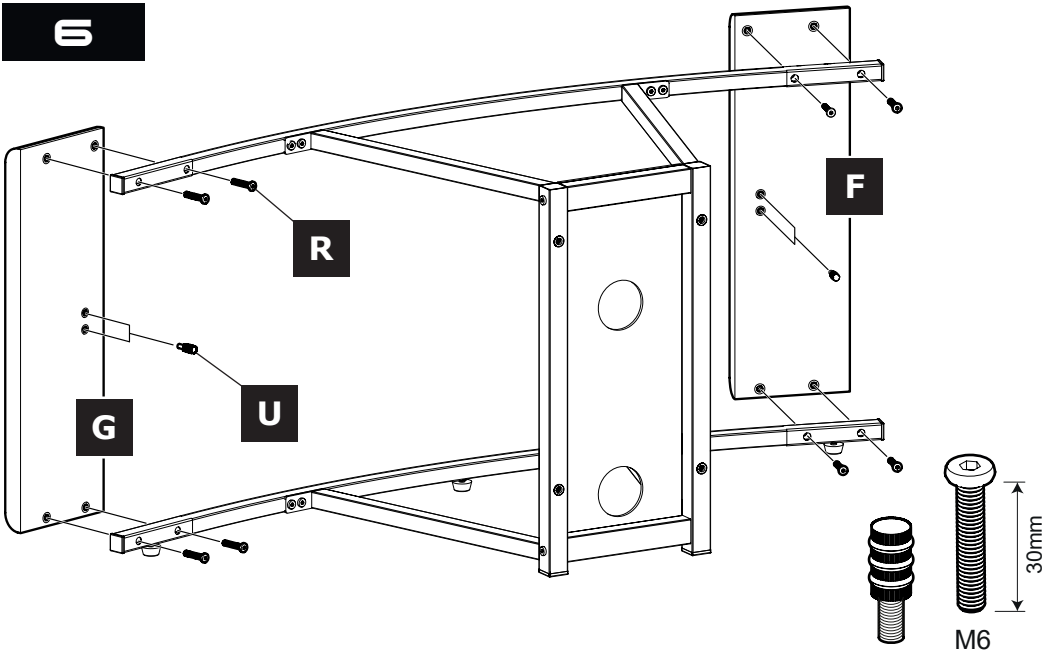

**U**  
x2

**R**  
x8

**7**

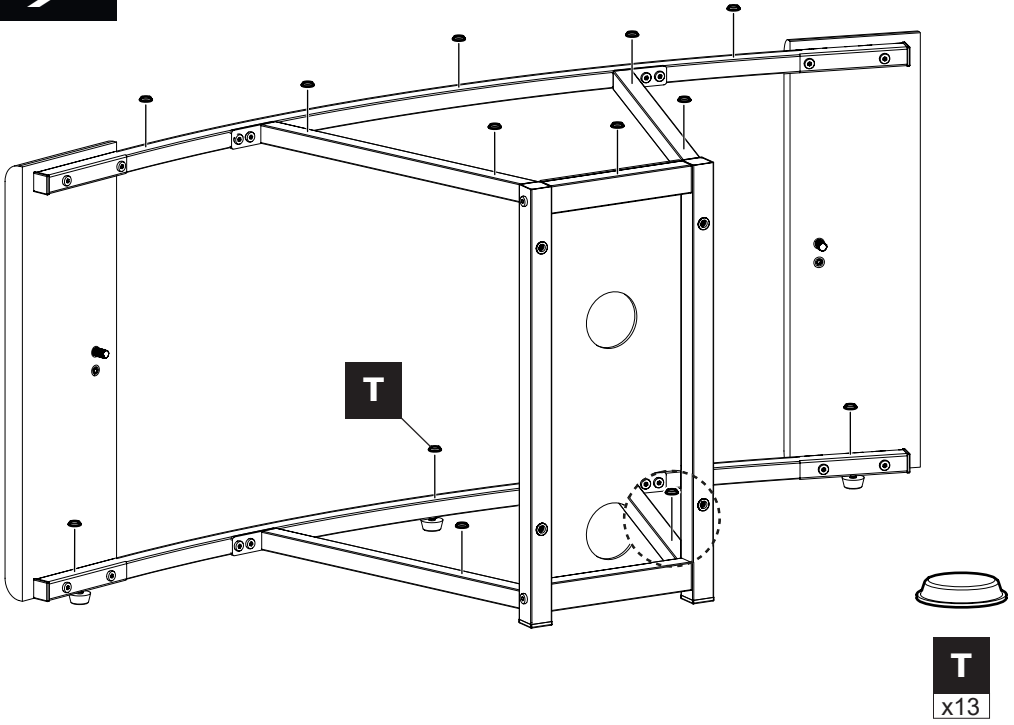

**T**  
x13

**8**

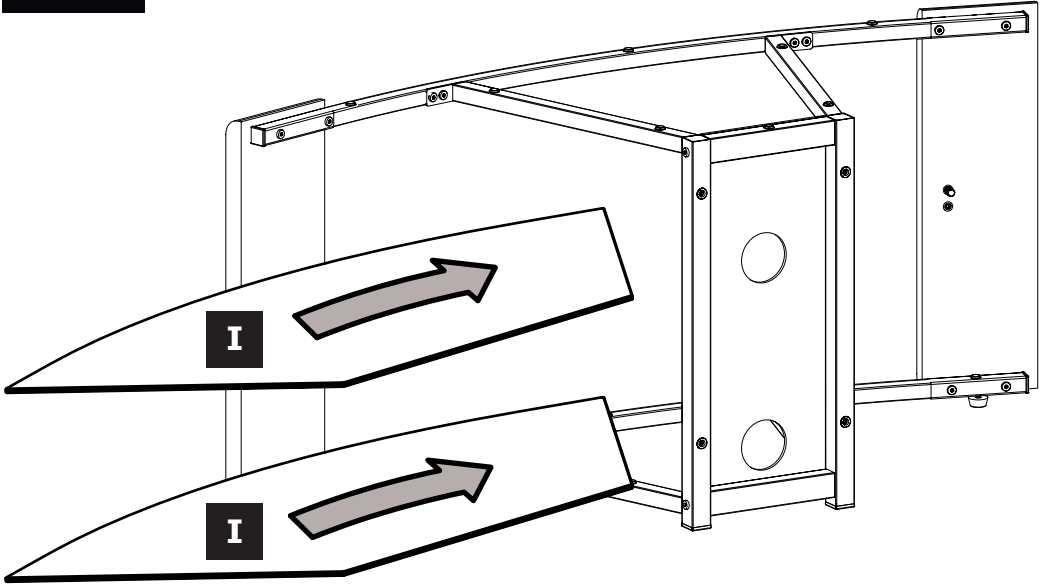

**9**

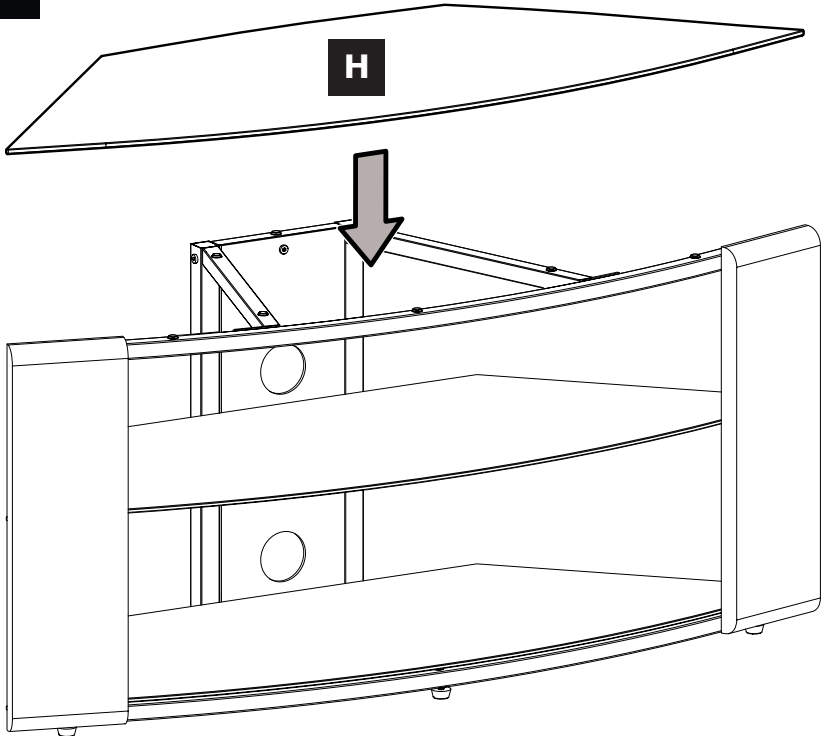



10

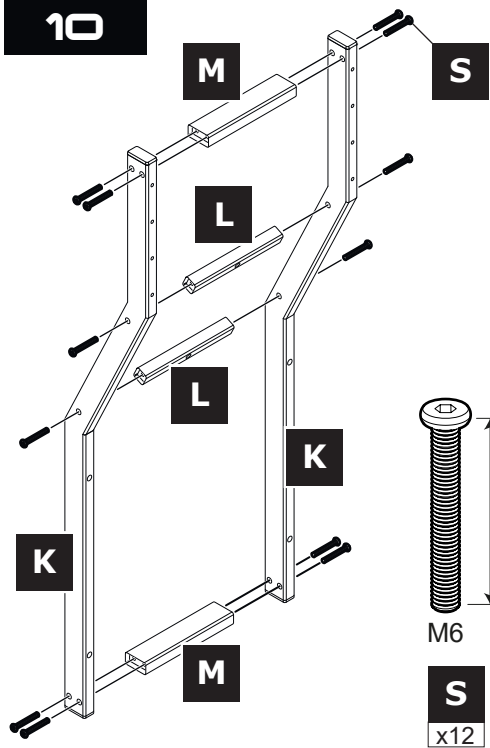

11

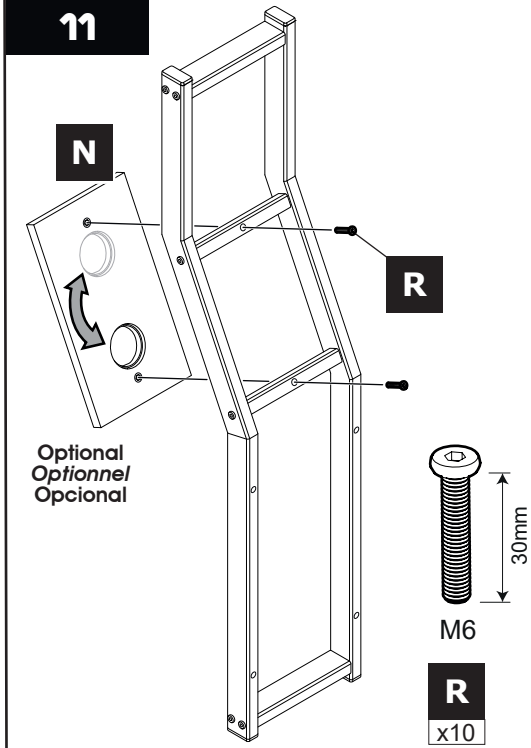

12

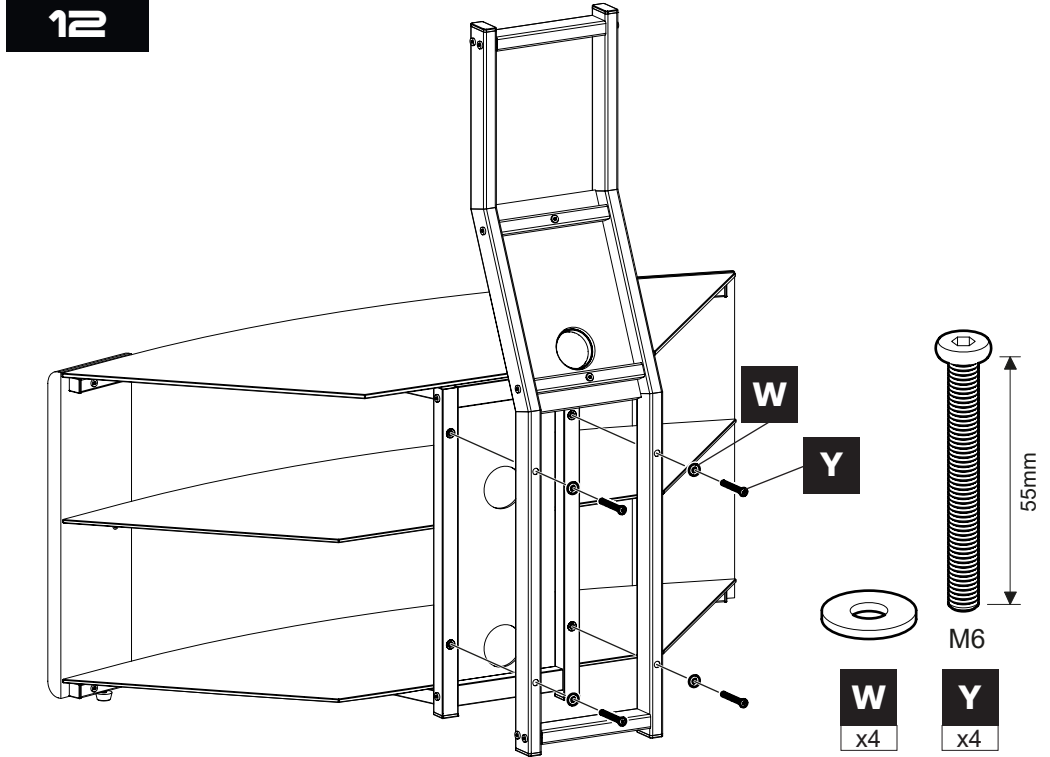



Please consider the size of your TV before fixing plate **O**. See below for guide.  
 Veuillez prendre en compte la taille de votre TV avant de fixer la plaque **O**. Consultez le guide ci-dessous.  
 Considere por favor el tamaño de su TV antes de fijar la placa **O**. Ver la guía más abajo.

Recommended for Extra Large TV  
 Recommandé pour une TV de très grandes dimensions  
 Recomendado para televisores extra grandes

Recommended for Large TV  
 Recommandé pour une TV de grandes dimensions  
 Recomendado para televisores grandes

Recommended for Medium TV  
 Recommandé pour une TV de moyennes dimensions  
 Recomendado para televisores medianas

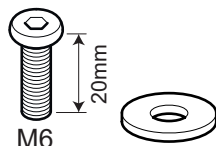
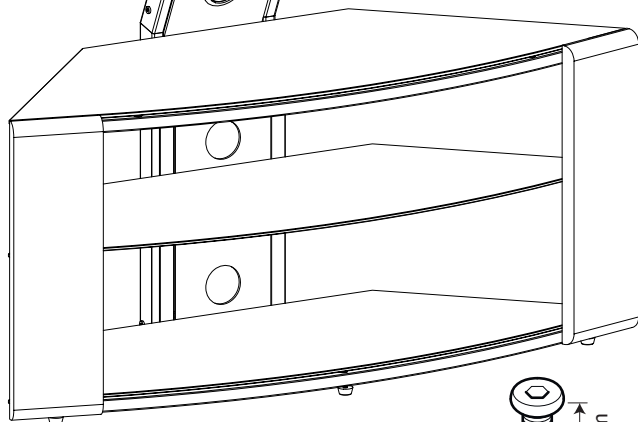
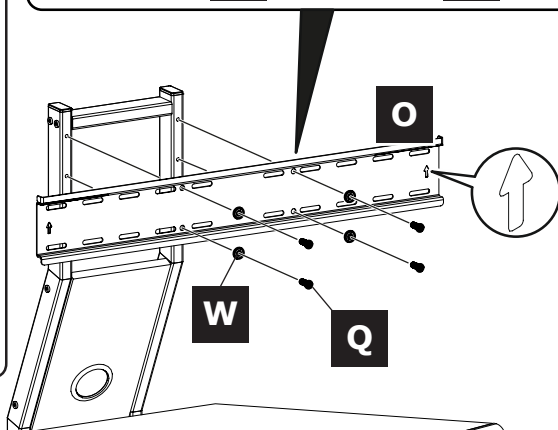
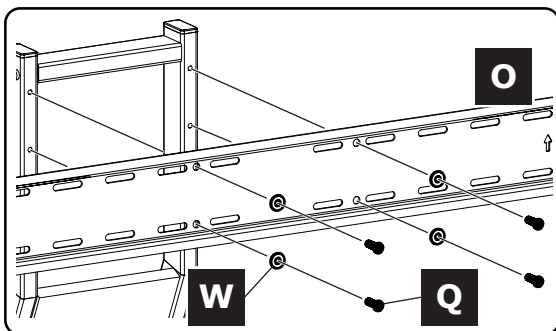

# 14

**No Spacers**  
**Pas de séparateur**  
**Sin espaciadores**

For TVs with flat / unobstructed back  
 Pour des téléviseurs aux dos plats et non obstrués  
 Para TVs con la parte posterior plana / sin obstáculos

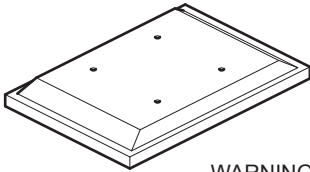

**Spacers**  
**Séparateurs**  
**Espaciadores**

For TVs with irregular / obstructed back  
 Pour des téléviseurs aux dos irréguliers et non obstrués  
 Para TVs con la parte posterior irregular / con obstáculos

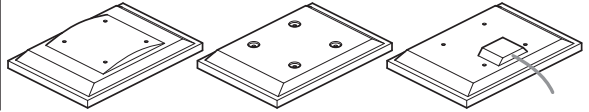

**WARNING / AVERTISSEMENT / ADVERTENCIA**

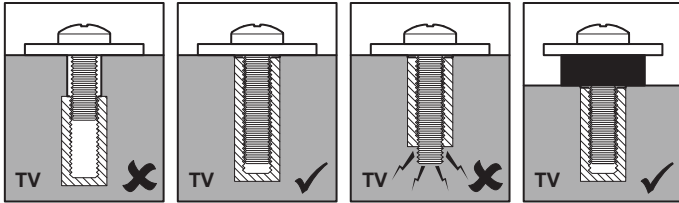

After completing step 14 you will have fittings left over, please keep for future reference.  
 Après avoir complété l'étape 14 il vous restera des pièces d'assemblage, conservez-les.  
 Después de completar el paso 14 usted tendrá conexiones sobrantes, por favor guarde para futura referencia.

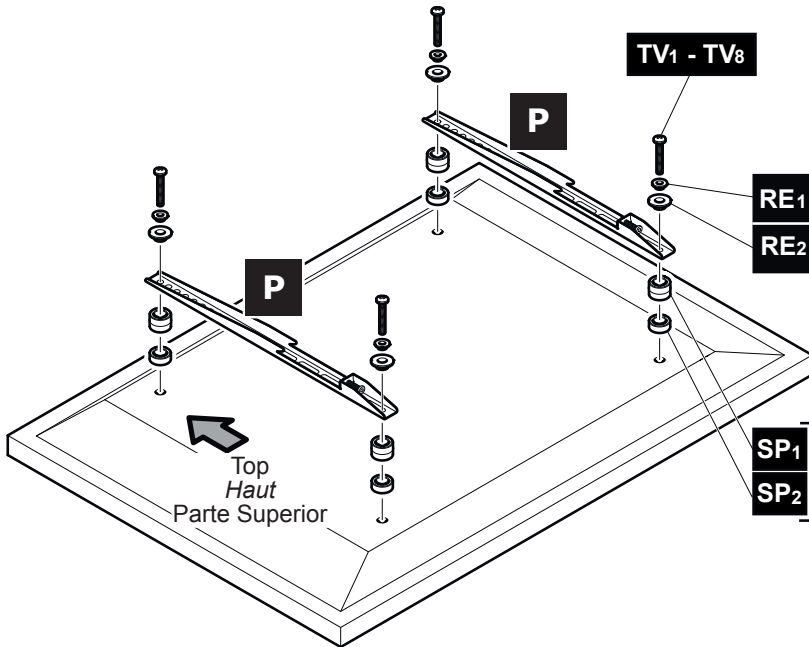

	TV <sub>1</sub> -TV <sub>2</sub>	TV <sub>3</sub> -TV <sub>6</sub>	TV <sub>7</sub> -TV <sub>8</sub>
RE <sub>1</sub>	✓	✗	✗
RE <sub>2</sub>	✓	✓	✗

Do you need RE1 or RE2?  
 Avez-vous besoin de RE1 ou RE2?  
 Necesitas RE1 o RE2?

SP<sub>1</sub> If required  
 Si nécessaire  
 SP<sub>2</sub> Si se requiere

Attach the bracket to the back of your TV using suitable screw, reducer and spacer combinations.  
 Attachez l'applique au dos de votre téléviseur en utilisant une combinaison de vis, de séparateurs et de joints adaptés.  
 Coloque los soportes a la parte posterior de su TV usando la combinación adecuada de tornillo, reductor y espaciador.

