

ca.orbitalholdings.com

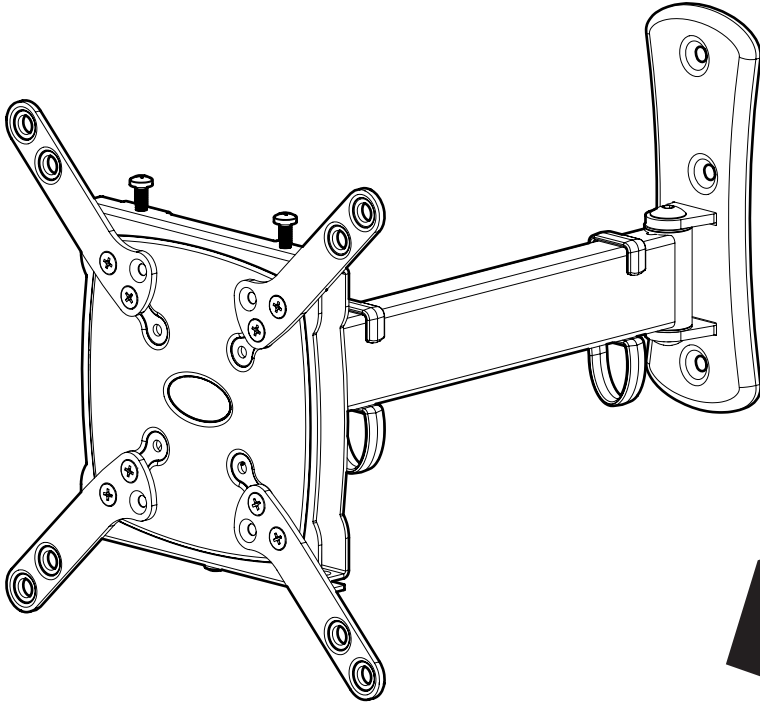

468283 rev04



Read through ALL instructions before commencing installation.



Veuillez lire au préalable TOUTES les instructions avant de commencer l'installation.



Please don't return me!
S'il vous plaît, ne me renvoyer pas!

If you need advice, parts or support,
contact our friendly team:

Si vous avez besoin de conseils, de pièces ou
d'assistance, contactez notre équipe sympathique:

1-800 601 8450 • ca.orbitalholdings.com



Assembly Overview
Vue d'ensemble du montage

Fit the TV Mounting Plate
Ajustez la plaque de montage du téléviseur

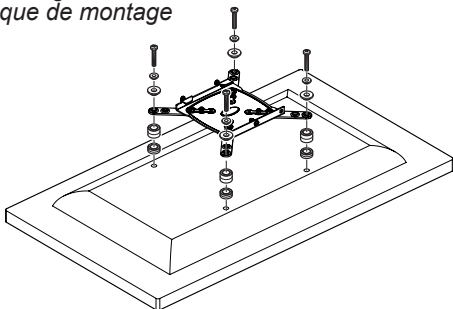

Fit the Wall Plate
Ajustez la plaque murale

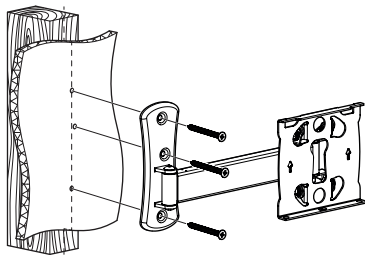

Connect the TV
Connectez le téléviseur

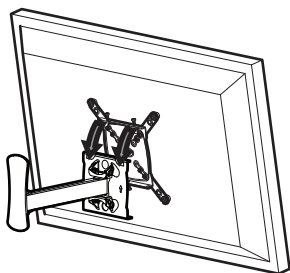

Suitable Wall Types
Catégories de murs adaptés au produit

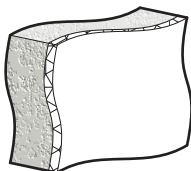

Solid Wall
Murs pleins



Wood Stud
Montants en bois

Tools Recommended
Outils conseillés



Stud Finder
Localisateur de montants

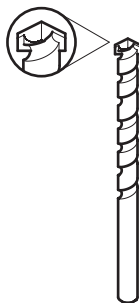

Ø10mm (25/64")
Masonry
Maçonnerie

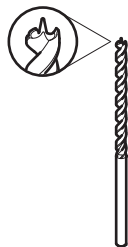

Ø3mm (1/8")
Wood
Bois

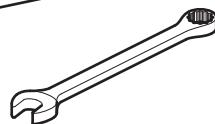
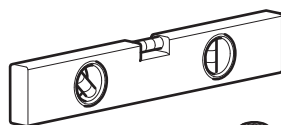
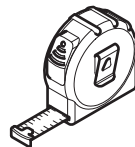
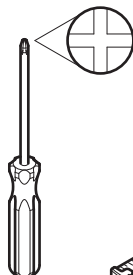
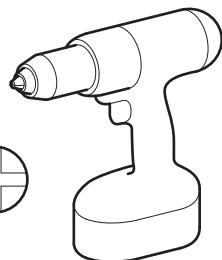

Index

1 Measure the TV fixing holes
Mesurez les trous de fixation du téléviseur

2 Preparing the TV Mounting Plate
Préparez la plaque de montage du téléviseur

3 Fitting the TV Mounting Plate
Ajustez la plaque de montage du téléviseur

4 Fitting the Wall Plate
Ajustez la plaque murale

5 Connecting the TV
Connectez le téléviseur

Retain all packaging in case the bracket needs to be returned.

Contents may vary from photography/illustrations.

You will not need all these parts, so expect there to be some left over depending upon the specifications of your TV.

This product is intended for indoor use only. Use of this product outdoors could lead to failure and personal injury.

It is the responsibility of the installer to ensure that the mounting wall is of a suitable standard and void of any services (e.g. gas, electricity, water, etc).

Orbital accepts no responsibility for any damage or loss caused by installing this product in a substandard wall.

Conservez tous les emballages au cas où vous deviez retourner le support en boutique.

Il est possible que le contenu diffère de la photographie ou de l'illustration.

Vous n'aurez pas besoin de tous les éléments. Certains ne seront donc pas utilisés en fonction des spécificités de votre téléviseur.

Ce produit est destiné à une utilisation en intérieur uniquement. Utiliser ce produit en extérieur présente des risques de pannes et de blessures.

Il incombe à l'installateur de veiller à ce que le support soit conforme aux normes applicables et tienne compte de tout élément technique en présence (par exemple, gaz, électricité, eau, etc.).

Orbital décline toute responsabilité en cas de dommages ou de pertes causés par l'installation du produit sur un support non conforme.

Boxed Parts
Éléments emballés

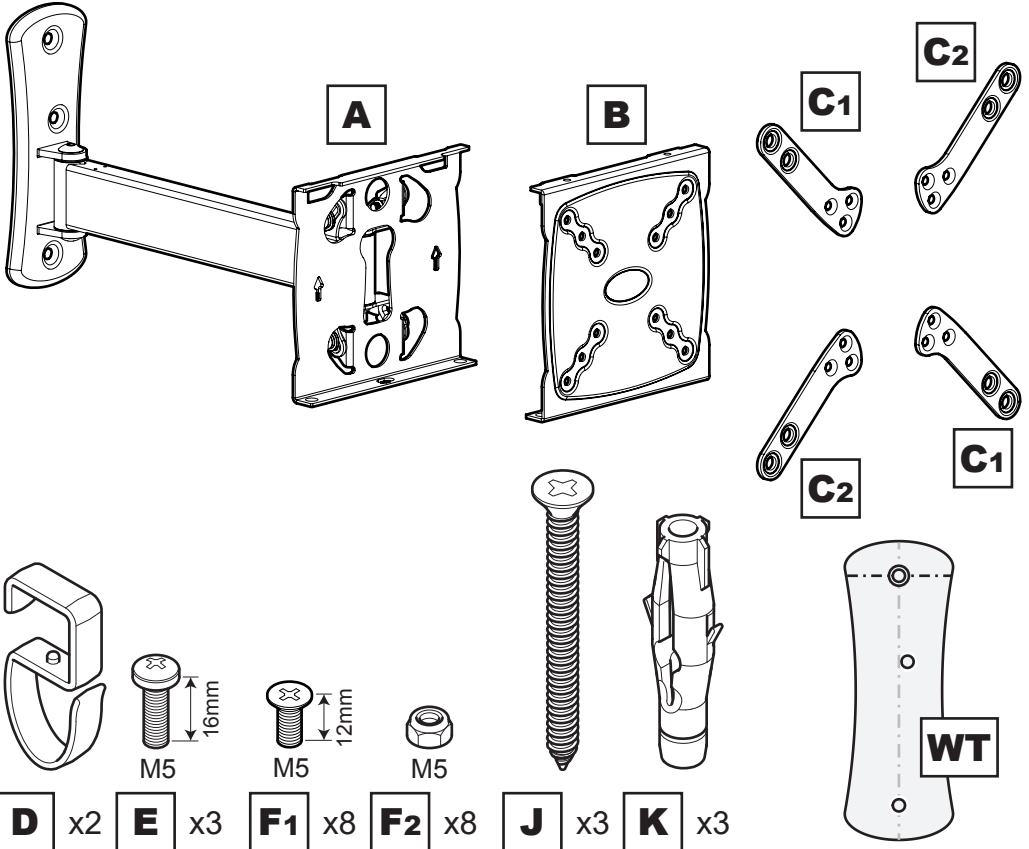

TV Screws, Reducers and Spacers
Vis du téléviseur, raccords de réduction et cales d'écartement

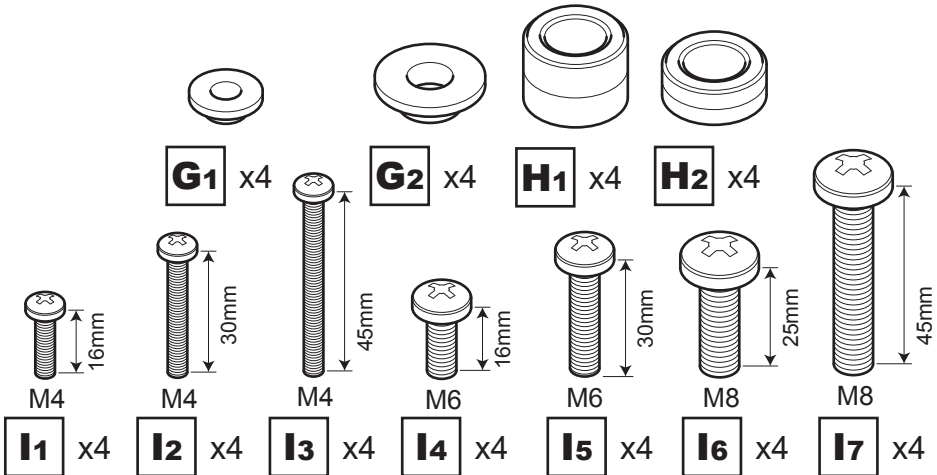

1

Measure the TV fixing holes
Mesurez les trous de fixation du téléviseur

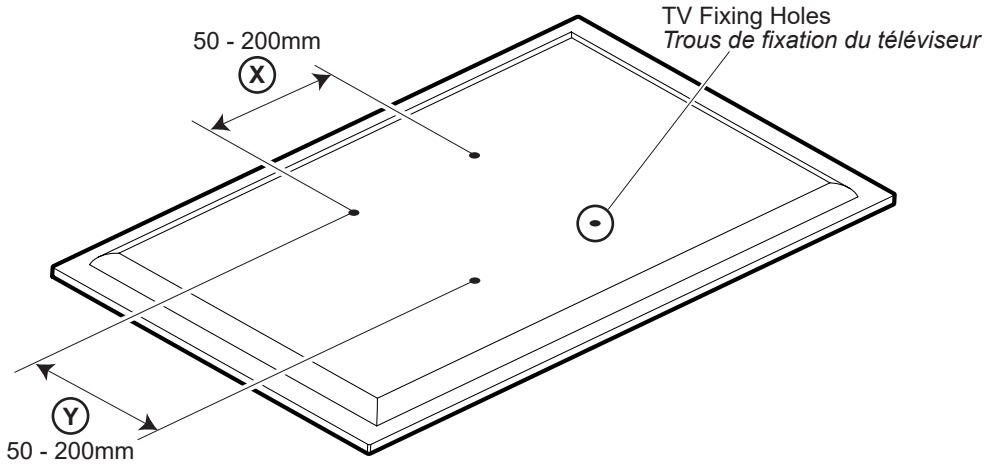

If width **(X)** is greater than 200mm or height **(Y)** greater than 200mm
STOP installation now and contact the customer helpline.



*Si la profondeur **(X)** est supérieure à 200 mm ou que la hauteur **(Y)** est supérieure à 200 mm, veuillez immédiatement **ARRÊTER** l'installation et contacter la ligne d'assistance du service à la clientèle.*

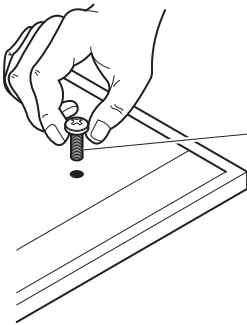

M4 =	I1/I2/I3
M6 =	I4/I5
M8 =	I6/I7

You are provided with 3 diameters of TV fixing screws, **M4**, **M6** and **M8**. Determine the screw diameter that fits and remember for step 3.

*Vous disposez de vis de fixation de 3 diamètres différents, **M4**, **M6** et **M8**. Déterminez le diamètre de vis adapté et mettez-les de côté pour l'étape 3.*

Please note that when the TV wall mount is flat to wall your TV will be 244mm off centre to the wall plate. Please consider this before you drill the wall.



Veuillez noter que lorsque le support mural du téléviseur est posé à plat contre le mur, votre téléviseur sera décentré de 244 mm par rapport à la plaque murale. Veuillez tenir compte de ceci avant de percer le mur.

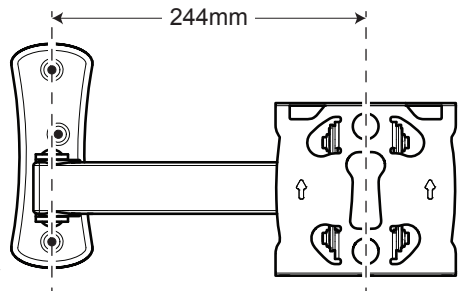

Centre of TV
 Centre de la télévision

2

Preparing the TV Mounting Plate Préparez la plaque de montage du téléviseur

Use the option that fits your TV / Choisissez l'option adaptée à votre téléviseur

OPTION 1 / OPTION 1

- X 50mm x Y 50mm
- X 75mm x Y 75mm
- X 100mm x Y 100mm

OPTION 2 / OPTION 2

- X 100mm x Y 200mm
- X 200mm x Y 100mm

OPTION 3 / OPTION 3

- X 200mm x Y 200mm

If in any doubt please call the customer helpline.

En cas de doute, veuillez contacter la ligne d'assistance du service à la clientèle.

OPTION 1 / OPTION 1

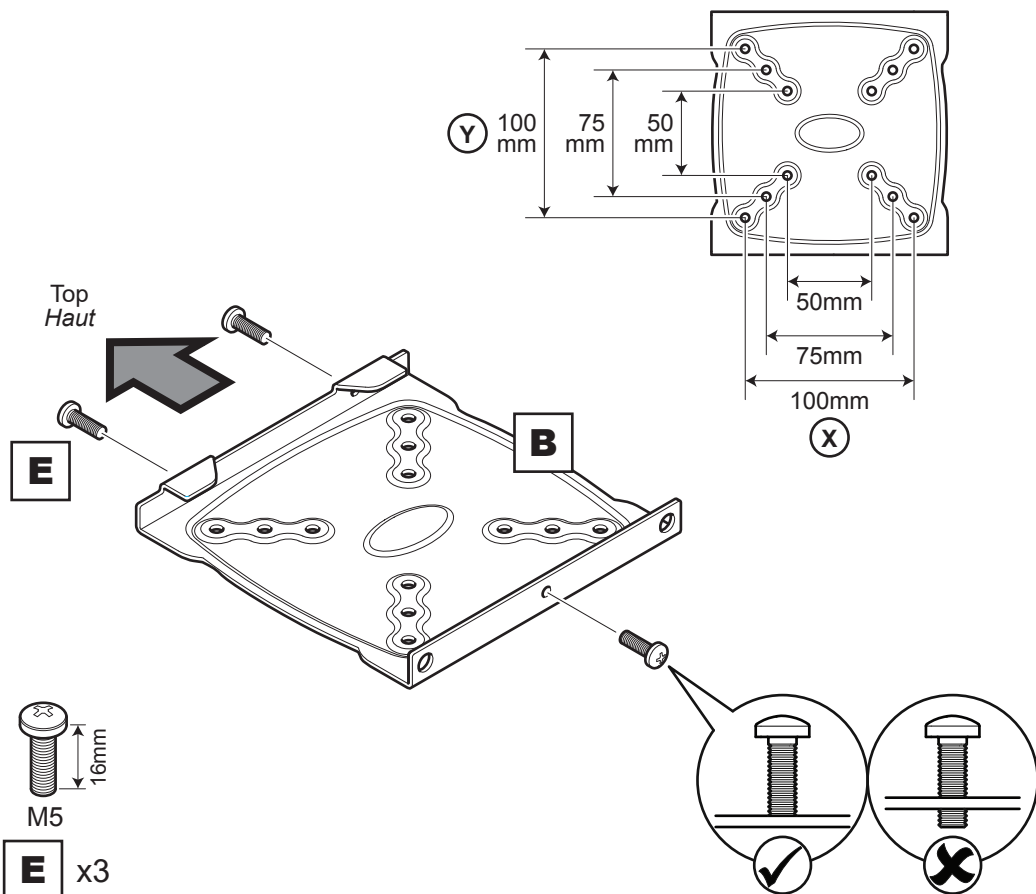

OPTION 2 / OPTION 2

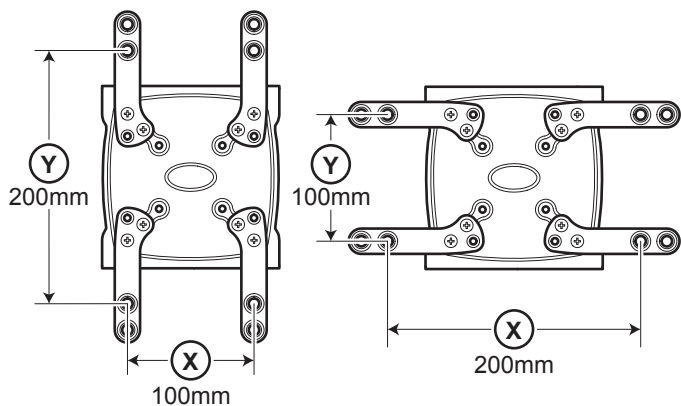

OPTION 3 / OPTION 3

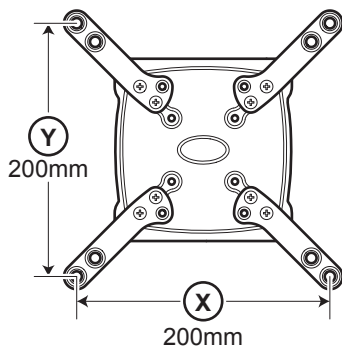

Example shown is 200 x 200 fixings.
L'exemple montre des fixations de 200 x 200.

Top
 Haut

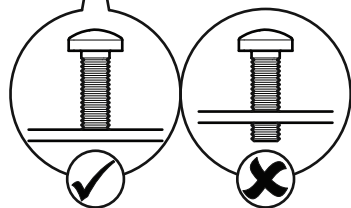
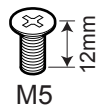
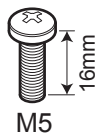
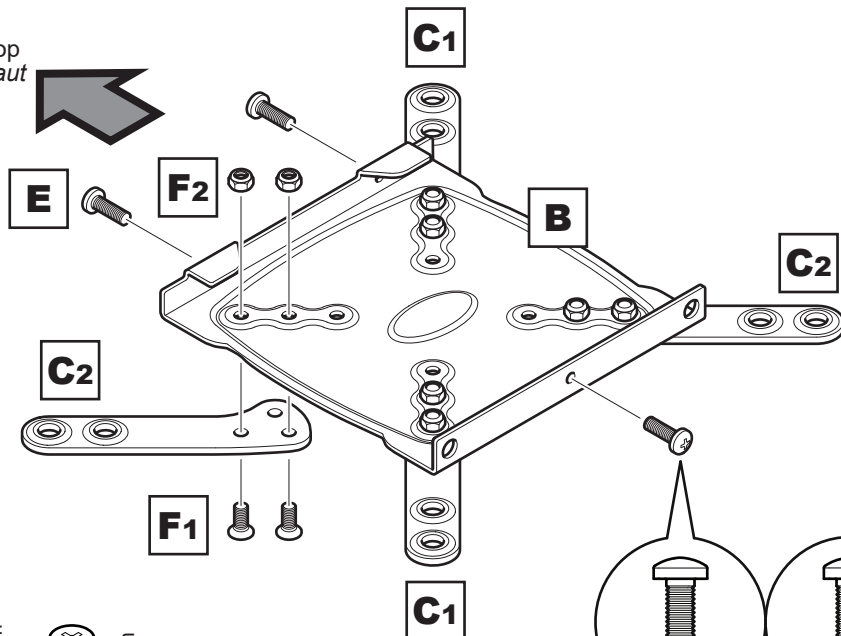

- E** x3
- F1** x8
- F2** x8

3**Fitting the TV Mounting Plate**
*Ajustez la plaque de montage du téléviseur***No Spacers**
Aucune cale d'écartement

For TVs with flat / unobstructed back
Pour les téléviseurs à écran plat ou sans couvercle à l'arrière

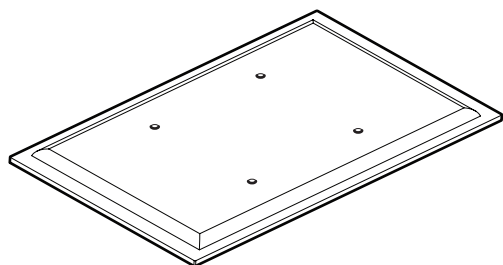
**Spacers**
*Cales d'écartement***H1/H2**

For TVs with irregular / obstructed back
Pour les téléviseurs classiques ou avec couvercle à l'arrière

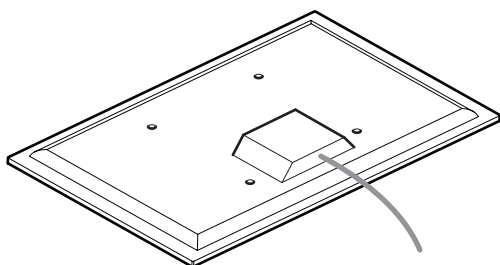
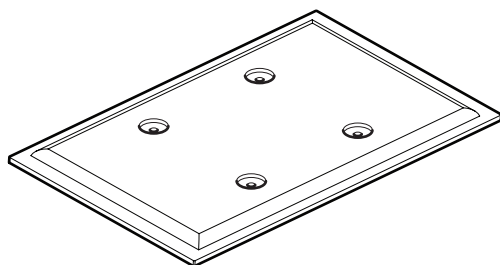
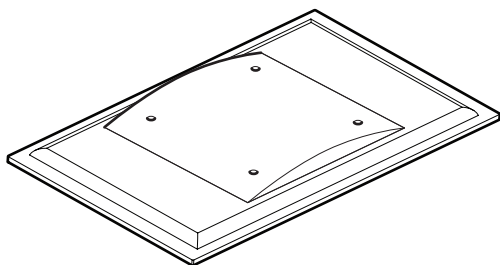
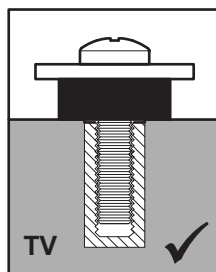
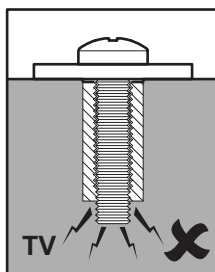
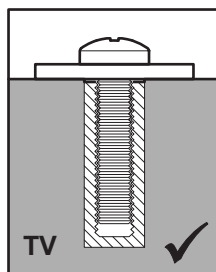
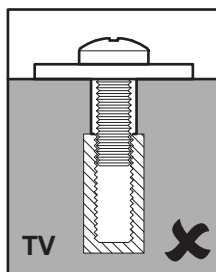
**WARNING / AVERTISSEMENT**

Attach the mounting plate to the back of your TV using suitable screw, reducer and spacer combinations.

Fixez la plaque de fixation à l'arrière de votre téléviseur à l'aide des vis adaptées, du raccord de réduction et des cales d'écartement.

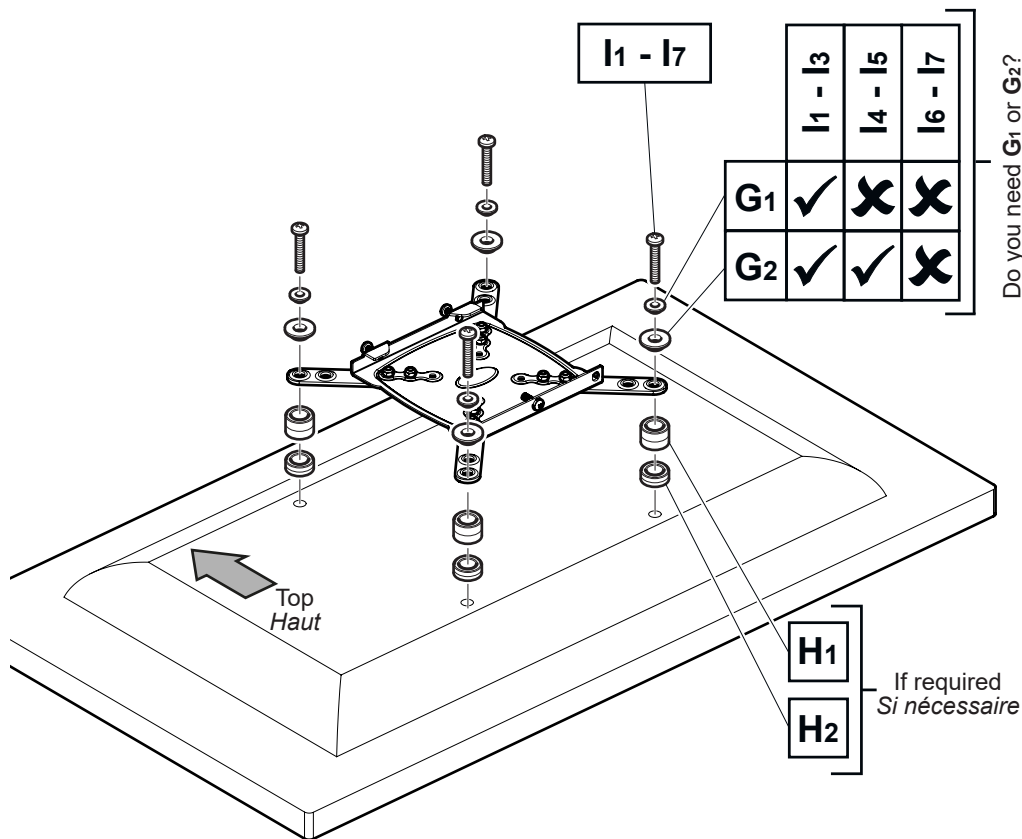

After completing step 3 you will have fittings left over, please keep for future reference.
Après avoir terminé l'étape 3, vous aurez des raccords excédentaires. Conservez-les pour plus tard.

4

Fitting the Wall Plate Ajustez la plaque murale

Solid Wall / Murs pleins

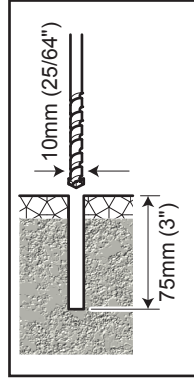
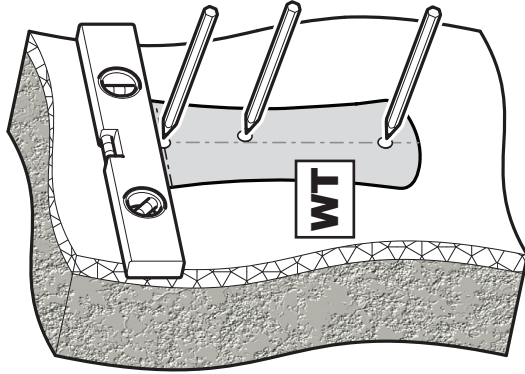

Remove dust from hole.
Éliminez toute trace de poussière du mur.

Wood Stud / Montants en bois

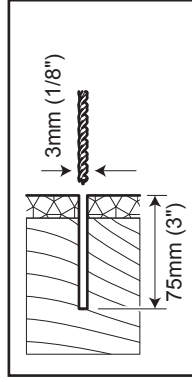
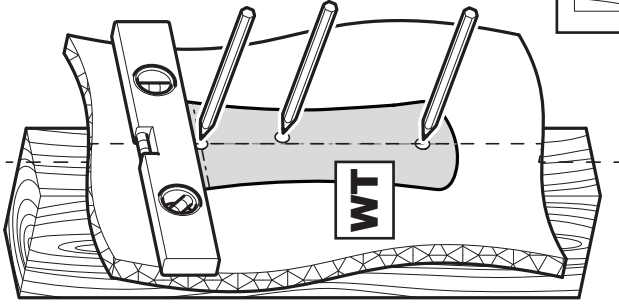

Ensure you drill in the centre of the wood stud.
Veillez à percer au centre du montant en bois.



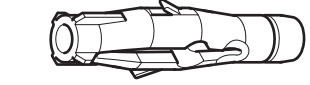
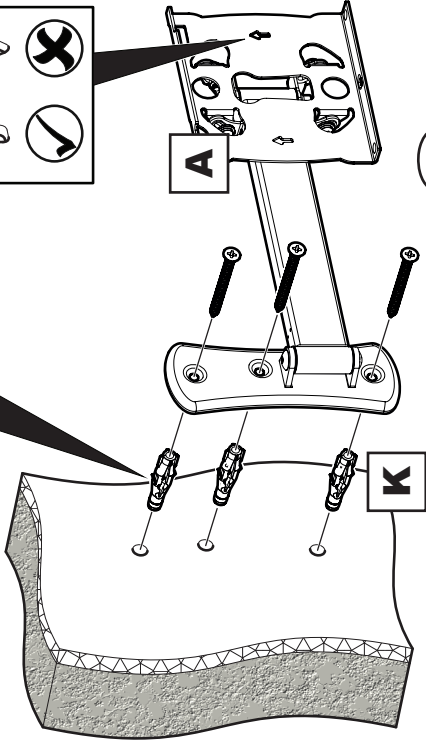
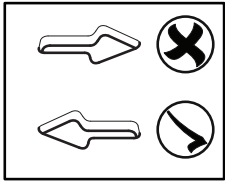
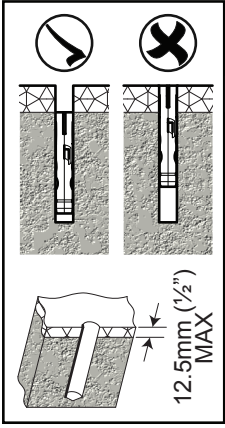

J

K



Lubricate screw thread with soap.
Lubrifiez le pas de vis avec du savon.

DO NOT overtighten screws.
Tighten screws by hand only.
NE serrez PAS trop les vis.
Serrez les vis à la main uniquement.



J x3

K x3

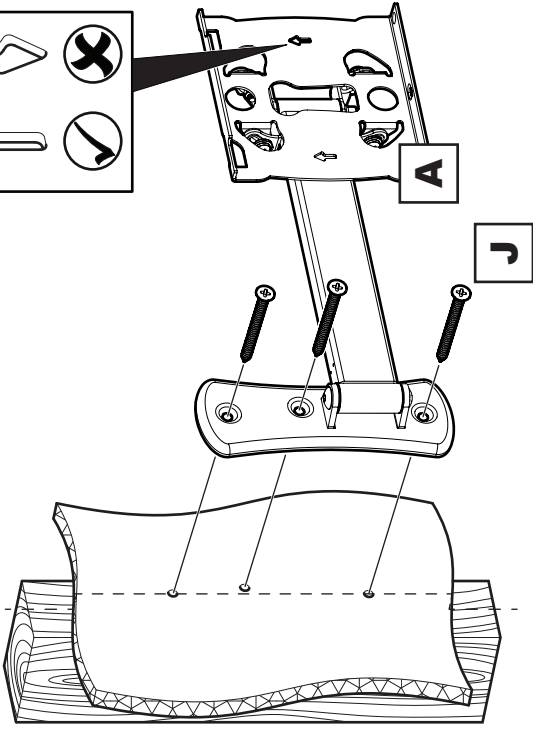
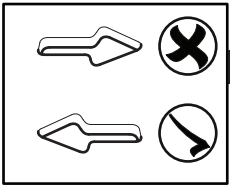

Lubricate screw thread with soap.
Lubrifiez le pas de vis avec du savon.

DO NOT overtighten screws.
Tighten screws by hand only.
NE serrez PAS trop les vis.
Serrez les vis à la main uniquement.

DO NOT use wall plugs in a wood stud wall.
N'utilisez PAS de cache murale dans un montant en bois



J x3



5 Connecting the TV Connectez le téléviseur

Attaching and Locking
Attachez et verrouillez

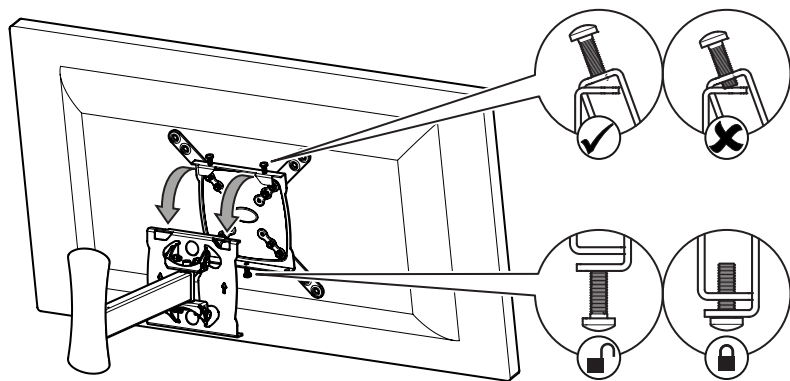

TV Levelling
Mise au niveau du téléviseur

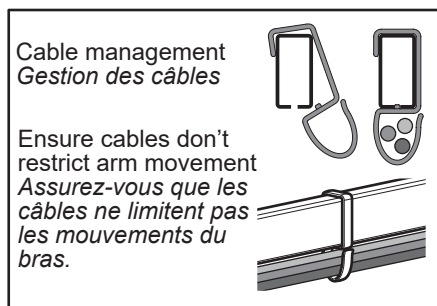

Lock Tilt (optional)
Verrouillez l'inclinaison (optionnel)

