

www.avfgroup.com

467928 rev01

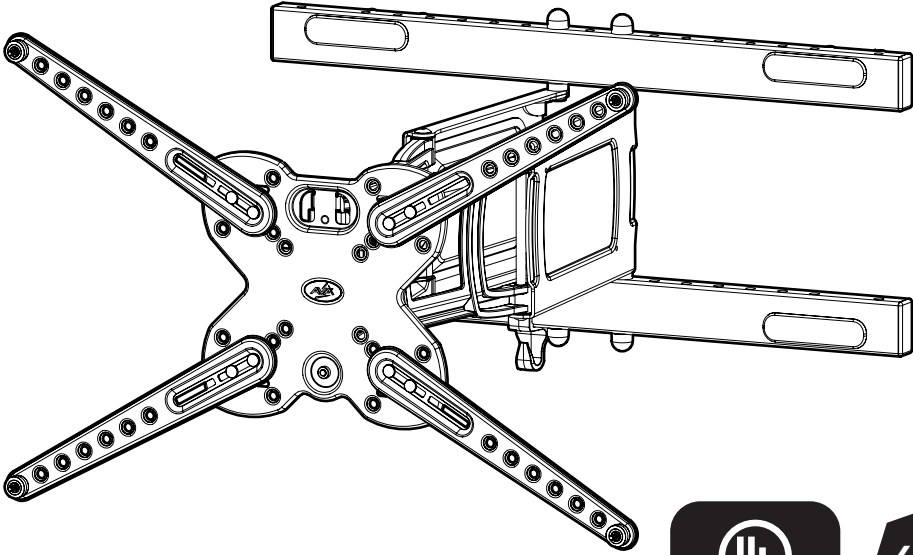

Read through **ALL** instructions before commencing installation.

If you have any questions about this product or issues with installation, contact the customer services help line before returning this product to the store.



This bracket is intended for use with televisions weighing **Maximum 60kg (132lbs)**. Use with products heavier than maximum weights may result in instability causing possible injury.



Lea **TODAS** las instrucciones antes de comenzar la instalación.

Si tiene alguna pregunta sobre el producto o problemas con la instalación, llame a la línea de servicio al consumidor antes de devolverlo.



Este soporte es para usar con televisores con un peso máximo de **60kg (132lbs)**. El uso con productos más pesados que el peso máximo puede suponer inestabilidad y posibles lesiones.

CUSTOMER SERVICES HELP LINE NUMBER: **1-800 667 0808 (USA)**  
NUMERO DE SERVICIO DE ATENCION AL CLIENTE:



DO NOT remove  
until step 2  
*No lo quite hasta  
llegar al paso no. 2*

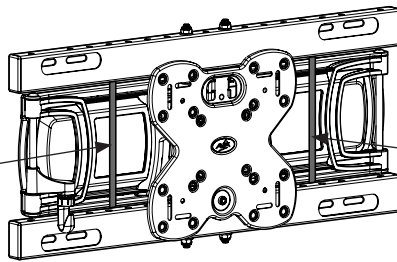

DO NOT remove  
until step 2  
*No lo quite hasta  
llegar al paso no. 2*

### Assembly Overview *Ensambladura General*

Fit the TV Mounting Plate  
*Fije La Placa De Montaje De TV*

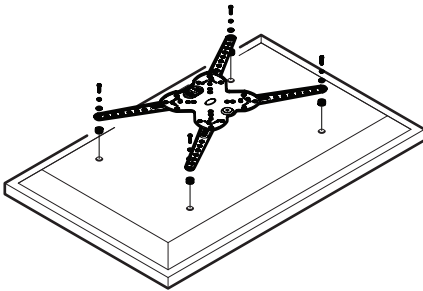

Determine your TV position  
*Determine la posición de su TV*

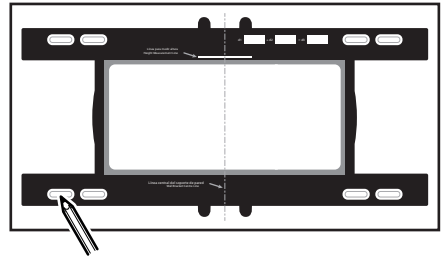

Fit the Wall Bracket  
*Fije el Soporte de Pared*

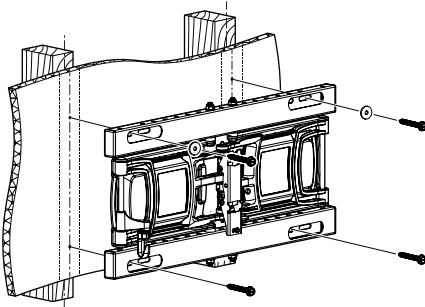

Connect the TV  
*Conecte la TV*

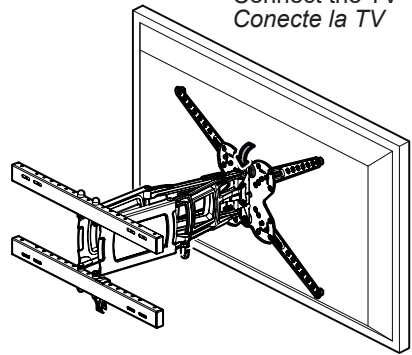

### Suitable Wall Types *Tipos adecuados de pared*

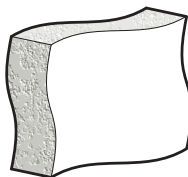

Solid Wall  
*Pared sólida*

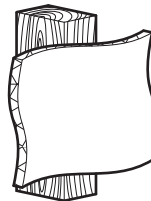

Wood Stud  
*Viga de madera*

## Index Índice

**1** Measure the TV fixing holes Width and Height  
*Mida los orificios de su TV, lo ancho y lo alto*

**2** Preparing the TV Mounting Plate  
*Preparando La Placa De Montaje De TV*

**3** Fitting the TV Mounting Plate  
*Fijando La Placa De Montaje De TV*

**4** Determine your TV position  
*Determine la posición de su TV*

**5** Marking Wall for Drill Points  
*Marcar la Pared Para Punto de Taladro*

**6** Fitting the Wall Bracket  
*Fijando la Placa a la Pared*

**7** Fitting the Wall Bracket Covers  
*Fijando Las Cubiertas Del Soporte De Pared*

**8** Connecting the TV  
*Conectando la TV*

**9** Cable management  
*Manejo de Cable*

Retain all packaging in case the bracket needs to be returned.

Contents may vary from photography/illustrations.

You will not need all these parts, so expect there to be some left over depending upon the specification of your TV.

This product is intended for indoor use only. Use of this product outdoors could lead to failure and personal injury.

It is the responsibility of the installer to ensure that the mounting wall is of a suitable standard and void of any services (eg gas, electricity, water etc).

AVF accept no responsibility for any damage or loss caused by installing this product in a sub standard wall.

*Conserve todos los envasados en caso de que el soporte tenga que ser devuelto.*

*El contenido puede variar de la fotografía/ilustración.*

*No necesitará todas estas partes, espere que sobren algunas según las especificaciones de su TV.*

*Este producto está diseñado para el uso en el interior solamente. El uso de este producto en el exterior podría llevar al fracaso y lesiones personales.*

*Es la responsabilidad del instalador de asegurarse de que la pared de montaje es de un nivel adecuado y carece de todo los servicios (gas, electricidad, agua, etc.).*

*AVF no acepta ninguna responsabilidad por cualquier daño o pérdida causada por la instalación de este producto en una pared inadecuada.*

**Tools Recommended**  
**Herramientas recomendadas**

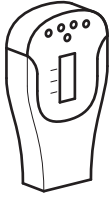

Stud Finder  
 Detector de vigas  
 de madera

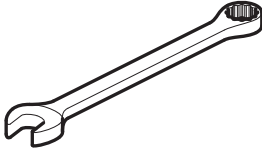

10mm  
 13mm

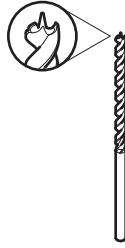
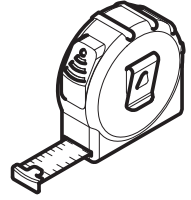
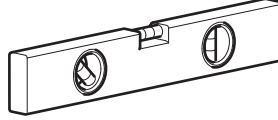

Ø5mm (13/64"  
 Wood  
 Madera

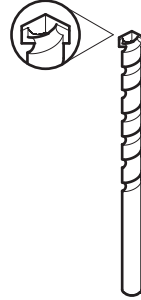

Ø12mm (15/32")  
 Masonry  
 Masonería

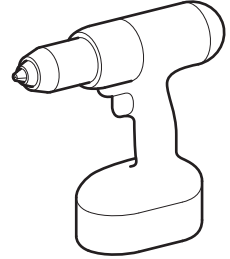

**Boxed Parts**  
**Piezas en la Caja**

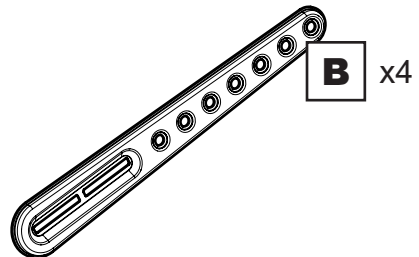
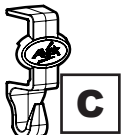
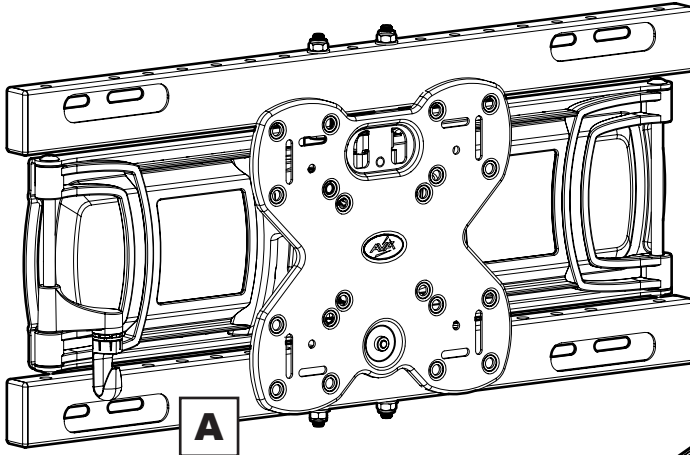

x4



**TV Screws, Reducers and Spacers**  
**Tornillos, Reductores y Espaciadores para TV**



**I1** x4



**I2** x4



**J1** x12



**J2** x4

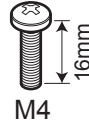

**K1** x4

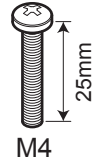

**K2** x4

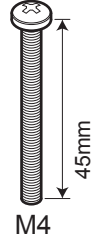

**K3** x4

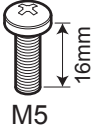

**K4** x4

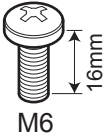

**K5** x4

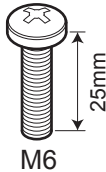

**K6** x4

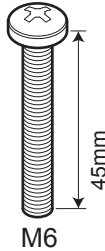

**K7** x4

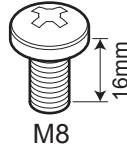

**K8** x4

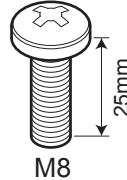

**K9** x4

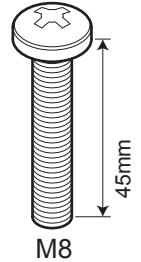

**K10** x4

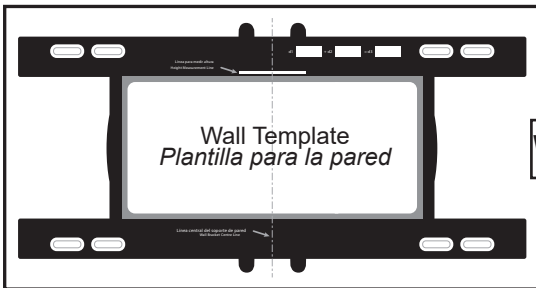

**WT**

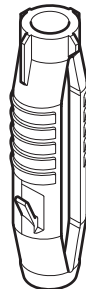

**L** x6

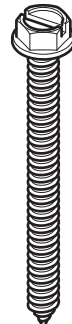

**M** x6



**E** x4



**F** x8



**G** x8



**H** x16



**N** x4

# 1 Measure the TV fixing holes Width and Height *Mida los orificios de su TV, lo ancho y lo alto*

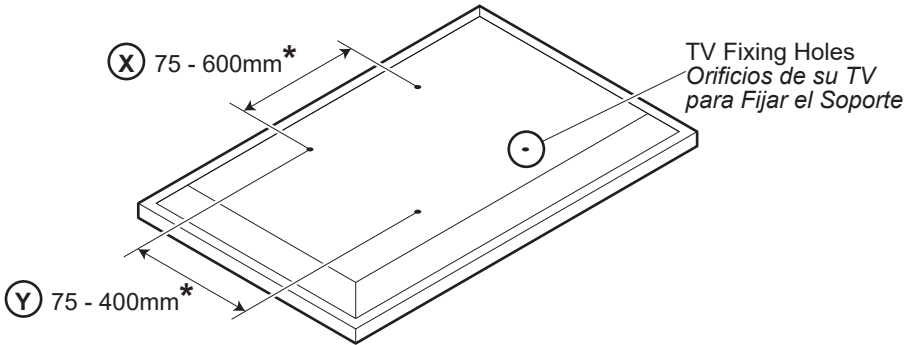

If width **X** is greater than 600mm or height **Y** greater than 400mm  
STOP installation now and contact the customer help line  
*Si la anchura **X** es mayor que 600mm o la altura de **Y** es mayor que 400mm  
DETENGA la instalación inmediatamente y póngase en contacto con la línea de ayuda al cliente*

You are provided with 4 diameters of TV fixing screws, **M4**, **M5**, **M6** and **M8**.

Determine the screw diameter that fits and remember for step 3.

*Se le proporciona con 4 diámetros de tornillos de fijación para su TV, **M4**, **M5**, **M6** and **M8**.*

*Determine el diámetro del tornillo que le quede a su TV y recuérdelo para el paso 3.*

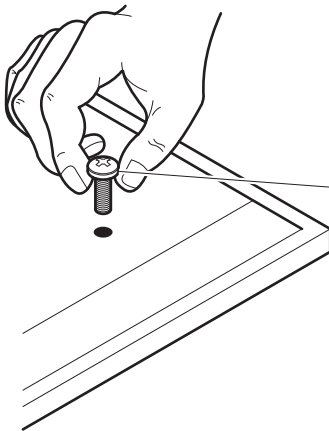

<b>M4 =</b>	<b>K1/K2/K3</b>
<b>M5 =</b>	<b>K4</b>
<b>M6 =</b>	<b>K5/K6/K7</b>
<b>M8 =</b>	<b>K8/K9/K10</b>

After completing step 3 you will have fittings left over, please keep for future reference.

*Después de completar el paso 3 usted tendrá conexiones sobrantes, por favor guarde para futura referencia.*

## 2 Preparing the TV Mounting Plate *Preparando La Placa De Montaje De TV*

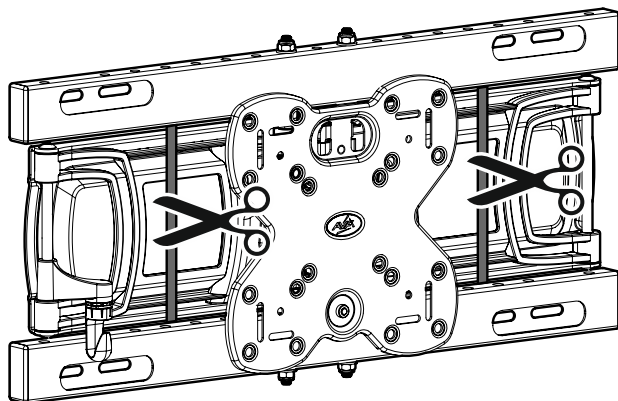

Before you can attach the TV mounting plate to your TV you need to remove the plate from your wall mount.

*Antes de fijar la placa de montaje de TV a su TV, debe extraer la placa del montaje a la pared.*

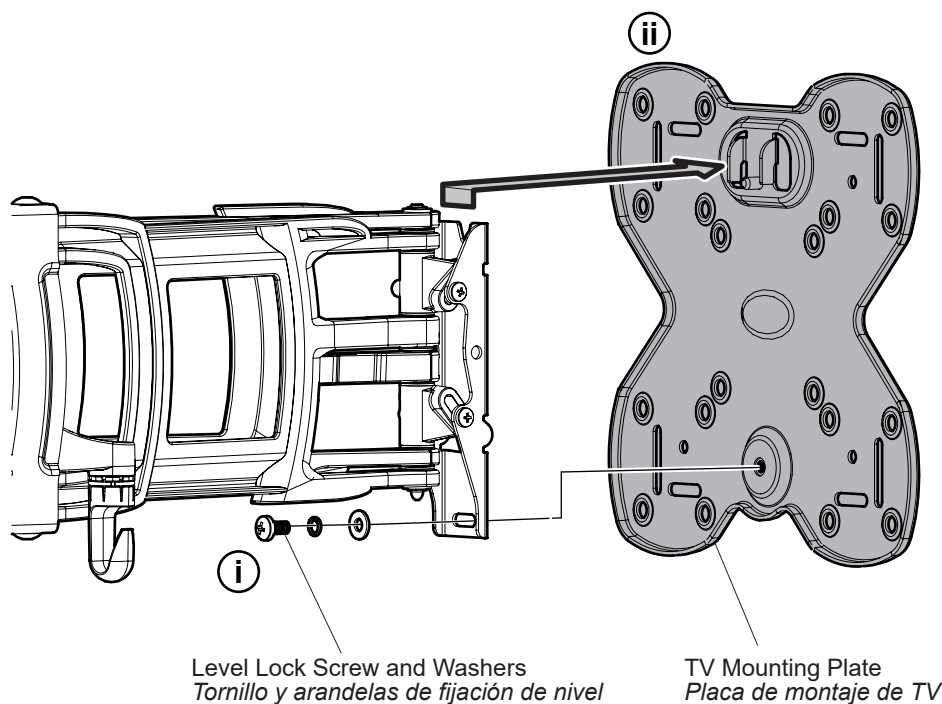

- i** Remove the Level Lock Screw and Washers and safely keep for step 8.  
*Extraiga el tornillo y las arandelas de fijación de nivel y consérvelos para el paso 8.*
- ii** Remove the TV Mounting Plate.  
*Extraiga la placa de montaje de TV.*

Use the option that fits your TV  
*Utilice la opción que mejor se adapte a su TV*

**OPTION 1 / OPCIÓN 1**

- X 75mm x  Y 75mm
- X 100mm x  Y 100mm
- X 100mm x  Y 200mm
- X 200mm x  Y 100mm
- X 200mm x  Y 200mm

**OPTION 2 / OPCIÓN 2**

- X 300mm x  Y 100mm
- X 300mm x  Y 200mm
- X 300mm x  Y 300mm
- X 400mm x  Y 100mm
- X 400mm x  Y 200mm
- X 400mm x  Y 300mm
- X 400mm x  Y 400mm
- X 75-400mm x  Y 75-400mm
- X 600mm x  Y 100mm
- X 600mm x  Y 200mm
- X 600mm x  Y 300mm
- X 600mm x  Y 400mm
- X 400-600mm x  Y 75-400mm
- X 630mm x  Y 310mm

If in any doubt please call the customer help line.  
*Si tiene alguna pregunta, póngase en contacto con atención al cliente.*

**OPTION 1 / OPCIÓN 1**

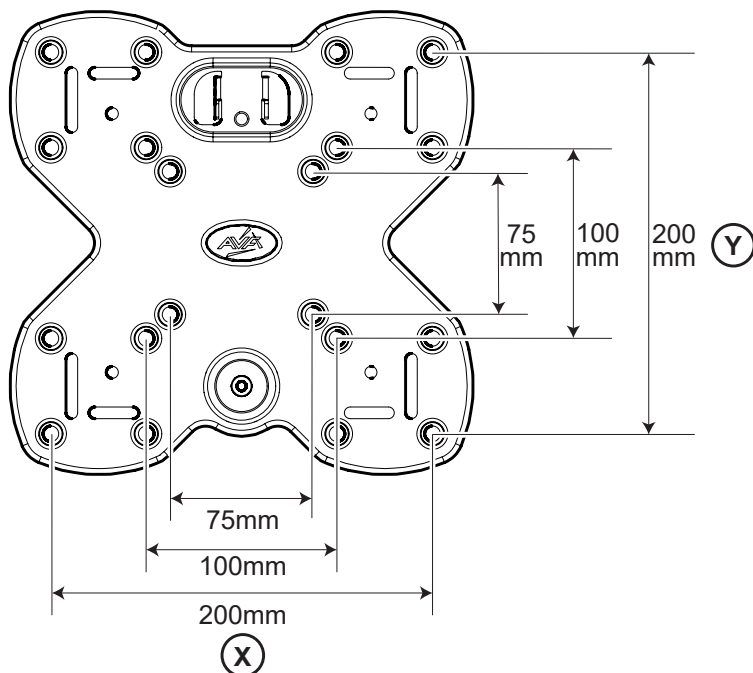

If your TV fixing holes match any of the sizes shown above you will not need to use any adaptors. Please go to step 3.  
*Si los agujeros de fijación de tu TV coinciden con cualquiera de los tamaños mostrados encima, no tendrás que usar ningún adaptador. Por favor, ve al paso 3.*

**OPTION 2 / OPCIÓN 2**



When attaching adaptors **B** you must always use **HOLES x4** and either of the **SLOTS**.  
 Para colocar adaptadores **B** deberá siempre utilizar **ORIFICIOS x4** y alguna de las **RANURAS**.

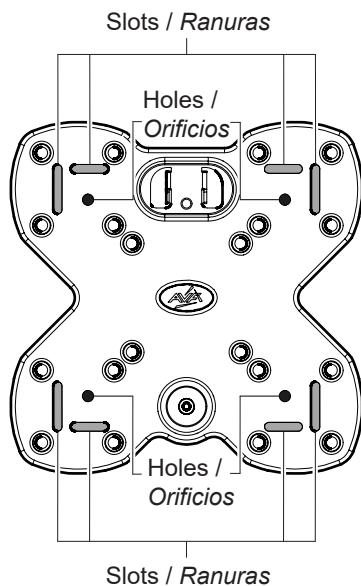

Example shown is 400 x 400 fixings  
 El ejemplo se muestra con fijaciones de 400mm x 400mm

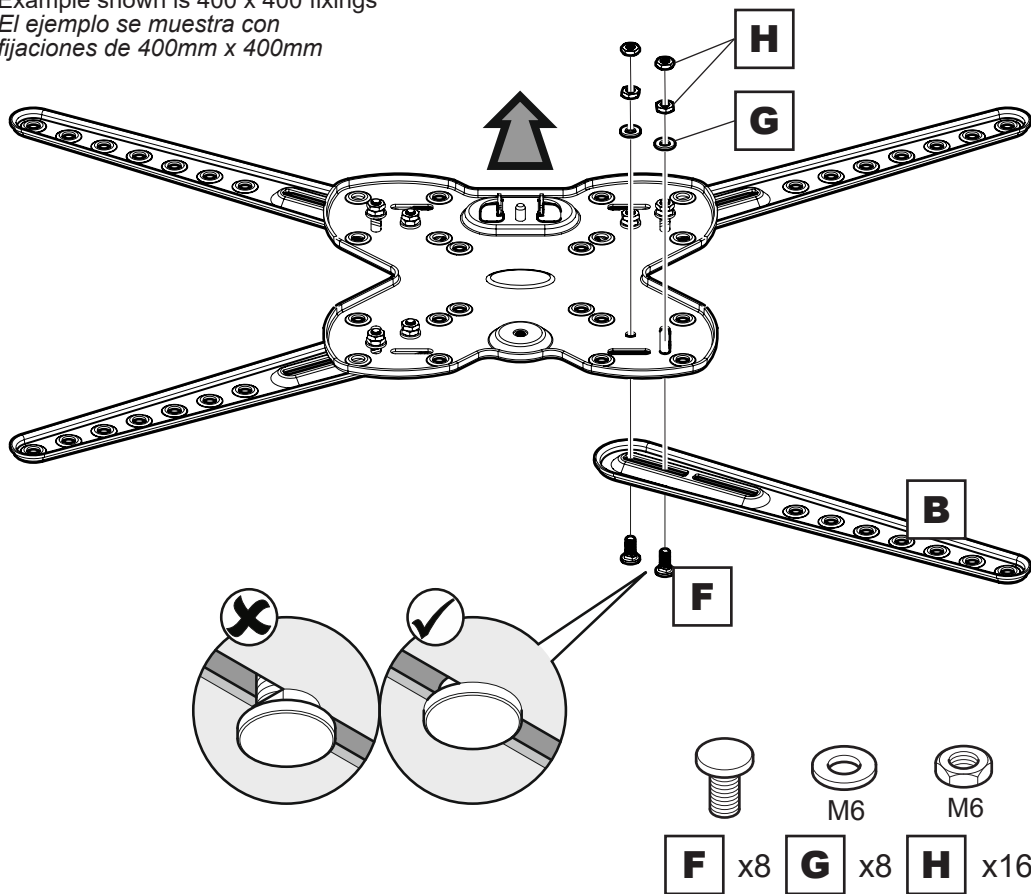

- Holes / Orificios
- Slots / Ranuras

Adaptors **B** can be fixed in different positions in the slots on the plate to match your TV fixing holes.  
 Los adaptadores **B** pueden fijarse en diferentes posiciones en las ranuras de la placa para que coincidan con los orificios de fijación de su televisor.

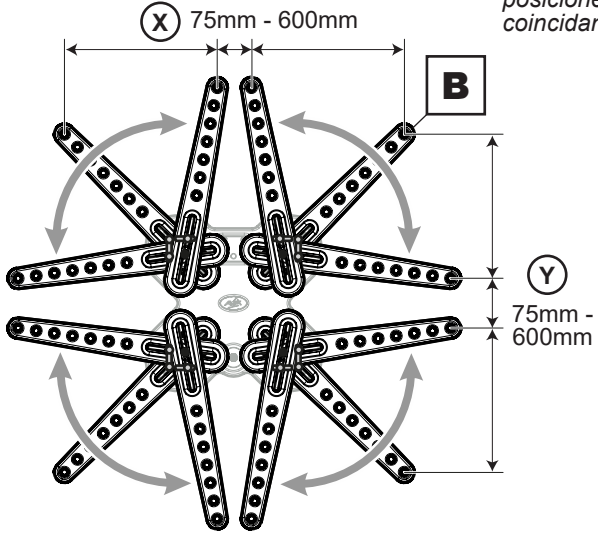

Below are some common examples of how the adaptors can be positioned to match the fixing holes on your TV.  
 A continuación, algunos ejemplos comunes sobre cómo posicionar los adaptadores de manera que concuerden con los orificios de fijación en su TV.

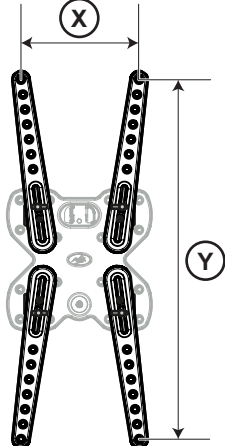
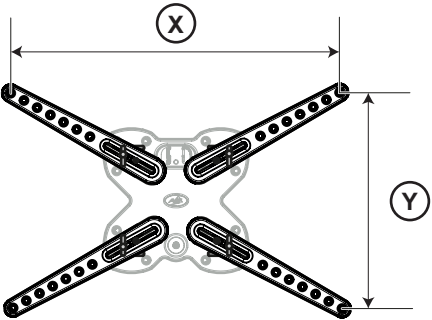
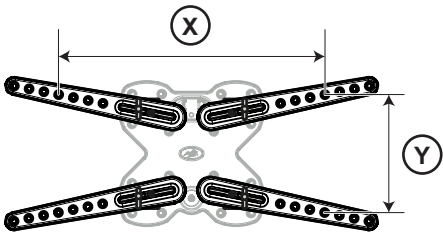
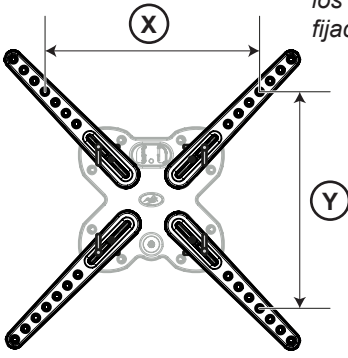

# 3

## Fitting the TV Mounting Plate Fijando La Placa De Montaje De TV

### No Spacers Sin espaciadores

For TVs with flat / unobstructed back  
Para TVs con la parte posterior plana / sin obstáculos

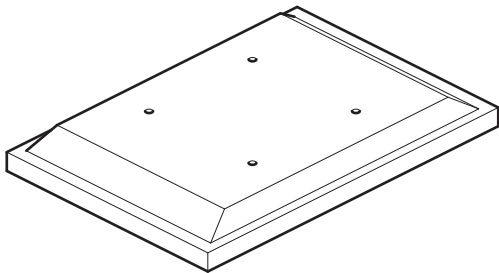

### Spacers Espaciadores

**J1/J2**

For TVs with irregular / obstructed back  
Para TVs con la parte posterior irregular / con obstáculos

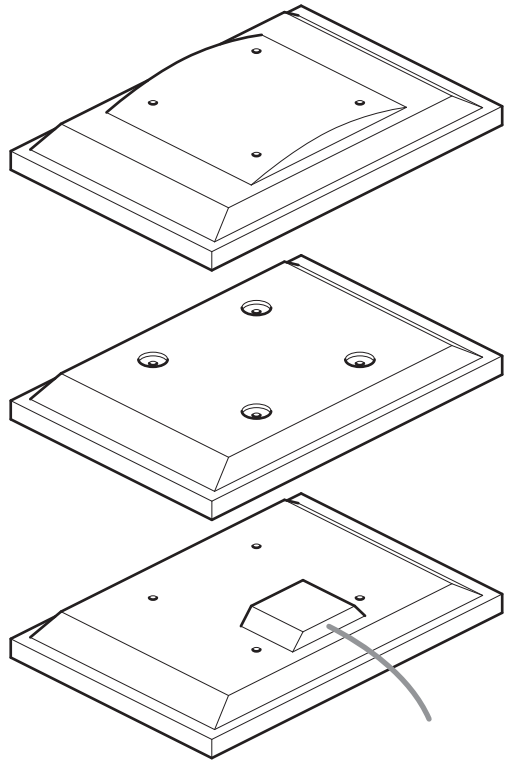

### WARNING / ADVERTENCIA

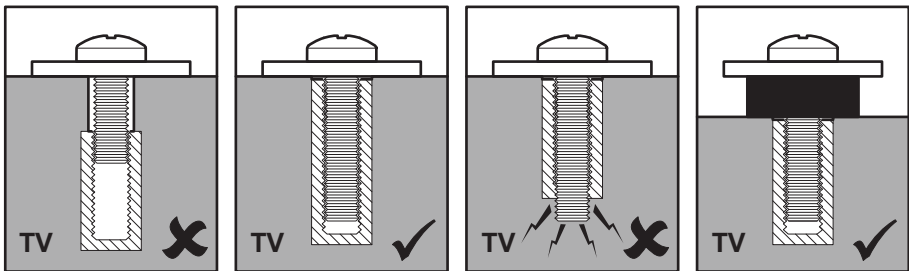

If your TV has an irregular/obstructed back or if you have any issues fitting to the back of your TV with the supplied screws, please call the customer services helpline.

Si la parte posterior de su TV es irregular o está obstruida o si tiene algún problema para fijar la parte posterior de su TV con los tornillos suministrados, comuníquese con la línea de asistencia al cliente.

Before you fully tighten the TV mounting plate please check that the mounting plate holes line up with the fixing holes on the back of your TV.

Antes de fijar completamente la placa de montaje de TV verifique que los orificios de la placa de montaje coincidan con los orificios en la parte posterior de su TV.

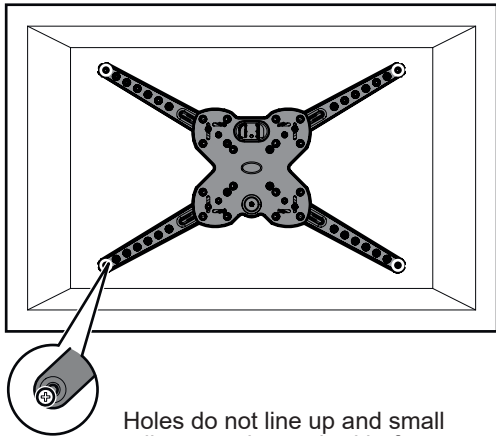

Holes do not line up and small adjustment is required before you fully tighten  
 Los orificios no coinciden y es necesario hacer un pequeño ajuste antes de fijar completamente

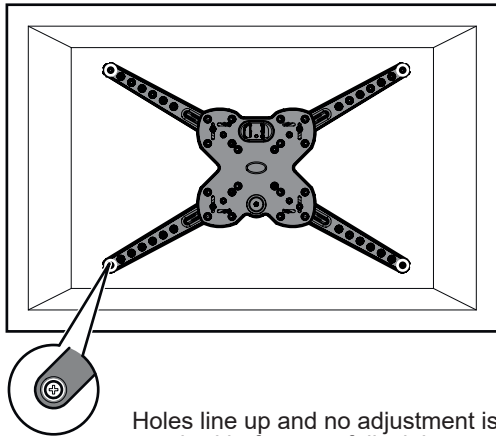

Holes line up and no adjustment is required before you fully tighten  
 Los orificios coinciden y no es necesario hacer ningún ajuste antes de fijar completamente

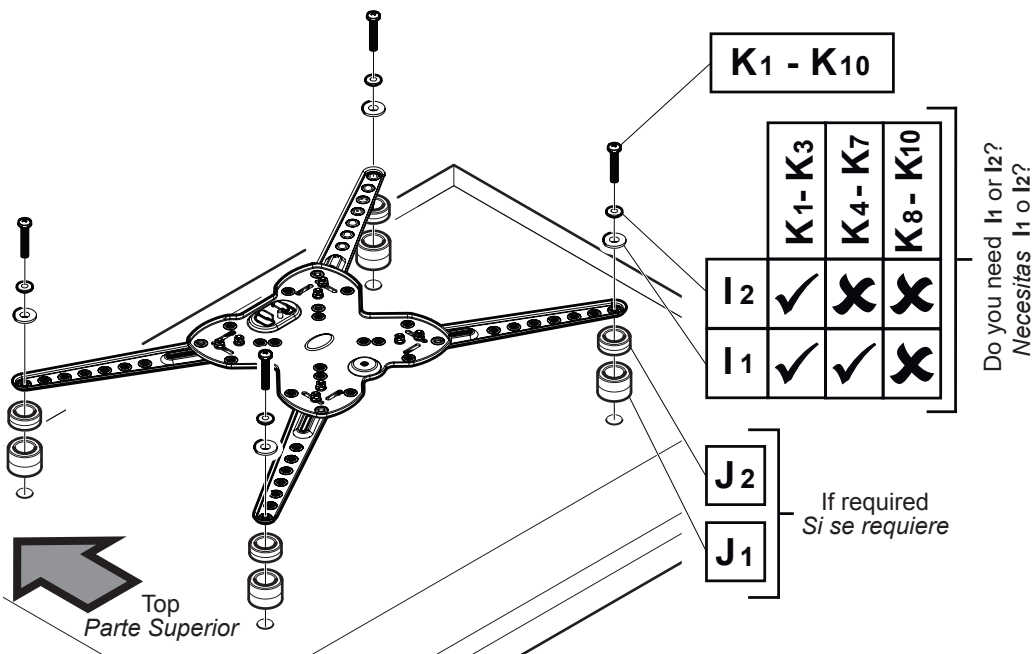

Attach the bracket to the back of your TV using suitable screw, reducer and spacer combinations.  
 Coloque los soportes a la parte posterior de su TV usando la combinación adecuada de tornillo, reductor y espaciador.



## 4 Determine your TV position Determine la posición de su TV



For this step you will need your Wall Drilling Template **WT**.  
*En este paso necesitará utilizar la Plantilla de perforación para pared **WT**.*

Before marking any drill points you will need to determine the wall type that you have, either **Solid Wall** or **Wood Stud Wall**. Ensure the drilling area is free from mains services (Gas / Electric / Water). If fixing to a solid wall it is recommended that you place the drilling template so that the Wall Bracket Centre line is where you want the centre of your TV to be. If you need to avoid services embedded in the wall then you may need to laterally shift the arms on the wall bracket a small amount. See Lateral Shift Option.

If fixing to a wood stud wall you must place the drilling template so that the drilling holes are over two wood studs. If you want the centre of your TV in a different position to the Wall Bracket Centre Line you can laterally shift the arms on the wall bracket to ensure your TV is in the desired position. See Lateral Shift Option.

*Antes de marcar los puntos a perforar, deberá determinar el tipo de pared que tiene, que puede ser sólida o de estructura de madera. Verifique que por el área a perforar no pasen líneas de servicios (gas, electricidad, agua).*

*Si perforará sobre una pared sólida, se recomienda que coloque la plantilla de perforación de manera que la línea central del soporte de pared se encuentre en la parte central donde desea instalar su TV. Si pasan líneas de servicio por esa pared, deberá desplazar de forma lateral los brazos del soporte de pared levemente. Consulte la opción de instalación con desplazamiento lateral.*

*Si la instalación es sobre una pared con estructura de madera, debe colocar la plantilla de perforación de manera que los orificios de perforación queden sobre dos montantes de madera. Si desea que el centro de su TV quede en una posición diferente a la línea central del soporte de pared, puede desplazar lateralmente los brazos del soporte de pared para que su TV quede en la posición deseada. Consulte la opción de instalación con desplazamiento lateral.*



Decide where you want your TV to go on the wall. Measure from the floor to the bottom of where your TV will be. Make a note of this distance in box **d1** on your drilling template.  
*Determine dónde desea ubicar su TV en la pared. Mida desde el piso hasta la parte inferior donde quedará su TV. Tome nota de esta distancia en la casilla **d1** de la plantilla de perforación.*

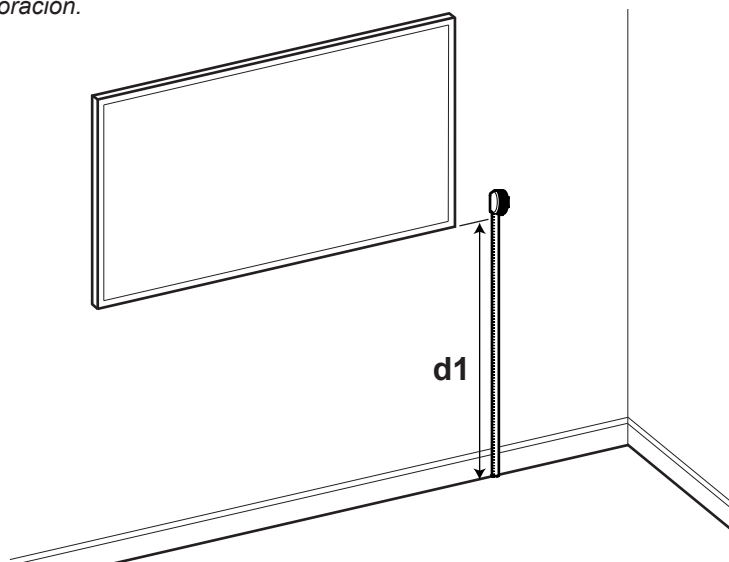

ii

Measure from the top of the TV mounting plate to the bottom of your TV. Make a note of this distance in box **d2** on your drilling template. Add **d1** and **d2** together and put the result in box **d3** on your drilling template.

*Mida desde la parte superior de la placa de montaje de TV hasta la parte inferior de su TV. Tome nota de esta distancia en la casilla **d2** de la plantilla de perforación. Sume la distancia **d1** y **d2** y escriba el resultado en la casilla **d3** de la plantilla de perforación.*

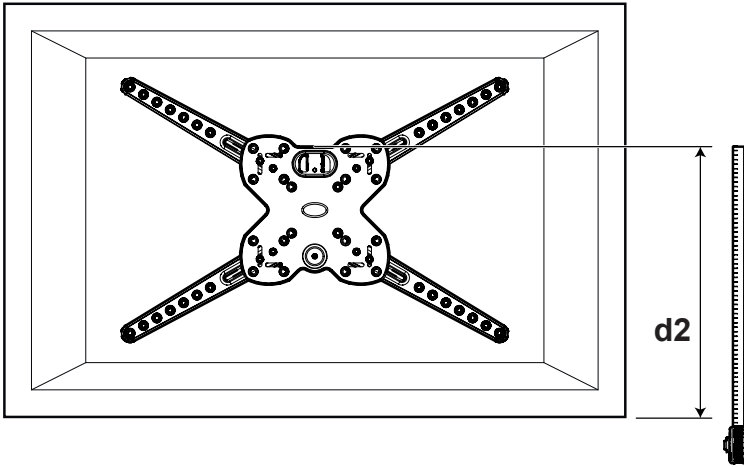

iii

To ensure your TV is at the desired height place the drilling template on the wall so that the Height Measurement line is **d3** above the floor.

*Para asegurarse de que su TV esté a la altura deseada, coloque la plantilla de perforación sobre la pared de manera que la línea de medición de altura esté a "**d3**" del suelo.*

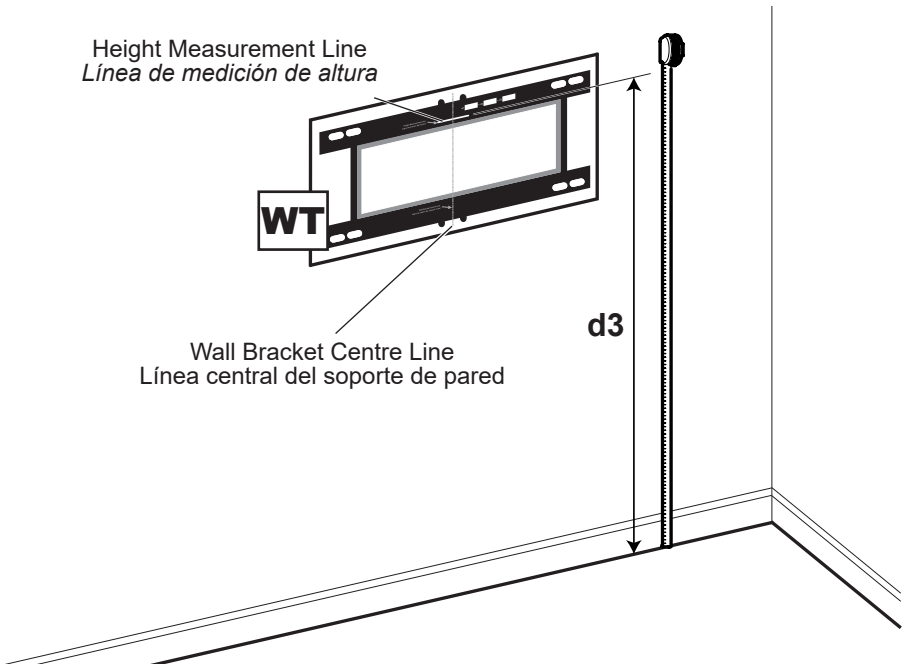

## Lateral Shift (Optional) *Desplazamiento lateral (opcional)*



It is highly recommended that any lateral shift adjustment is done before installing the bracket on the wall.  
*Es muy recomendable ajustar el desplazamiento lateral antes de instalar el soporte sobre la pared.*

The position you have chosen for your TV might not be central between the wood studs, or you may have to avoid services in the wall. In this case you can laterally shift the arms of the bracket so the TV is exactly where you want it.

*La posición que eligió para su TV quizás no quede centrada entre los montantes de madera o quizás deba evitar interferir con los servicios en la pared. En ese caso, puede desplazar lateralmente los brazos del soporte para que su TV quede exactamente donde desea.*

### Example of Lateral Shift *Ejemplo de desplazamiento lateral*

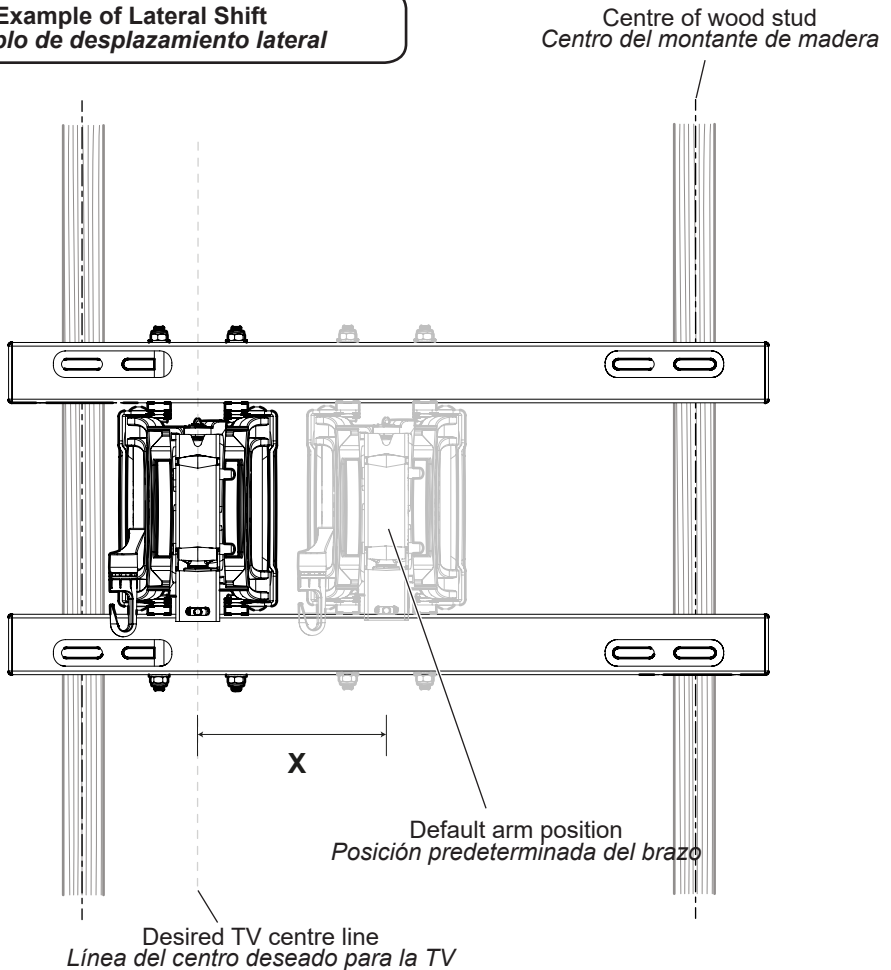

**Lateral Shift Procedure**  
**Procedimiento de desplazamiento lateral**

**i**

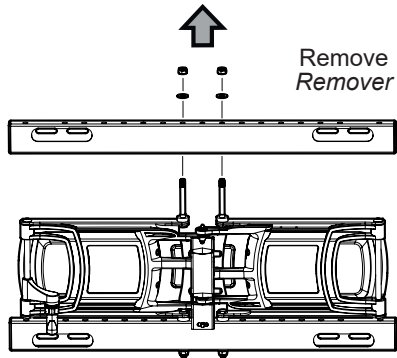

**ii**

Move top bracket across  $x$   
*Mover el brazo superior por  $x$*

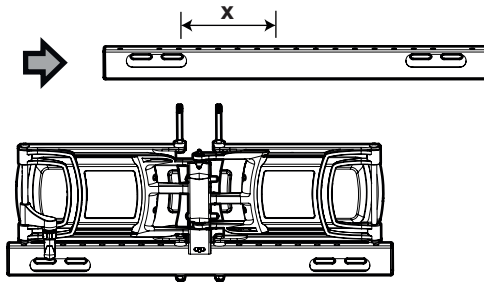

**iii**



DO NOT overtighten  
*No apriete demasiado*

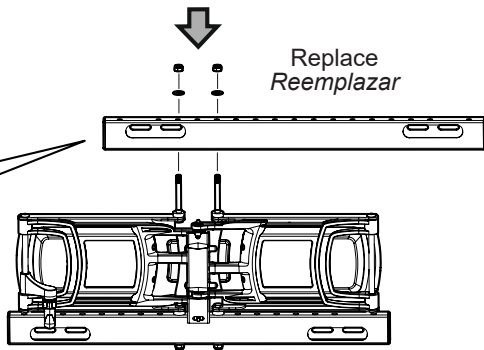
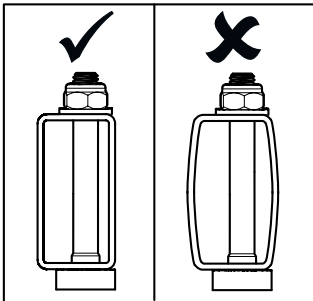

**iv**

Repeat steps i to iii for the bottom bracket.  
*Repetir los pasos i al iii con el brazo inferior.*

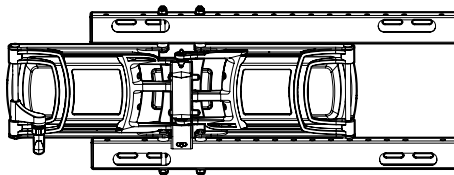

## 5 Marking Wall for Drill Points *Marcar la Pared Para Punto de Taladro*

Before you drill make sure you are happy with the position and ensure template is level.  
*Antes de comenzar a perforar, compruebe que la ubicación sea de su agrado y que la plantilla esté nivelada.*

### Wood Stud *Viga de madera*

Use the slot that is over the center of your wood stud.  
*Use la ranura sobre el centro del montante de madera.*

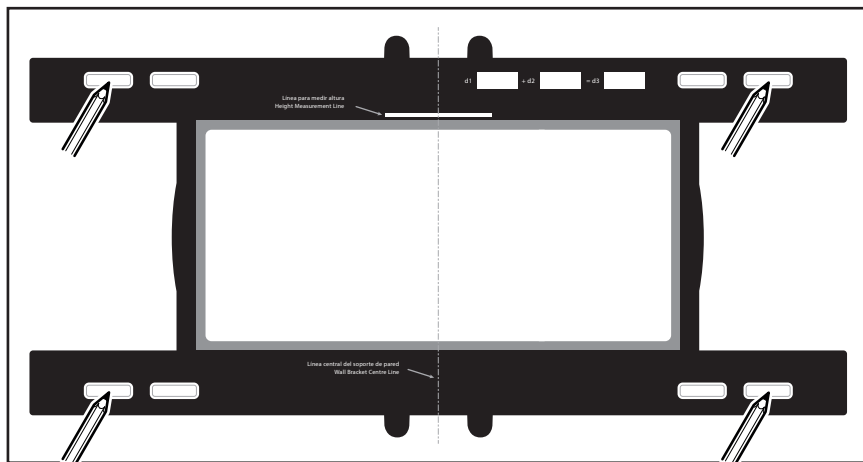

### Solid Wall *Pared sólida*

Use the six slots shown.  
*Use las seis ranuras que se muestran.*

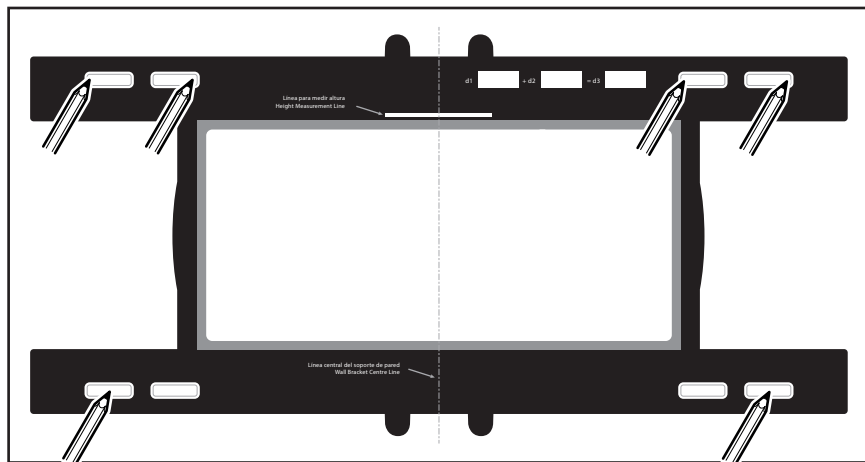

# 6

## Fitting the Wall Bracket Fijando la Placa a la Pared

Solid Wall  
Pared solida

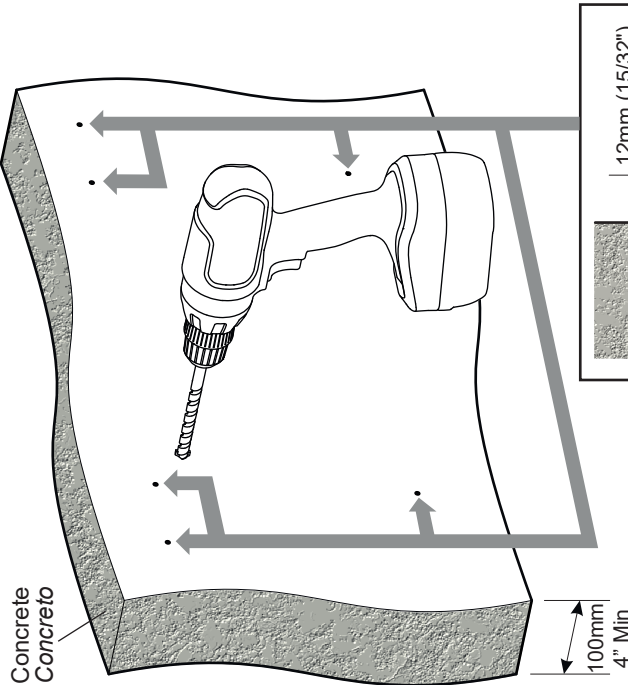

Remove Dust from Hole  
Elimine el polvo del agujero



Wood Stud  
Viga de madera

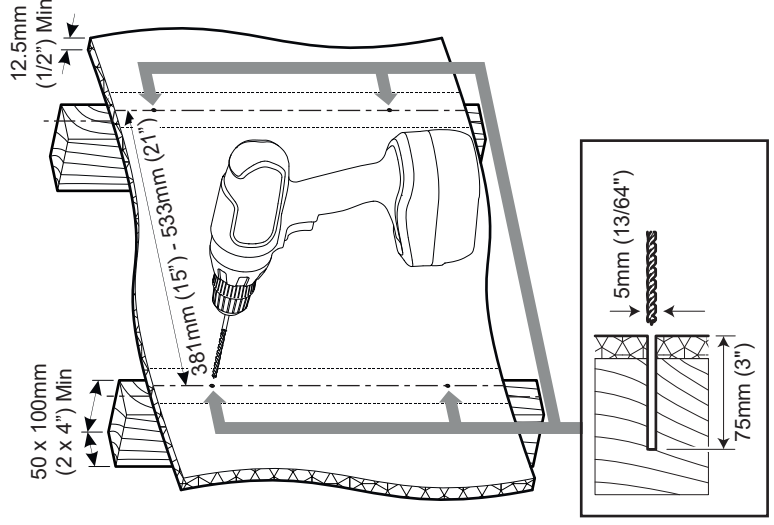

Ensure you drill in the centre of the wood stud  
Asegúrese de perforar en el centro del montante  
de madera



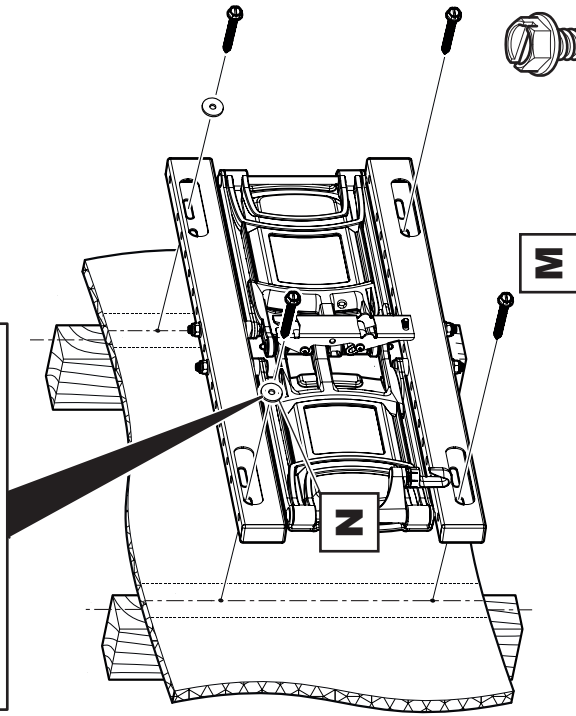

Lubricate screw thread with soap  
*Lubrique la rosca del tornillo con jabón*

DO NOT overtighten  
 screws. Tighten  
 screws by hand only  
 NO sobre apriete los  
 tornillos. Apriete los  
 tornillos sólo a mano



**N** x2  
**M** x4



**M** x6

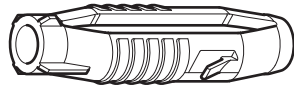

**L** x6

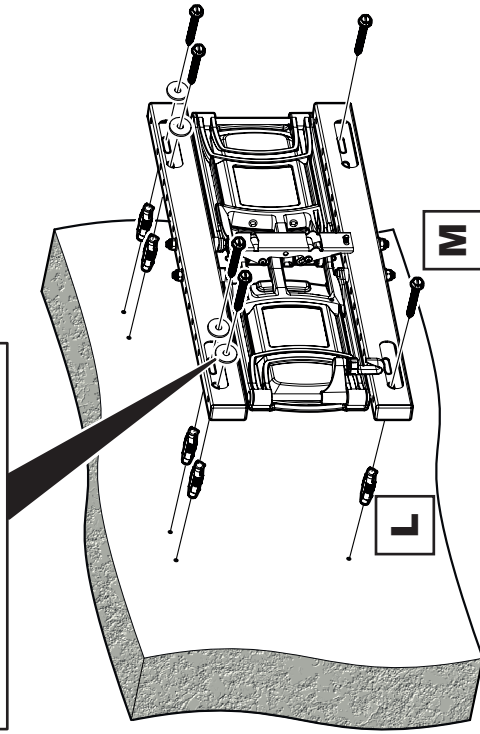
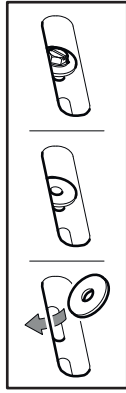

Lubricate screw thread with soap  
*Lubrique la rosca del tornillo con jabón*

DO NOT overtighten  
 screws. Tighten  
 screws by hand only  
 NO sobre apriete los  
 tornillos. Apriete los  
 tornillos sólo a mano



**N** x4



## 7 Fitting the Wall Bracket Covers Fijando Las Cubiertas Del Soporte De Pared

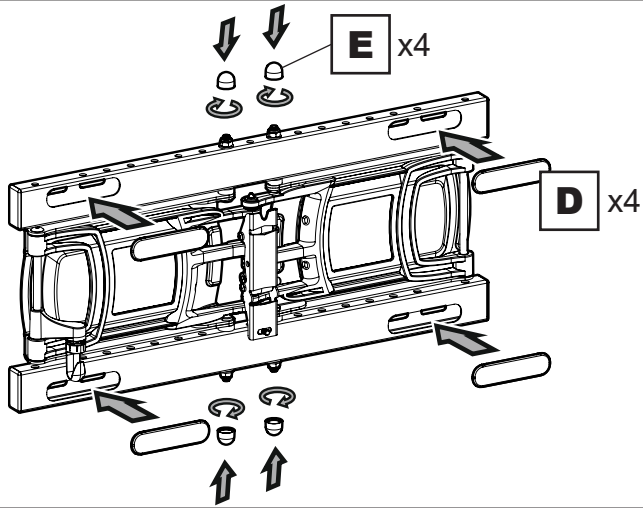

## 8 Connecting the TV Conectando la TV

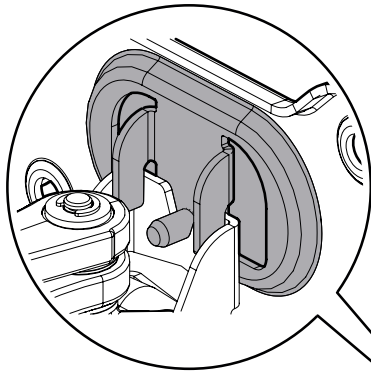

Attaching and Locking  
Sujetando y Asegurando

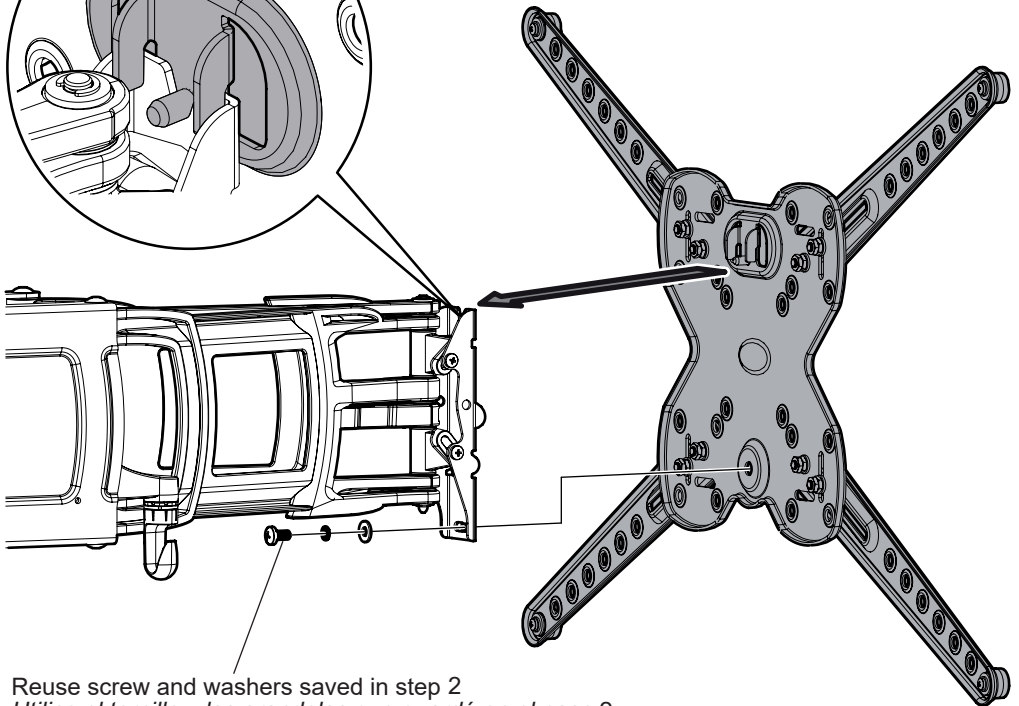

Reuse screw and washers saved in step 2  
Utilice el tornillo y las arandelas que guardó en el paso 2



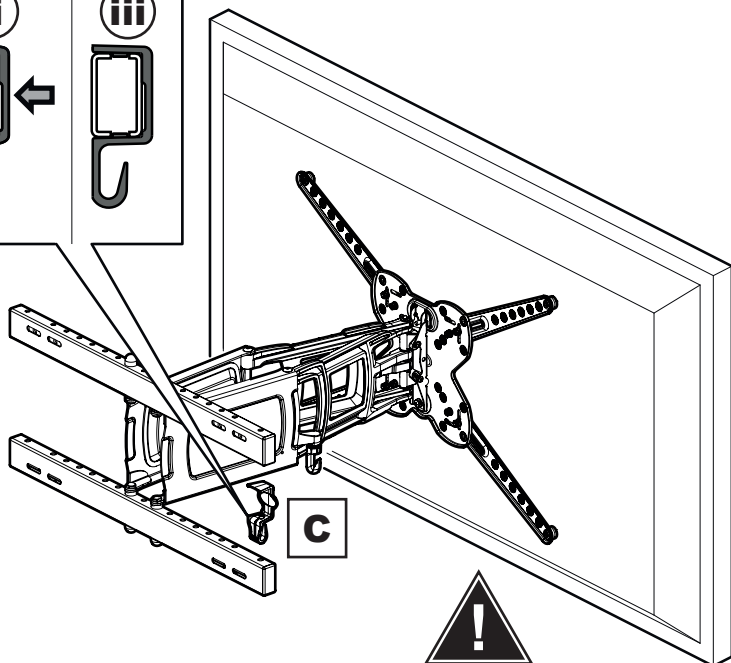
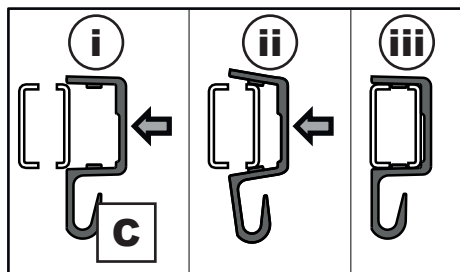

Check all fittings are tight  
*Verifique que todos los elementos  
queden bien ajustados*

Ensure cables don't  
restrict arm movement  
*Asegure que los cables  
no restringen el movimiento  
de los brazos*

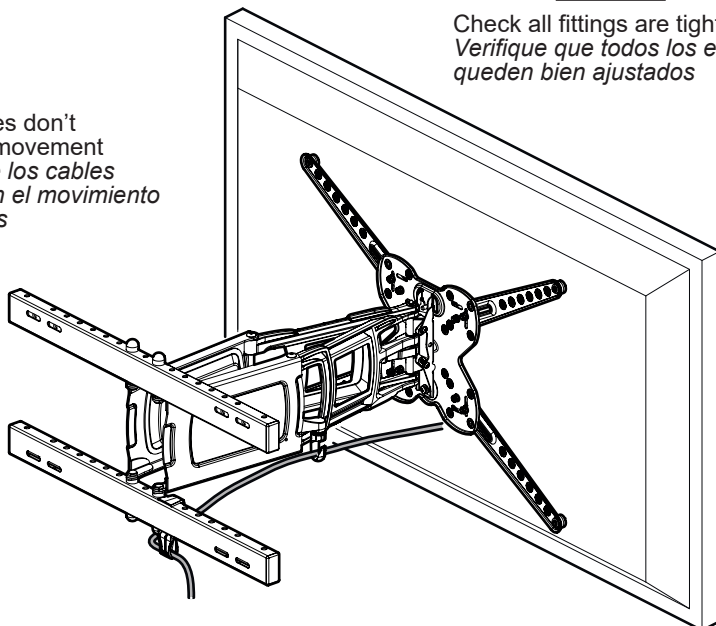

Lock Tilt (optional)  
*Ajuste de inclinación (opcional)*

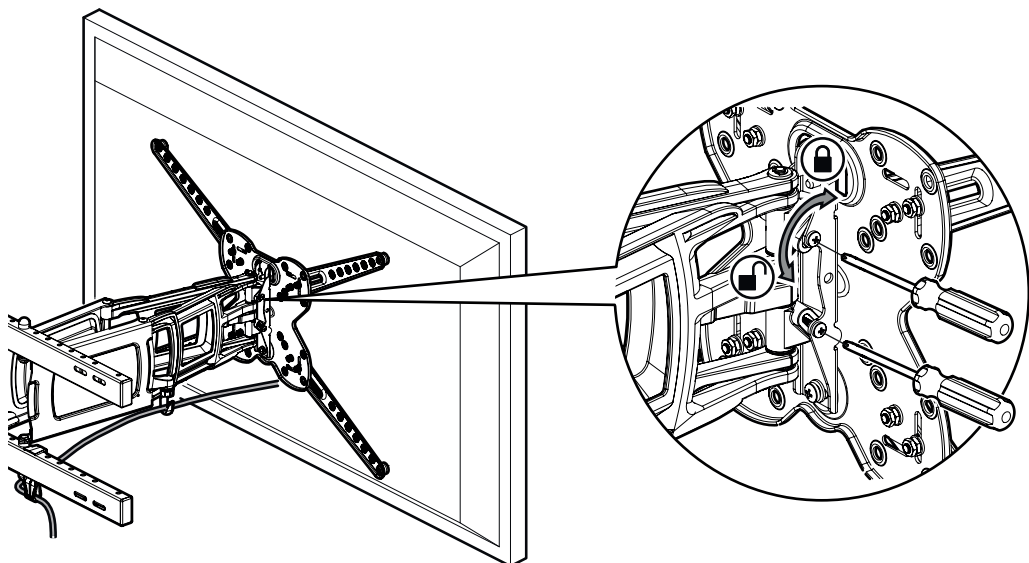

TV Levelling (optional)  
*Nivelación de TV (opcional)*

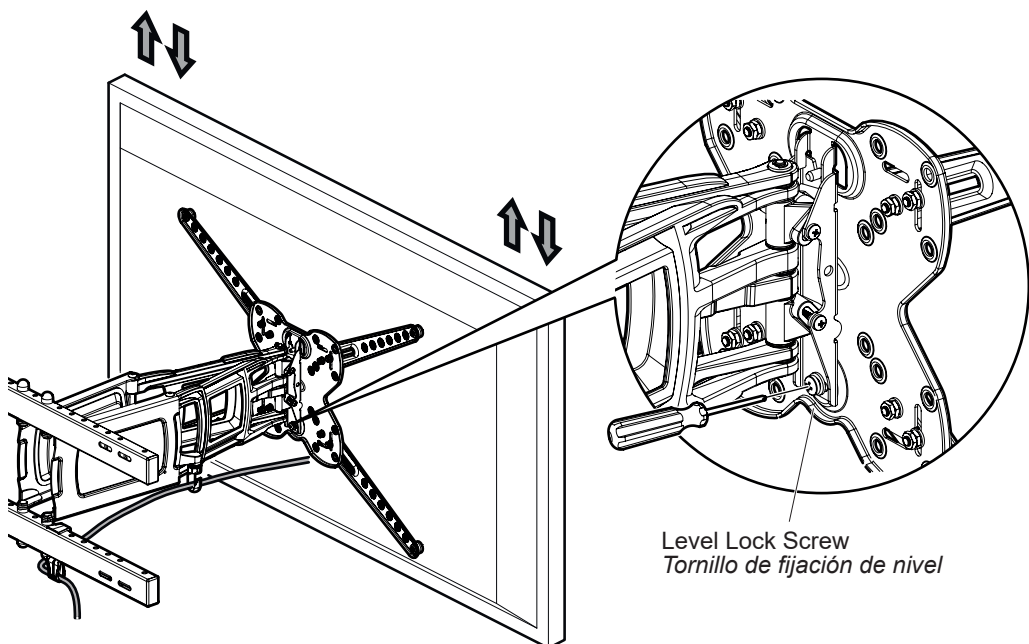

Loosen the Level Lock Screw, adjust your TV until it is level, then re-tighten the screw.  
*Afje el tornillo de fijación de nivel, nivele su TV y vuelva a ajustar el tornillo.*