

www.avfgroup.com

467800 rev00

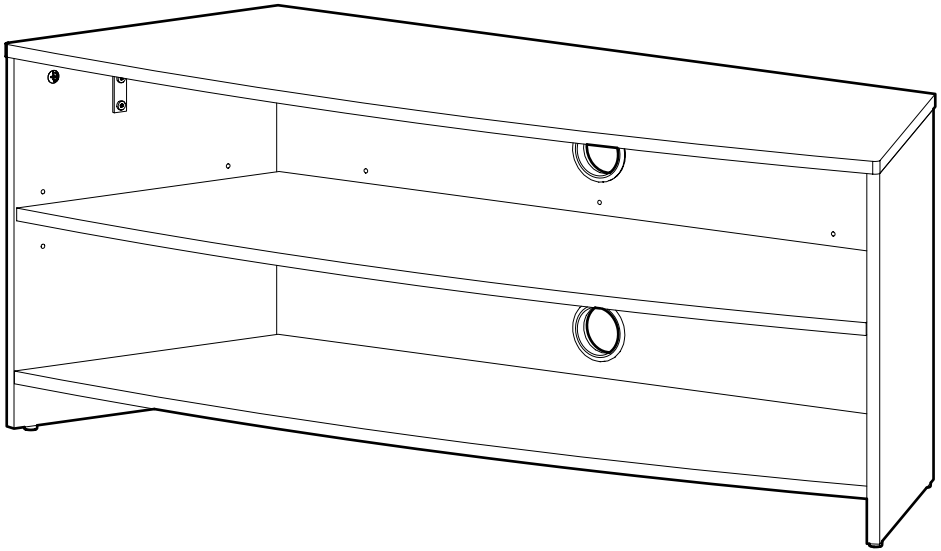

40kg
88lbs

STOP

Read through ALL instructions before commencing installation.

If you have any questions about this product or issues with installation, contact the customer services help line before returning this product to the store.

**ARRETEZ
-VOUS**

Lisez toutes les instructions avant de débiter l'installation.

Si vous avez des questions sur ce produit ou des problèmes d'installation, contactez l'assistance client avant de ramener le produit en magasin.

ALTO

Lea todas las instrucciones antes de comenzar la instalación.

Si tiene alguna pregunta sobre el producto o problemas con la instalación, llame a la línea de servicio al consumidor antes de devolverlo.

CUSTOMER SERVICES HELP LINE NUMBER: **+44 (0) 333 320 0463 (UK)**

NUMÉRO DE L'ASSISTANCE CLIENT:

NUMERO DE SERVICIO DE ATENCION AL CLIENTE: **1-800 667 0808 (USA)**

IMPORTANT INFORMATION!

We advise that before starting the assembly of this product that you familiarise yourself with the instructions and the parts list in this leaflet.

INFORMATIONS IMPORTANTES!

Nous vous recommandons de vous familiariser avec ces instructions et la liste des pièces détachées contenues dans ce document avant de commencer l'assemblage de ce produit.

INFORMACIÓN IMPORTANTE!

Le recomendamos que antes de comenzar el ensamblaje de este producto se familiarize con las instrucciones y la lista de partes en esta hoja informativa.

Do not's

Do not over tighten any part of this assembly.

Do not place hot or cold objects on to or next to any wood surface unless the object is sufficiently insulated to prevent contact.

Do not strike the wood with hard or pointed items.

Do not sit, stand or climb upon any part of this furniture.

Do not use washing powders or other substances containing abrasives when cleaning the wood.

À ne pas faire

Ne serrez pas trop fort aucun des éléments de cet assemblage.

Ne déposez pas d'objets froids ou chauds sur ou près de toute surface en bois, à moins que l'objet soit suffisamment isolé pour éviter le contact.

Ne frappez pas le bois avec des objets durs ou pointus.

Ne pas vous asseoir, vous tenir debout ou grimper sur toute partie de ce meuble.

N'utilisez pas de lessive en poudre ou toute autre substance abrasive pour nettoyer le bois.

No haga

No apriete demasiado ninguna de las piezas de este soporte.

No coloque objetos calientes ni fríos sobre o al lado de cualquier superficie de madera a menos de que el objeto esté suficientemente aislado como para evitar el contacto.

No golpee la madera con objetos duros o puntiagudos.

No se siente ni se pare ni se suba sobre ninguna parte de este mobiliario.

No utilice polvos para lavar ni otras sustancias que contengan abrasivos cuando limpie la madera.

Do's

Do use a soft cloth with a suitable furniture polish when cleaning wooden panels.

À faire

Utilisez un chiffon doux avec un produit adapté pour le nettoyage des meubles afin de nettoyer les panneaux en bois.

Si haga

Use un trapo suave con limpiador o embellecedor de muebles cuando limpie pánels de madera.

Maximum TV weight and shelf capacities

Poids maximal du téléviseur et capacité de charge de l'étagère

Máximo peso y capacidad del estante de TV

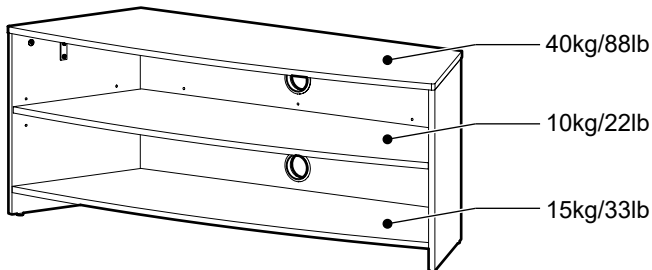

WARNING: Wherever possible distribute weight evenly.

AVERTISSEMENT: Répartissez le poids de manière uniforme lorsque cela est possible.

ADVERTENCIA: En la medida de lo posible distribuya el peso uniformemente.

Boxed Parts
Pièces empaquetées
 Piezas en la Caja

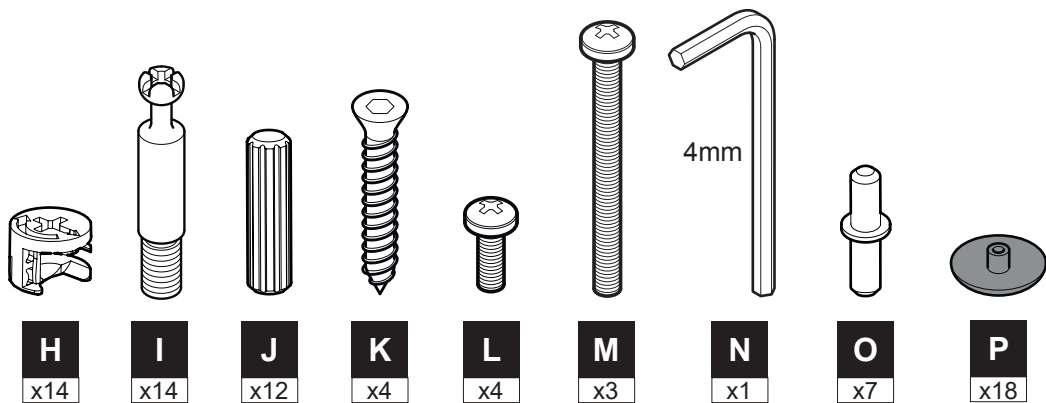
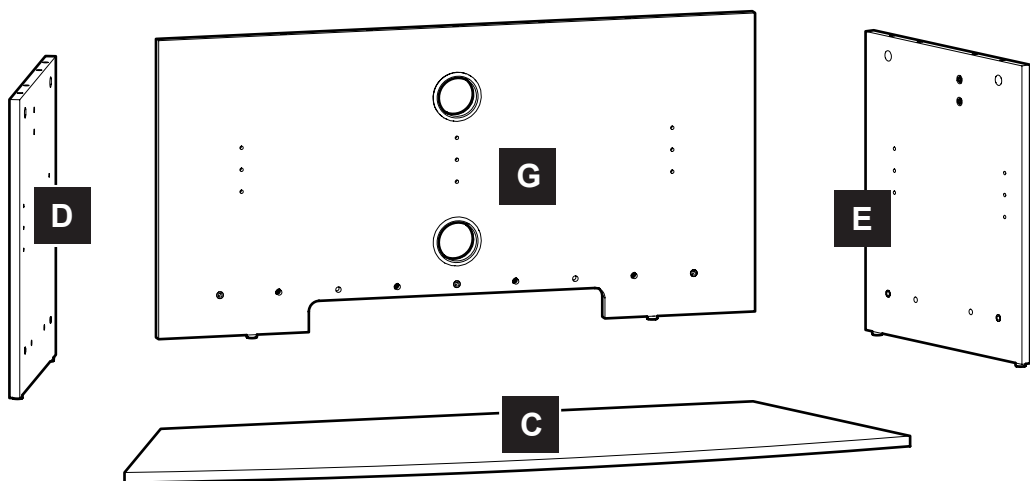
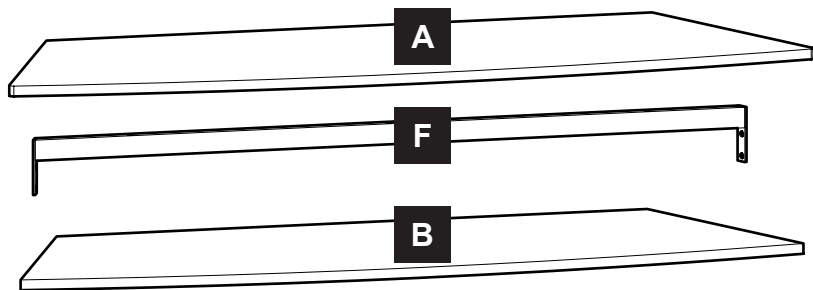

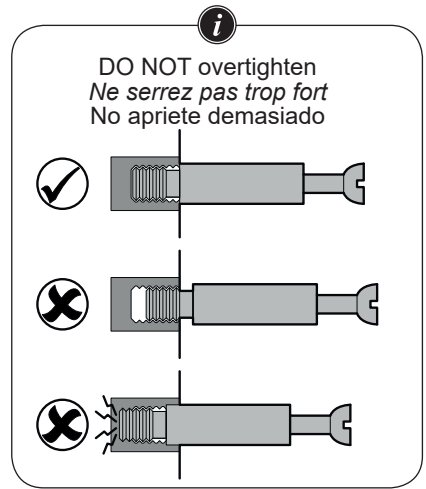
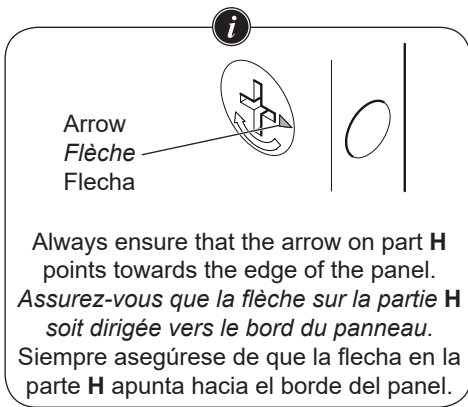

Put a piece of material underneath the panels to prevent damage.
Placez un morceau de tissu sous les panneaux pour prévenir des dommages.
Coloque un pedazo del material debajo de los paneles para evitar cualquier daño.

1

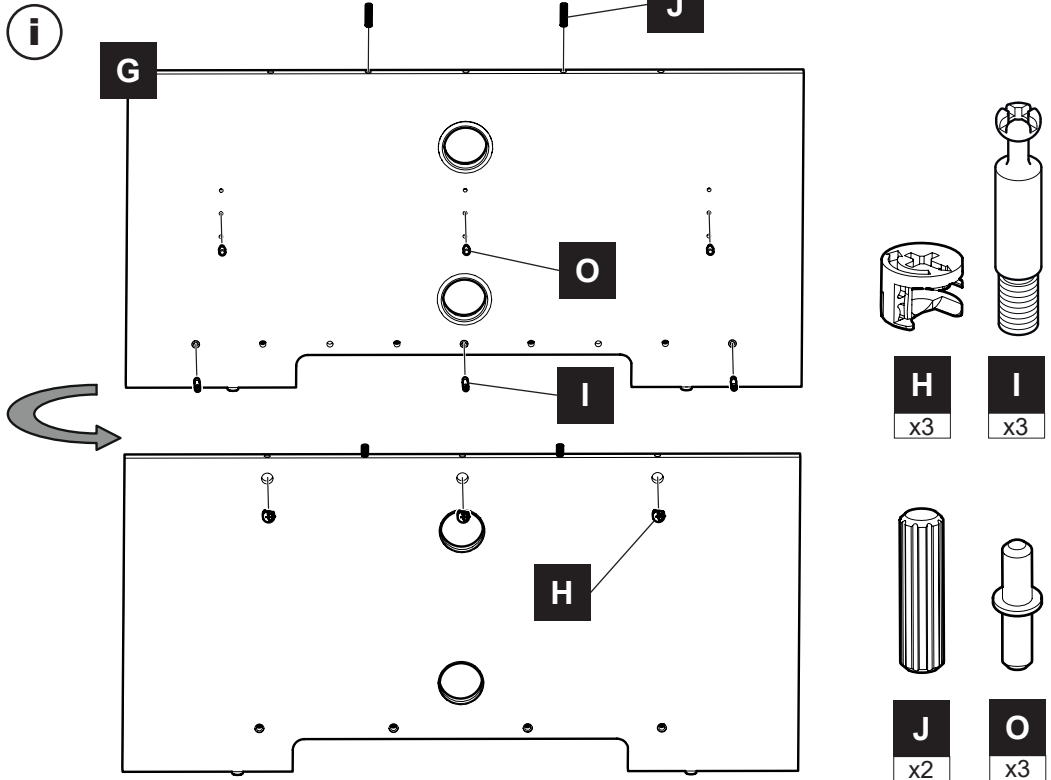

ii

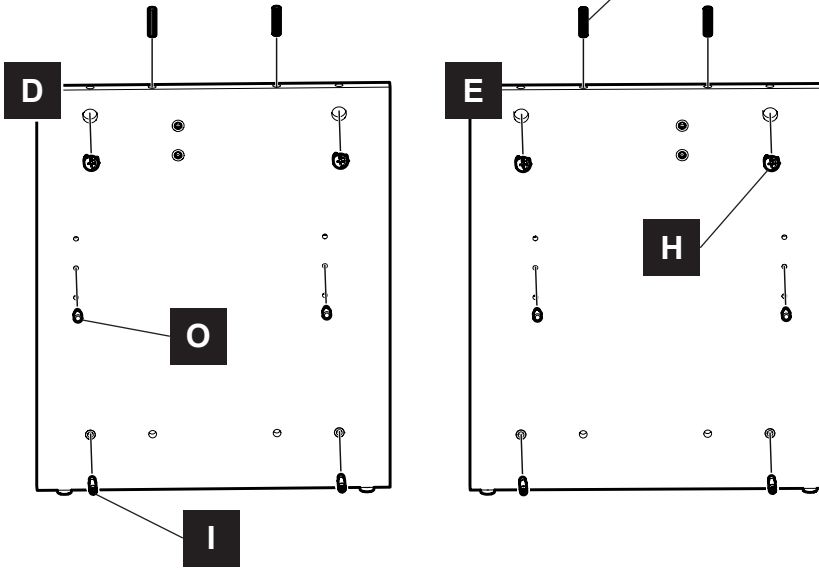

H
x4



I
x4

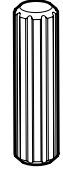

J
x4

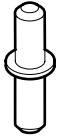

O
x4

iii

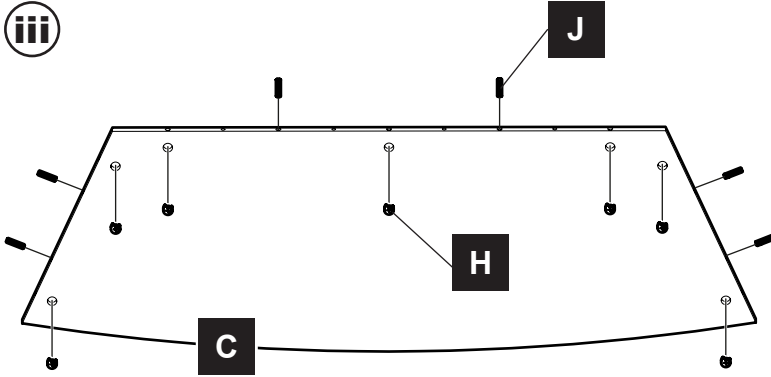

H
x7

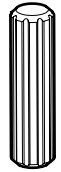

J
x6

iv

i
DO NOT fully tighten
Ne serrez pas à fond
No ajuste completamente

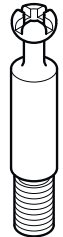
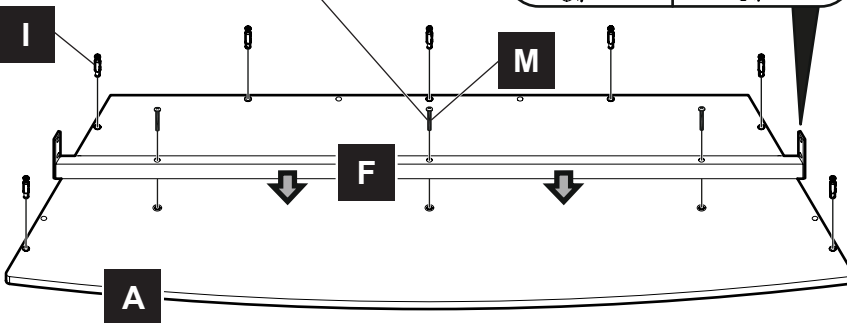
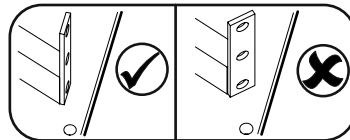

I
x7

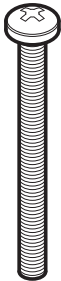

M
x3

2

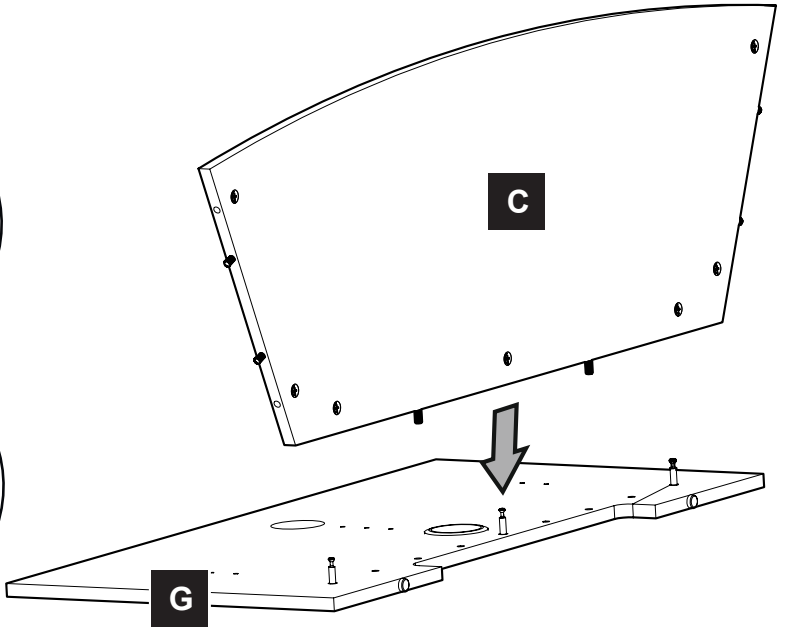
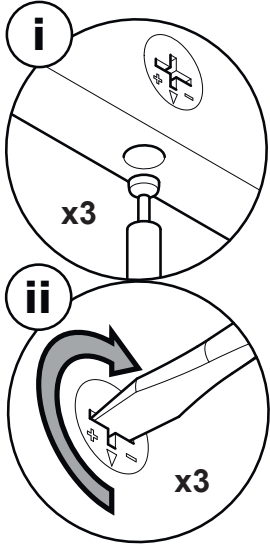

3

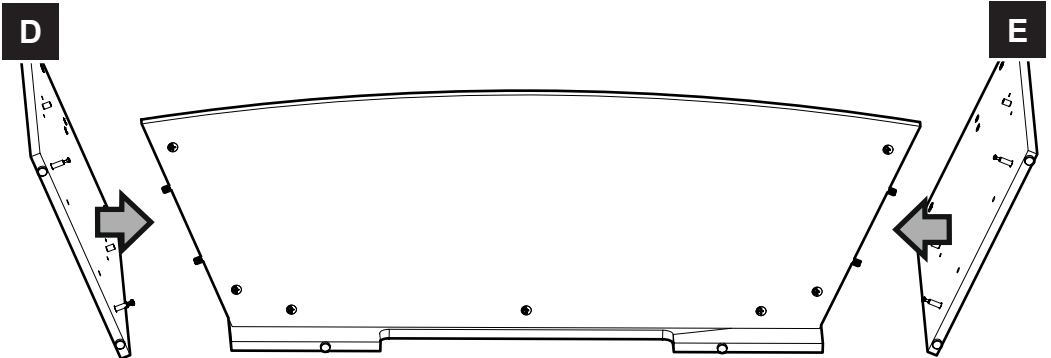
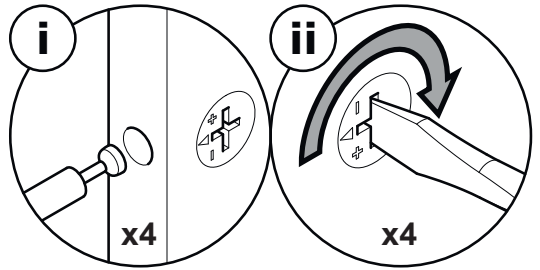

4

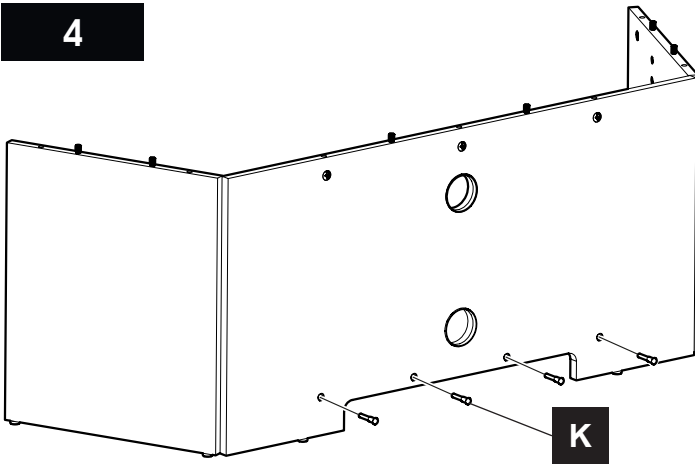

DO NOT overtighten
 Ne serrez pas trop fort
 No apriete demasiado



K
 x4

5

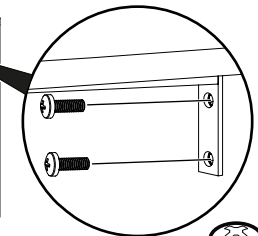
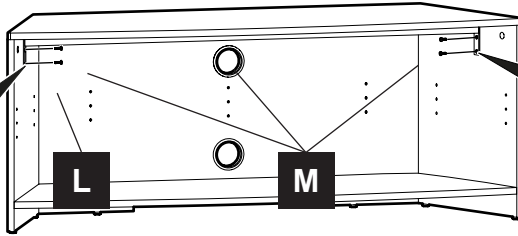
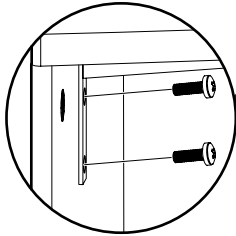
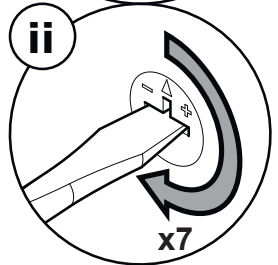
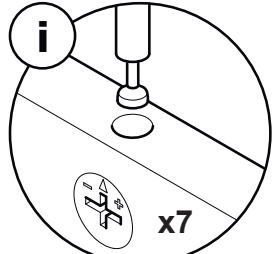
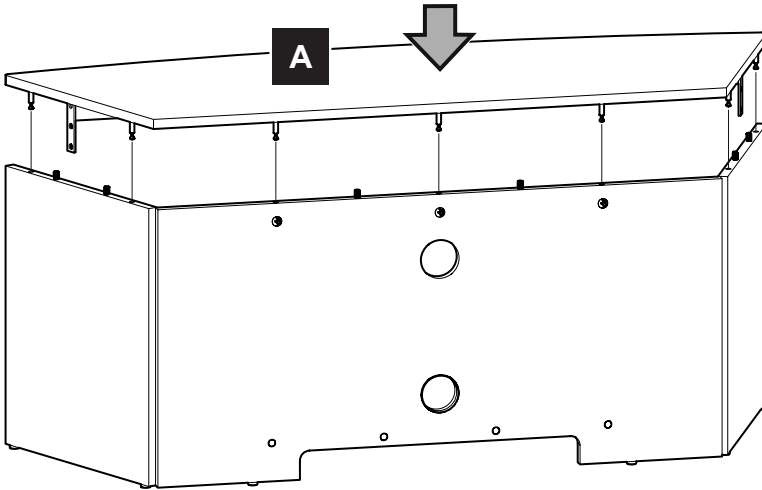

Fully tighten
 Serrez complètement
 Ajustar completamente

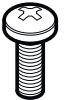

L
 x4

6

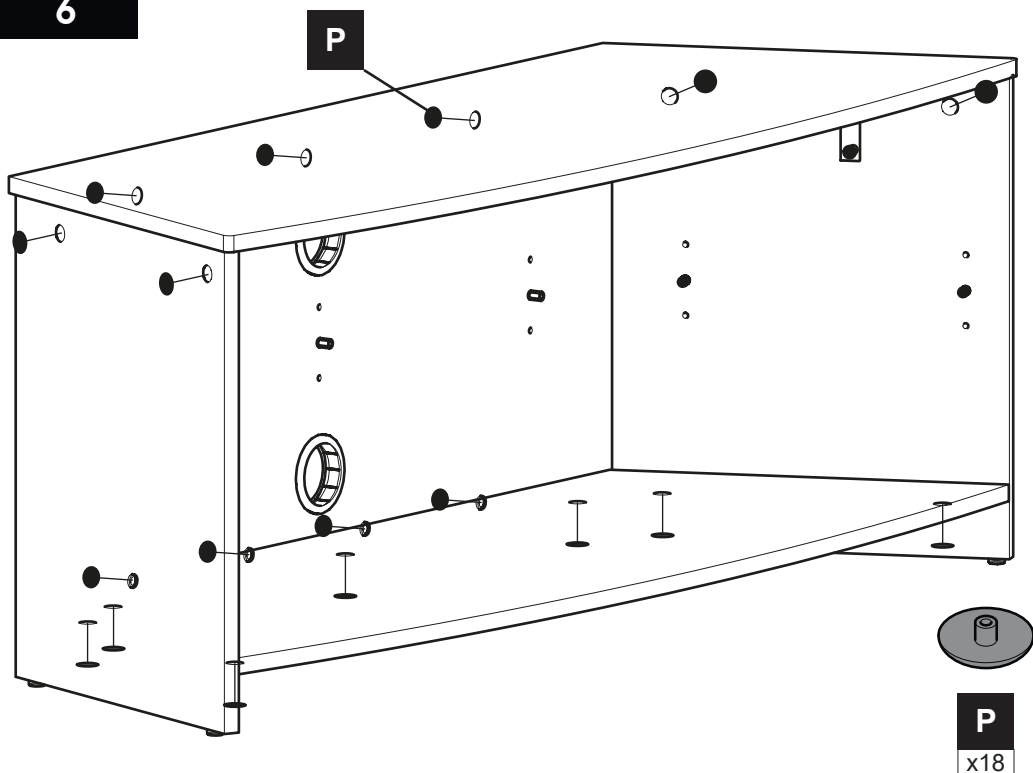

7

