

PLUS

www.avfgroup.com

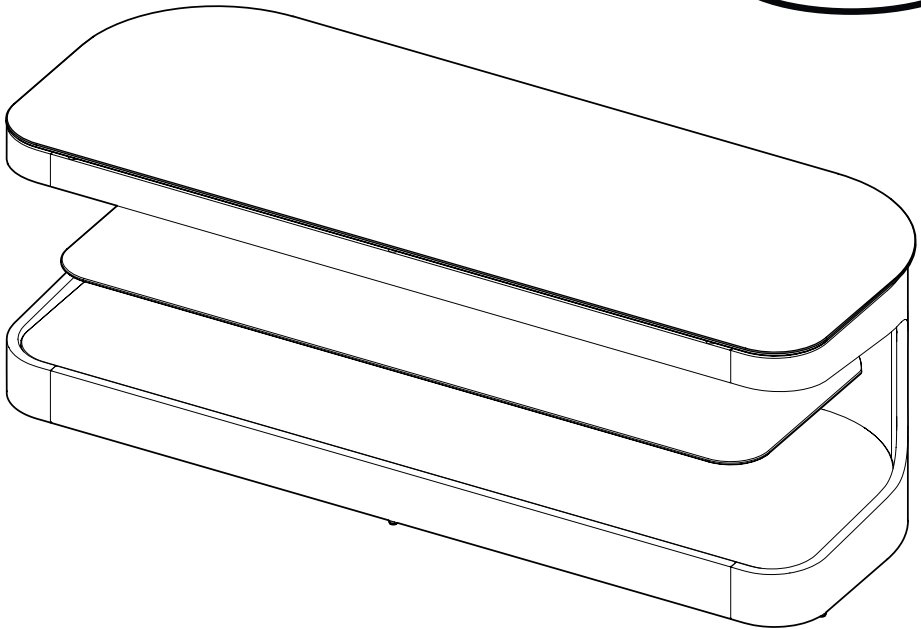

Read through ALL instructions before commencing installation.

If you have any questions about this product or issues with installation, contact the customer services help line before returning this product to the store.



Lisez toutes les instructions avant de débiter l'installation.

Si vous avez des questions sur ce produit ou des problèmes d'installation, contactez l'assistance client avant de ramener le produit en magasin.



Lea todas las instrucciones antes de comenzar la instalación.

Si tiene alguna pregunta sobre el producto o problemas con la instalación, llame a la línea de servicio al consumidor antes de devolverlo.

CUSTOMER SERVICES HELP LINE NUMBER: **+44 (0) 333 320 0463 (UK)**
 NUMÉRO DE L'ASSISTANCE CLIENT: **1-800 667 0808 (USA)**
 NUMERO DE SERVICIO DE ATENCION AL CLIENTE: **1-800 667 0808 (USA)**

IMPORTANT INFORMATION!

We advise that before starting the assembly of this product that you familiarise yourself with the instructions and the parts list in this leaflet.

INFORMATIONS IMPORTANTES!

Nous vous recommandons de vous familiariser avec ces instructions et la liste des pièces détachées contenues dans ce document avant de commencer l'assemblage de ce produit.

INFORMACIÓN IMPORTANTE!

Le recomendamos que antes de comenzar el ensamblaje de este producto se familiarize con las instrucciones y la lista de partes en esta hoja informativa.

Do not's

Do not over tighten any part of this assembly.

Do not place hot or cold objects on to or close next to any glass surface unless the object is sufficiently insulated to prevent contact.

Do not strike the glass with hard or pointed items.

Do not sit or stand upon horizontal glass surfaces.

Do not use washing powders or other substances containing abrasives when cleaning the glass.

À ne pas faire

Ne serrez pas trop fort aucun des éléments de cet assemblage.

Ne placez aucun objet froid ou chaud sur ou à proximité de toute surface en verre à moins que celui-ci ne présente une isolation suffisante pour empêcher tout contact.

Ne frappez pas les surfaces en verre avec des objets lourds ou pointus.

Ne vous asseyez ni ne montez pas sur les surfaces horizontales en verre.

N'utilisez pas de poudre à récurer ou toute autre substance abrasive lorsque vous nettoierez les surfaces en verre car cela risquerait de provoquer des rayures.

No haga

No apriete demasiado ninguna de las piezas de este soporte.

No coloque objetos calientes o fríos en o cerca de cualquier superficie de vidrio, a menos que el objeto esté aislado para prevenir contacto directo.

No golpee el vidrio con artículos fuertes o punzantes.

No se sienta o se pare en superficies de vidrio.

No use detergentes para lavar u otras sustancias que contengan abrasivos cuando esté limpiando el vidrio ya que estas pueden rayarlo.

Do's

Do use a damp cloth with diluted washing up liquid for cleaning the glass surfaces.

Check all nuts and bolts from time to time.

À faire

Utilisez un chiffon humide imprégné de liquide vaisselle dilué pour le nettoyage des surfaces en verre.

Vérifiez tous les écrous et les boulons de temps à autre.

Si haga

Use un trapo suave con líquido diluido en agua para limpiar las superficies de vidrio.

Compruebe todos los tornillos y tuercas de vez en cuando.

Maximum TV weight and shelf capacities

Poids maximal du téléviseur et capacité de charge de l'étagère

Máximo peso y capacidad del estante de TV

With optional FL602KIT

Avec FL602KIT optionnel

Con FL602KIT opcional

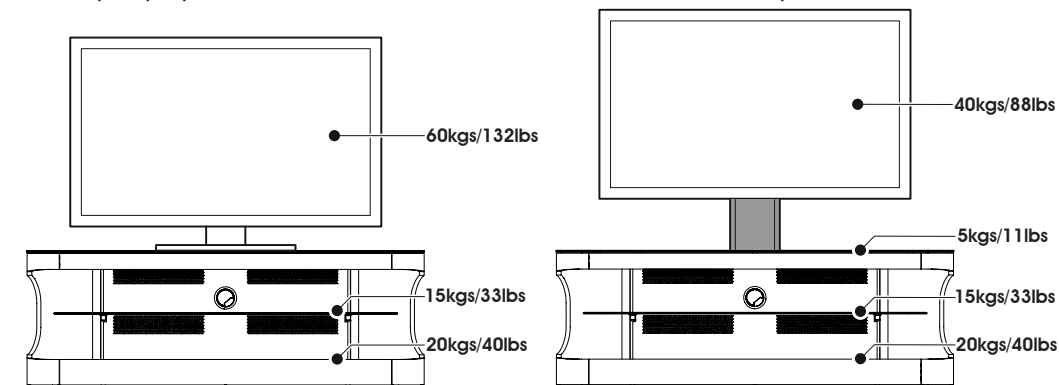

WARNING: Wherever possible distribute weight evenly.

AVERTISSEMENT: Répartissez le poids de manière uniforme lorsque cela est possible.

ADVERTENCIA: En la medida de lo posible distribuya el peso uniformemente.

Boxed Parts
Pièces empaquetées
Piezas en la Caja

Tools Recommended
Outils recommandés
Herramientas recomendadas

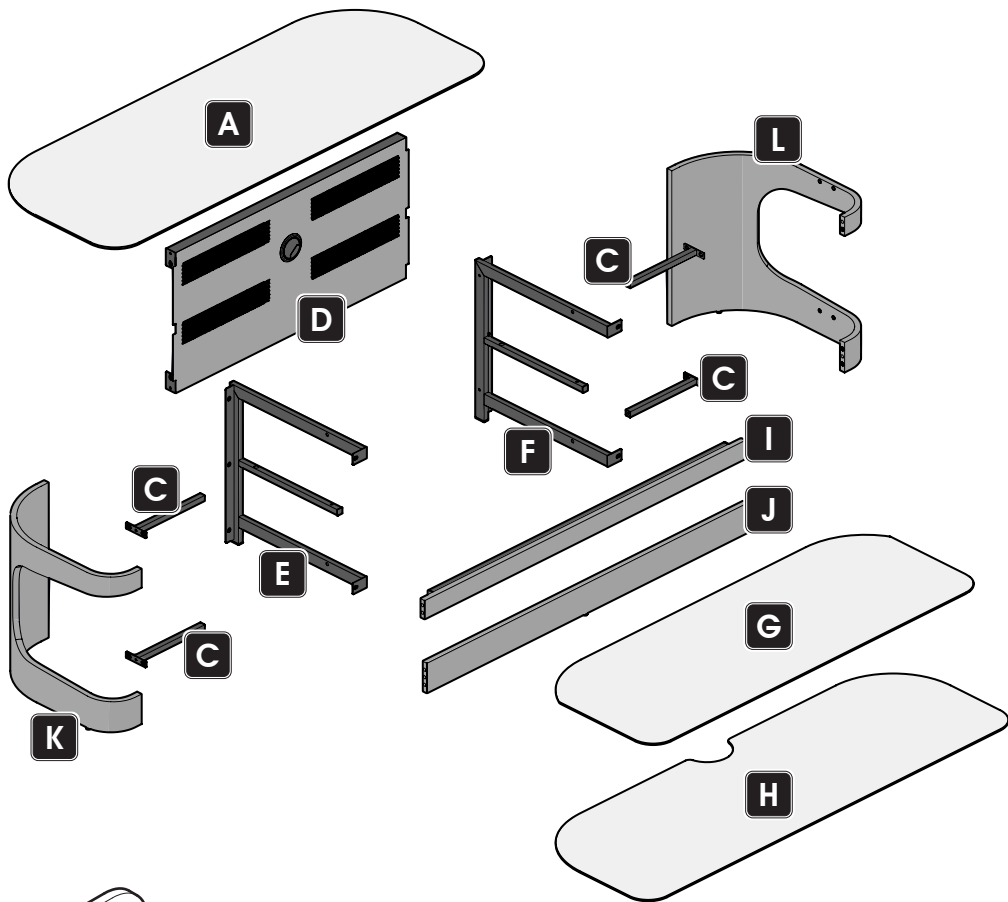
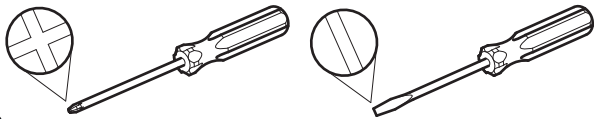

M
X1

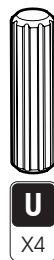
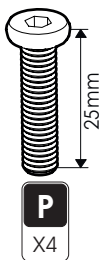
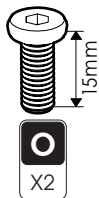
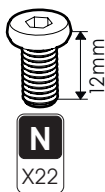

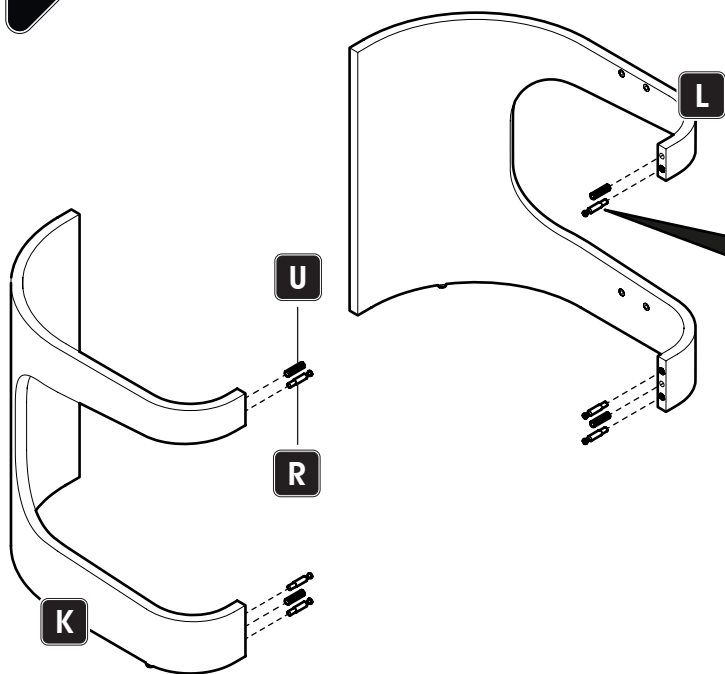
1

i
DO NOT overtighten
Ne serrez pas trop fort
No apriete demasiado

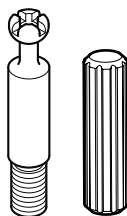
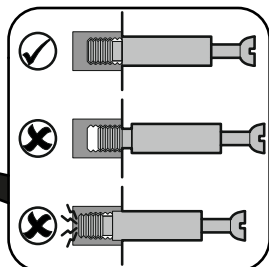

R
X6

U
X4

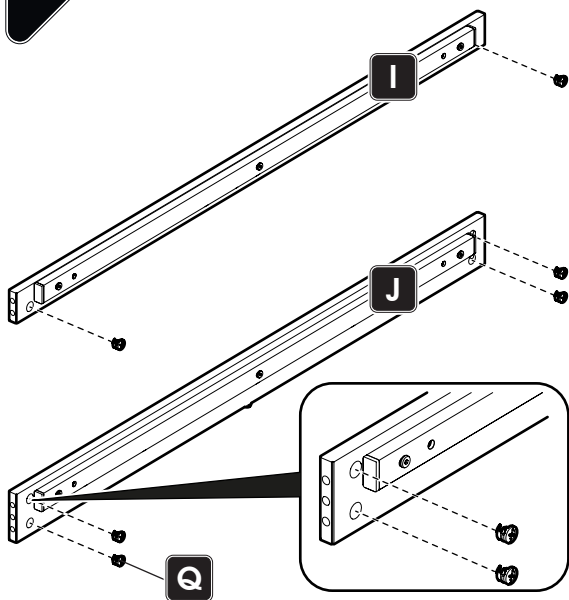
2

i

Arrow
Flèche
Flecha

Always ensure that the arrow on part **H** points towards the edge of the panel.
*Assurez-vous que la flèche sur la partie **H** soit dirigée vers le bord du panneau.*
Siempre asegúrese de que la flecha en la parte **H** apunta hacia el borde del panel.



Q
X6

3

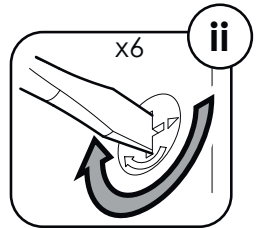
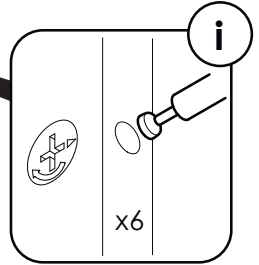
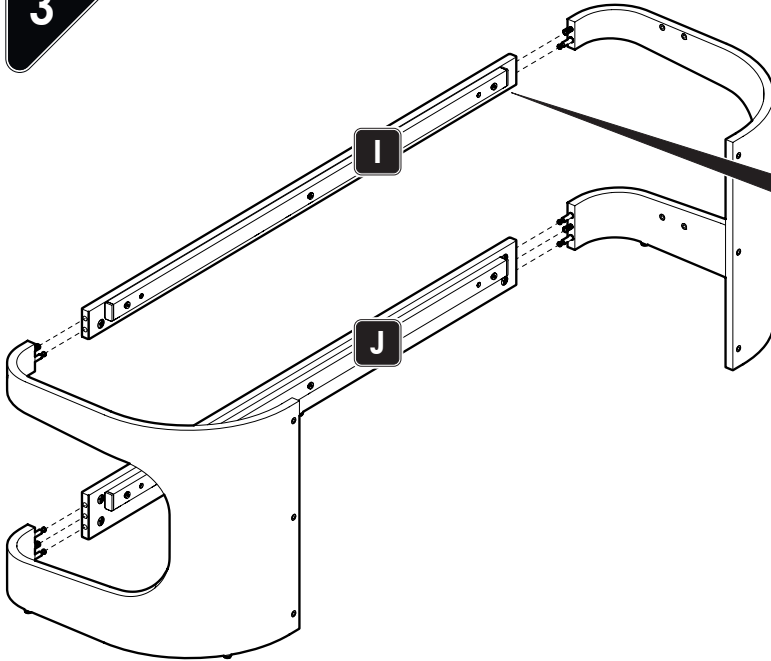

4

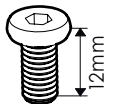
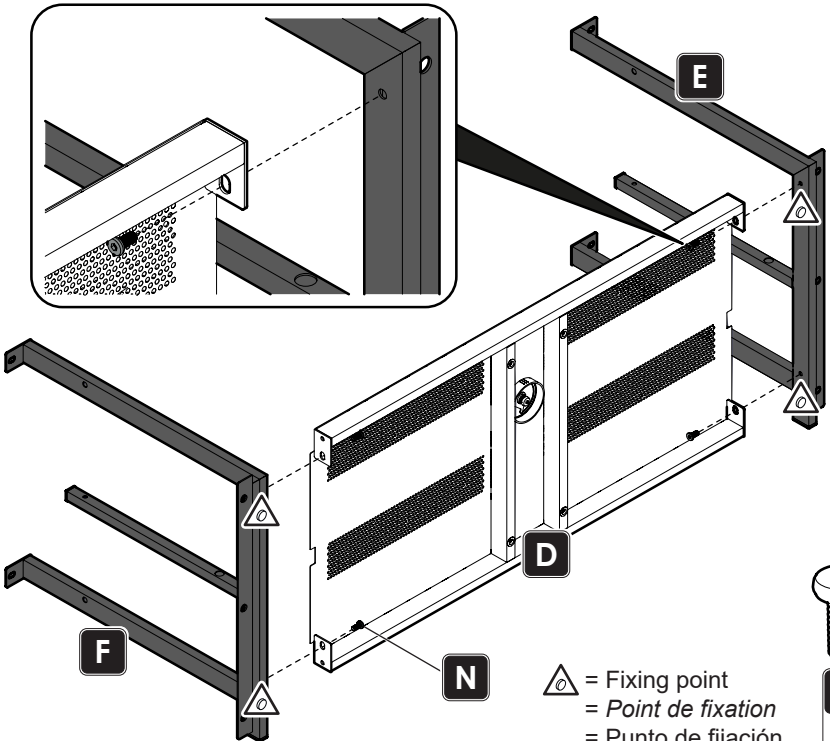

△ = Fixing point
 = Point de fixation
 = Punto de fijación

N
 X4

5

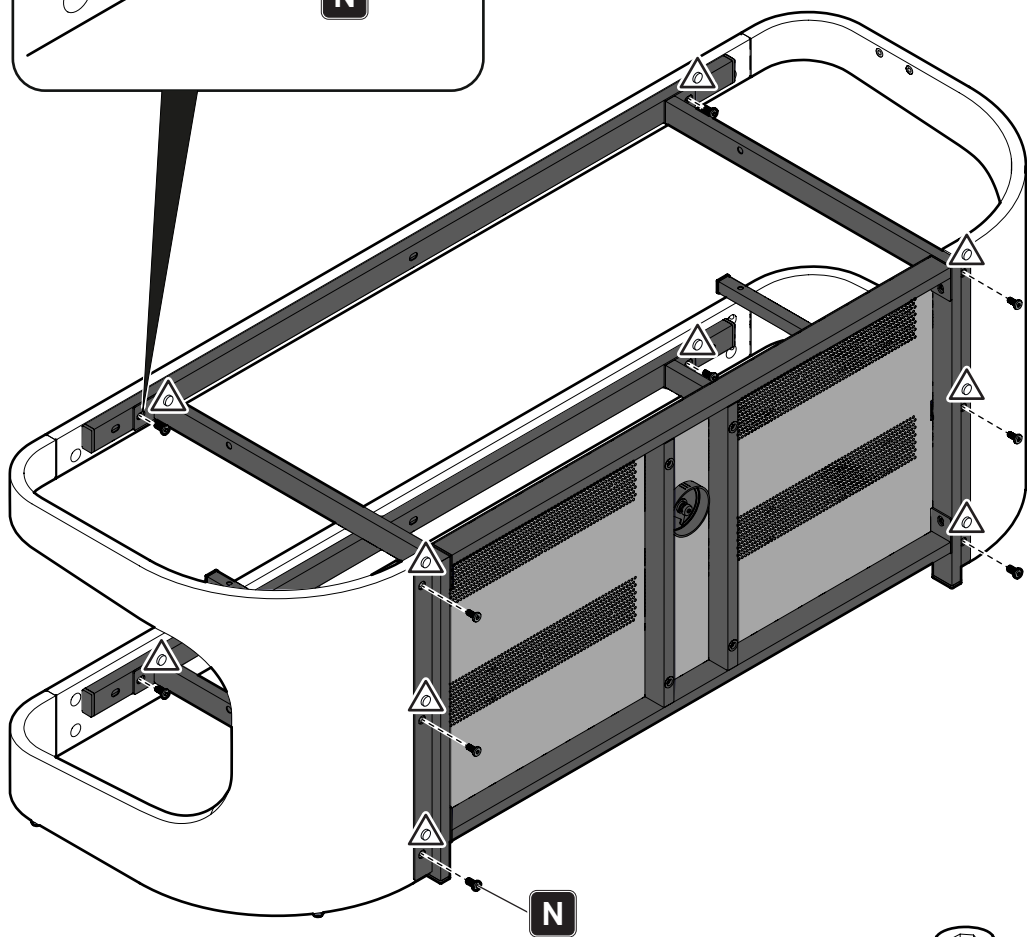
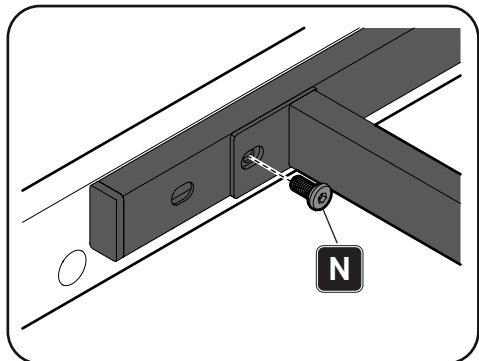

△ = Fixing point
= Point de fixation
= Punto de fijación

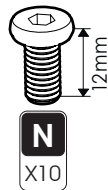

6

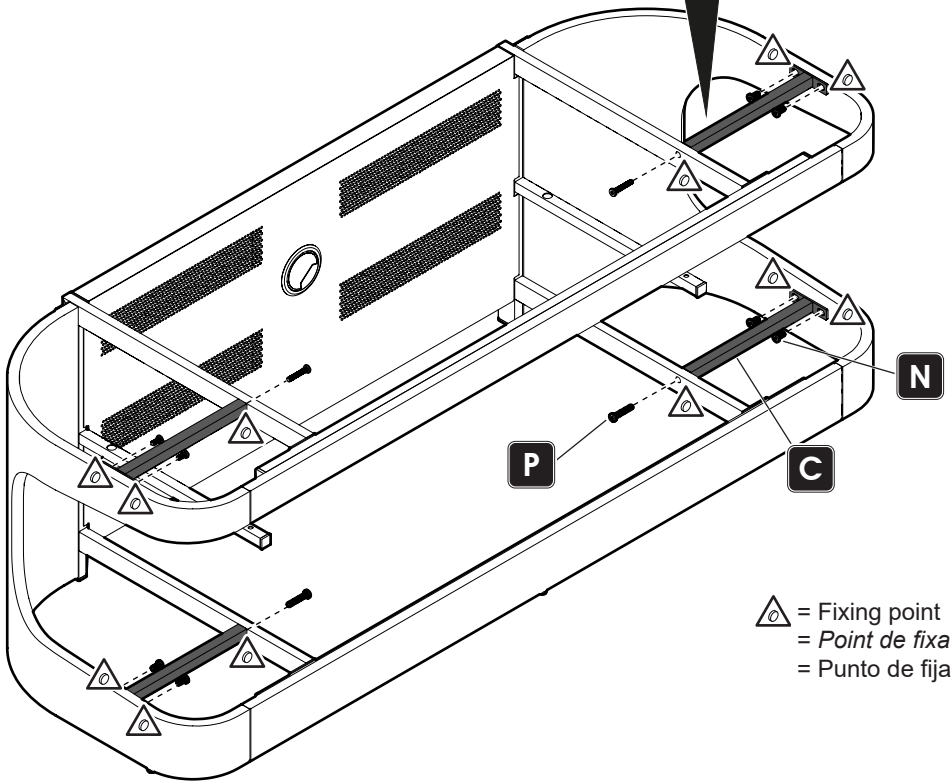
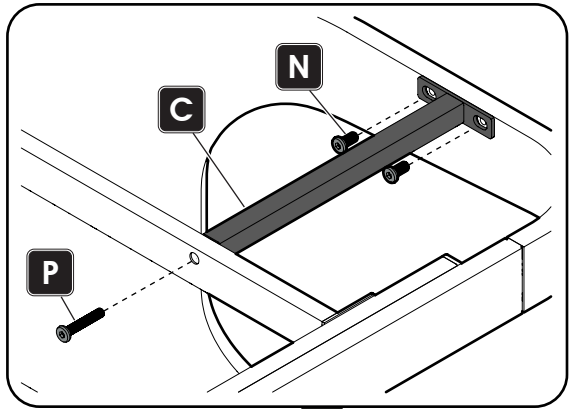

 = Fixing point
= Point de fixation
= Punto de fijación



Always use the correct screw. Failure to do so could result in damage to the unit.

Utilisez toujours la bonne vis. Sinon, ceci pourrait endommager l'unité.

Utilice siempre el tornillo correcto. No hacerlo así podría dar como resultado daños en la unidad.

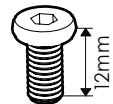

N
X8

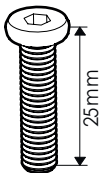

P
X4

7

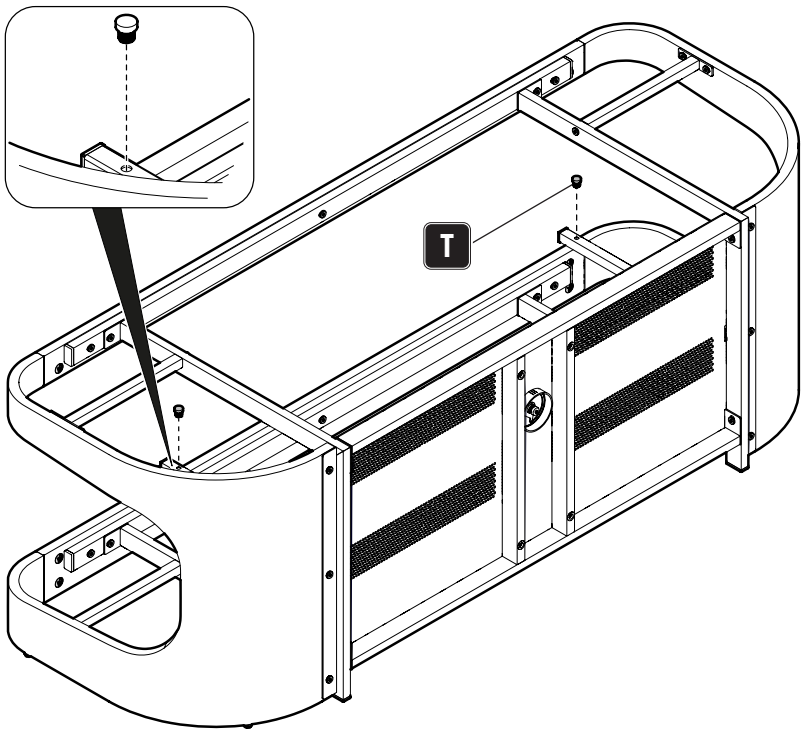

8

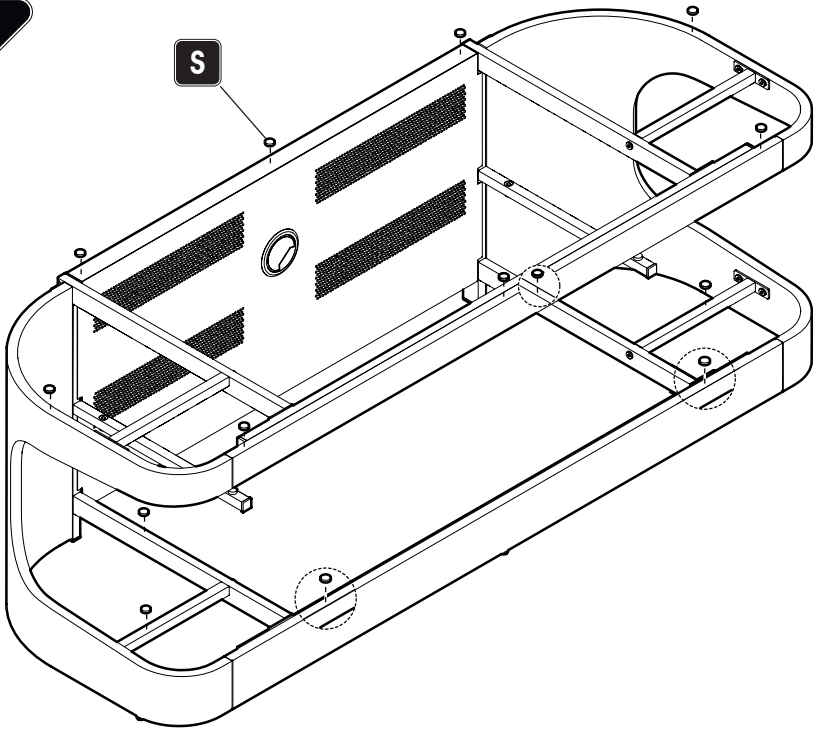

9

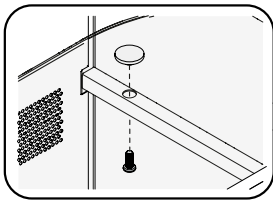

i
DO NOT overtighten
Ne serrez pas trop fort
No apriete demasiado

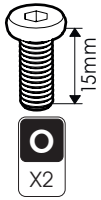
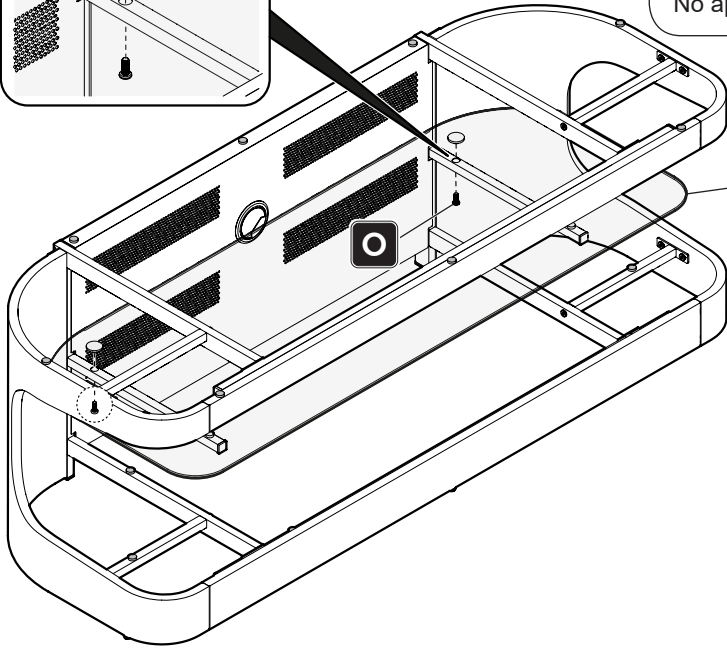

10

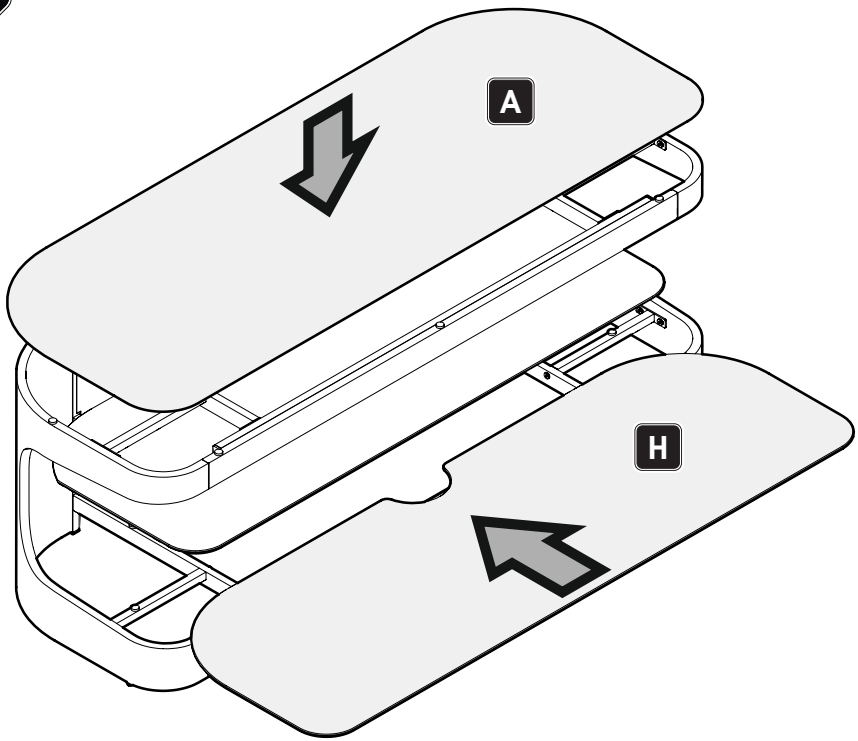

Levelling
Réglage du niveau
Nivelar

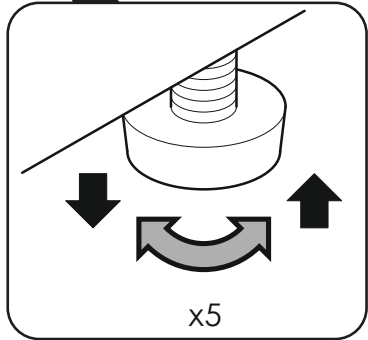
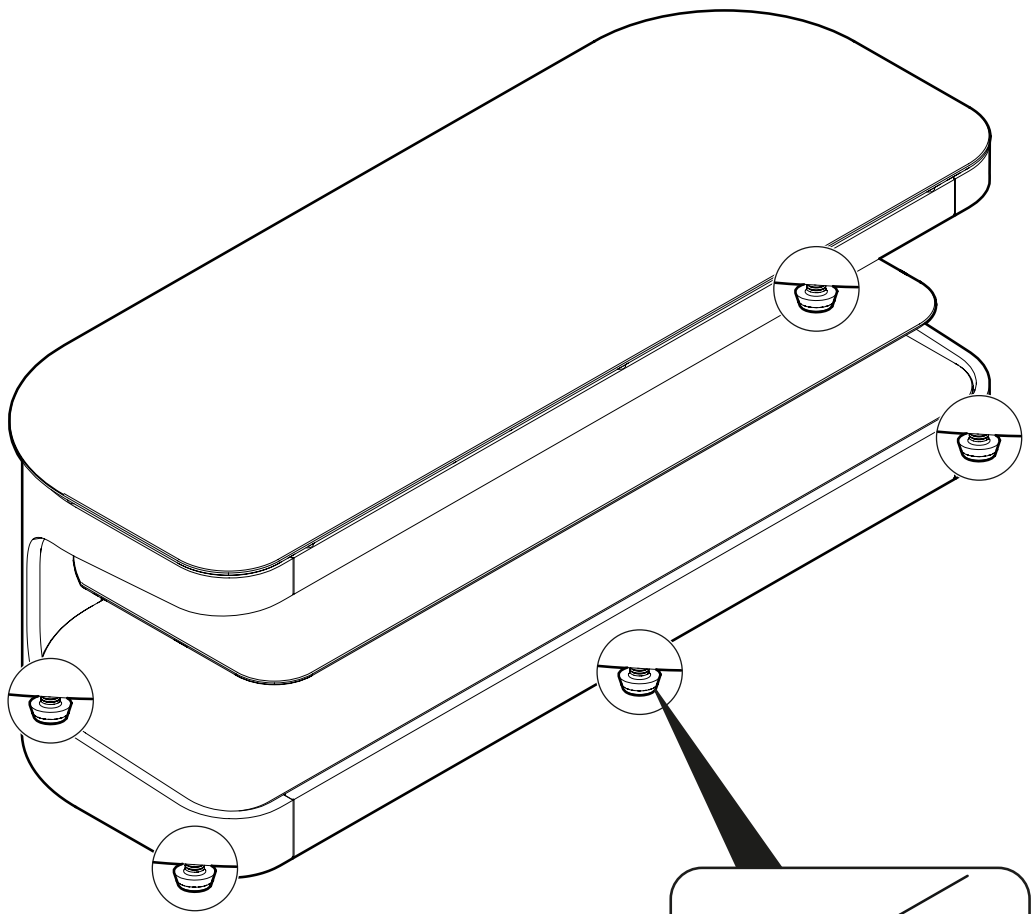

Cable management
Gestion des câblages
Manejo de Cable

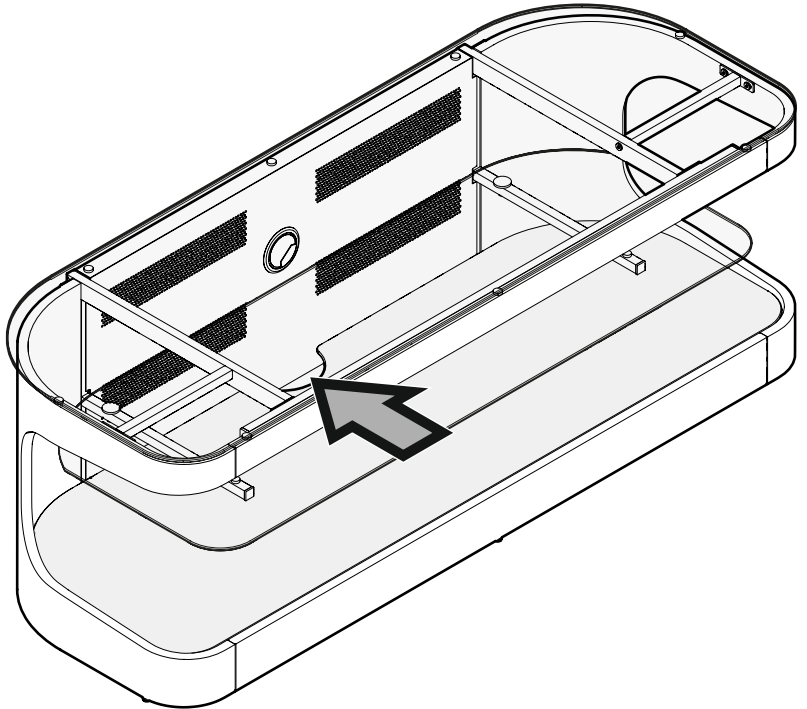
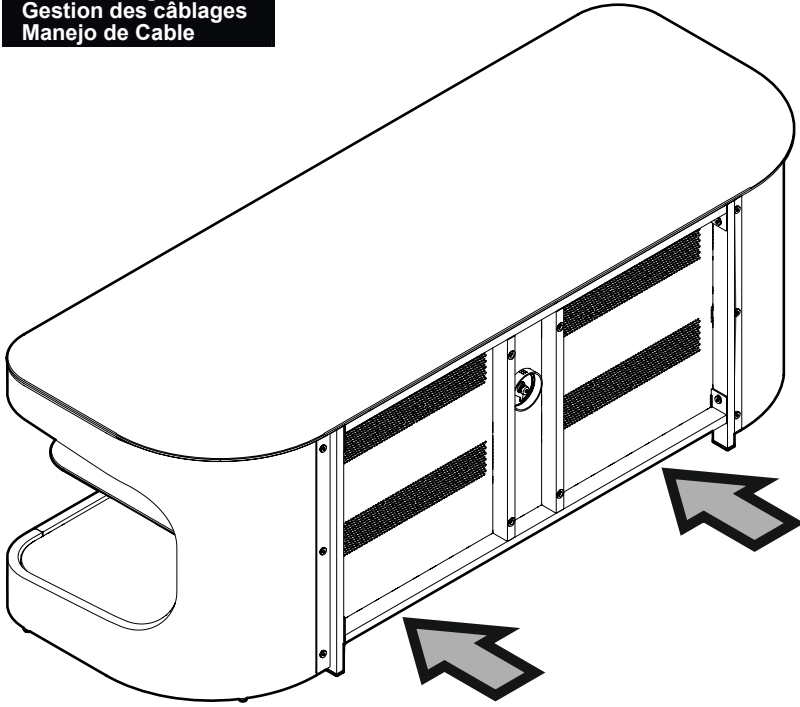

FL602KIT

If you are attaching column mount FL602KIT you will need to use the fixing types shown, for example **Type A** etc. Please see the FL602KIT instructions for more information.

*Si vous fixez le support colonne FL602KIT, vous devrez utiliser les types d'attache montrés, par exemple **Type A** etc. Veuillez lire les instructions de FL602KIT pour plus d'informations.*

Si va a colocar el soporte de columna FL602KIT, tendrá que utilizar los tipos de fijación que se muestran, por ejemplo **Tipo A** etc. Consulte las instrucciones de FL602KIT para obtener más información

