

STOP

**ARRETEZ
-VOUS**

ALTO

Read through ALL instructions before commencing assembly.

If you have any questions about this product or issues with assembly contact the customer services help line before returning this product to the store.

Lisez toutes les instructions avant de débiter l'installation.

Si vous avez des questions sur ce produit ou sur son installation, contactez le service d'assistance clientèle avant de renvoyer le produit au magasin.

Lea todas las instrucciones antes de empezar la instalación.

Si usted tiene alguna pregunta acerca de este producto o problemas con la instalación contacte los servicios de ayuda al cliente antes de devolver este producto a la tienda.

CUSTOMER SERVICES HELP LINE NUMBER:
NUMÉRO DE L'ASSISTANCE CLIENT:
NUMERO DE SERVICIO DE ATENCION AL CLIENTE:

+44 (0)333 320 0463 (UK)

CUSTOMER SERVICES HELP LINE NUMBER:
NUMÉRO DE L'ASSISTANCE CLIENT:
NUMERO DE SERVICIO DE ATENCION AL CLIENTE:

1-800 667 0808 (USA)

AVF Group Ltd.
Hortonwood 30, Telford,
Shropshire, TF1 7YE, England
www.avfgroup.com

AVF Group, Inc.
2775 Broadway, Cheektowaga,
Buffalo, New York, 14227, USA
www.avfgroup.com

IMPORTANT INFORMATION!

We advise that before starting the assembly of this product that you familiarise yourself with the instructions and the parts list in this leaflet.

INFORMATIONS IMPORTANTES!

Nous vous recommandons de vous familiariser avec ces instructions et la liste des pièces détachées contenues dans ce document avant de commencer l'assemblage de ce produit.

INFORMACIÓN IMPORTANTE!

Le recommandamos que antes de comenzar el ensamblaje de este producto se familiarize con las instrucciones y la lista de partes en esta hoja informativa.

Do not's

Do not over tighten any part of this assembly.

Do not place hot or cold objects on to or close next to any glass surface unless the object is sufficiently insulated to prevent contact.

Do not strike the glass with hard or pointed items.

Do not sit or stand upon horizontal glass surfaces.

Do not use washing powders or other substances containing abrasives when cleaning the glass.

À ne pas faire

Ne serrez pas trop fort aucun des éléments de cet assemblage.

Ne placez aucun objet froid ou chaud sur ou à proximité de toute surface en verre à moins que celui-ci ne présente une isolation suffisante pour empêcher tout contact.

Ne frappez pas les surfaces en verre avec des objets lourds ou pointus.

Ne vous asseyez ni ne montez pas sur les surfaces horizontales en verre.

N'utilisez pas de poudre à récurer ou toute autre substance abrasive lorsque vous nettoierez les surfaces en verre car cela risquerait de provoquer des rayures.

No haga

No apriete demasiado ninguna de las piezas de este soporte.

No coloque objetos calientes o fríos en o cerca de cualquier superficie de vidrio, a menos que el objeto esté aislado para prevenir contacto directo.

No golpee el vidrio con artículos fuertes o punzantes.

No se siente o se pare en superficies de vidrio.

No use detergentes para lavar u otras sustancias que contengan abrasivos cuando esté limpiando el vidrio ya que estas pueden rayarlo.

Do's

Do use a damp cloth with diluted washing up liquid for cleaning the glass surfaces.

Do use a soft cloth with a suitable furniture polish when cleaning wooden panels.

À faire

Utilisez un chiffon humide imprégné de liquide vaisselle dilué pour le nettoyage des surfaces en verre.

Utilisez un chiffon doux avec un produit adapté pour le nettoyage des meubles afin de nettoyer les panneaux en bois.

Si haga

Use un trapo suave con líquido diluido en agua para limpiar las superficies de vidrio.

Use un trapo suave con limpiador o embellecedor de muebles cuando limpie paneles de madera.

Maximum TV weight and shelf capacities

Poids maximal du téléviseur et capacité de charge de l'étagère

Máximo peso y capacidad del estante de TV



2 Person Assembly
Assemblée de 2 personnes
Reunión de 2 personas

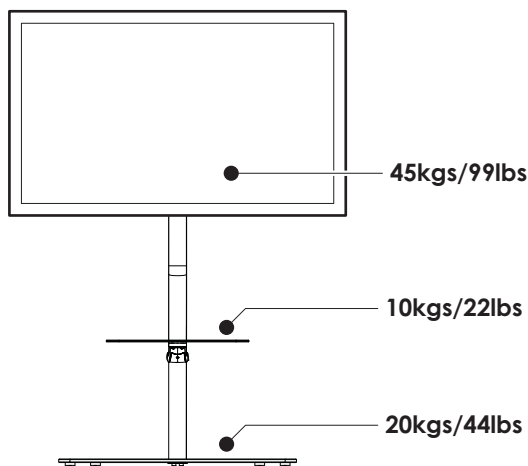

WARNING: Wherever possible distribute weight evenly.

AVERTISSEMENT: Répartissez le poids de manière uniforme lorsque cela est possible.

ADVERTENCIA: En la medida de lo posible distribuya el peso uniformemente.

IMPORTANT: Check all nuts and bolts from time to time.

IMPORTANTES: Vérifiez tous les écrous et les boulons de temps à autre.

IMPORTANTE: Compruebe todos los tornillos y tuercas de vez en cuando.

Boxed Parts
Pièces empaquetées
Piezas en la Caja

Tools Recommended
Outils recommandés
Herramientas recomendadas

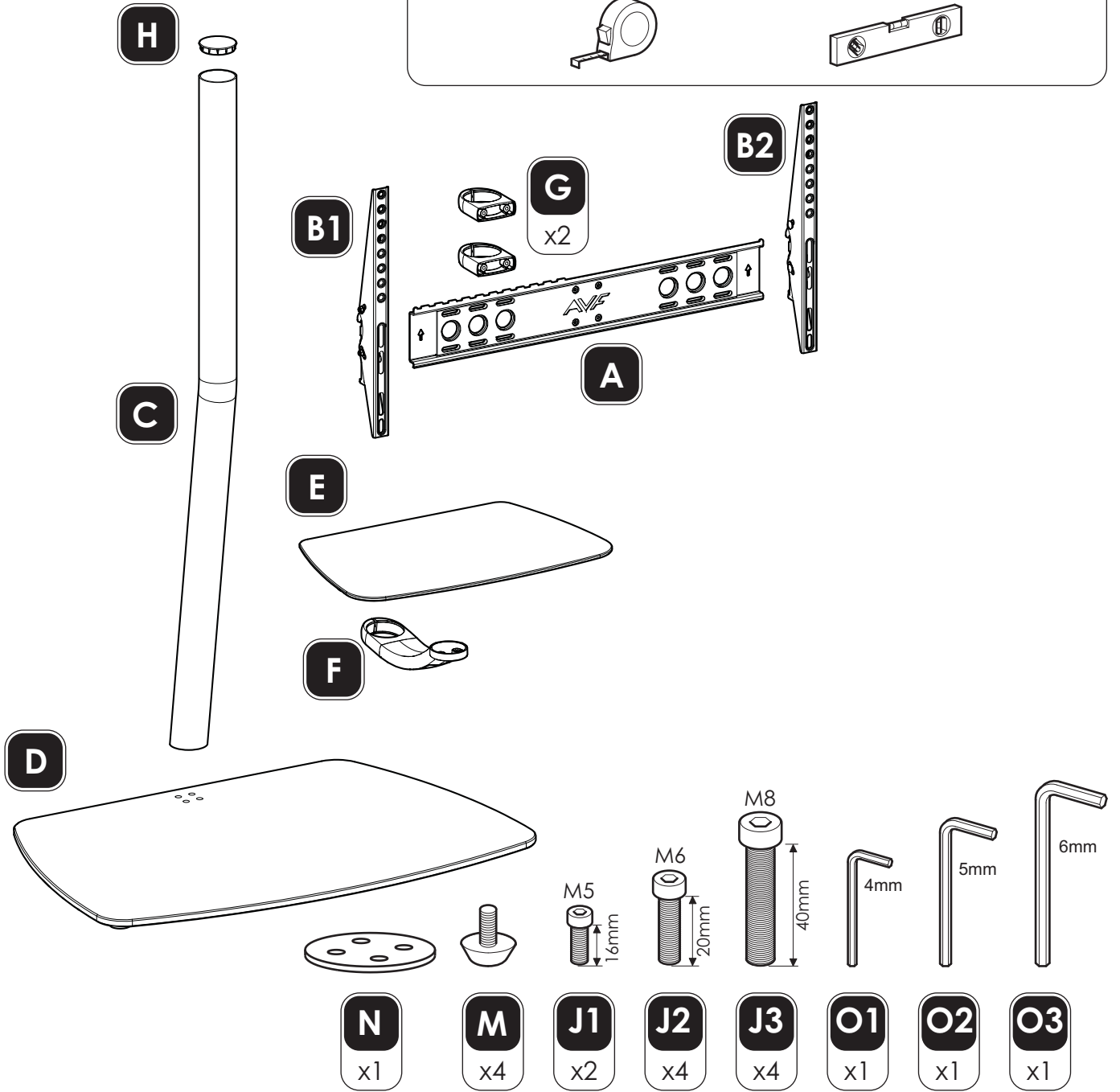
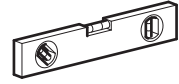
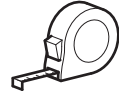

TV Screws, Reducers and Spacers
Vis TV, réducteurs et séparateurs
Tornillos, Reductores y Espaciadores para TV

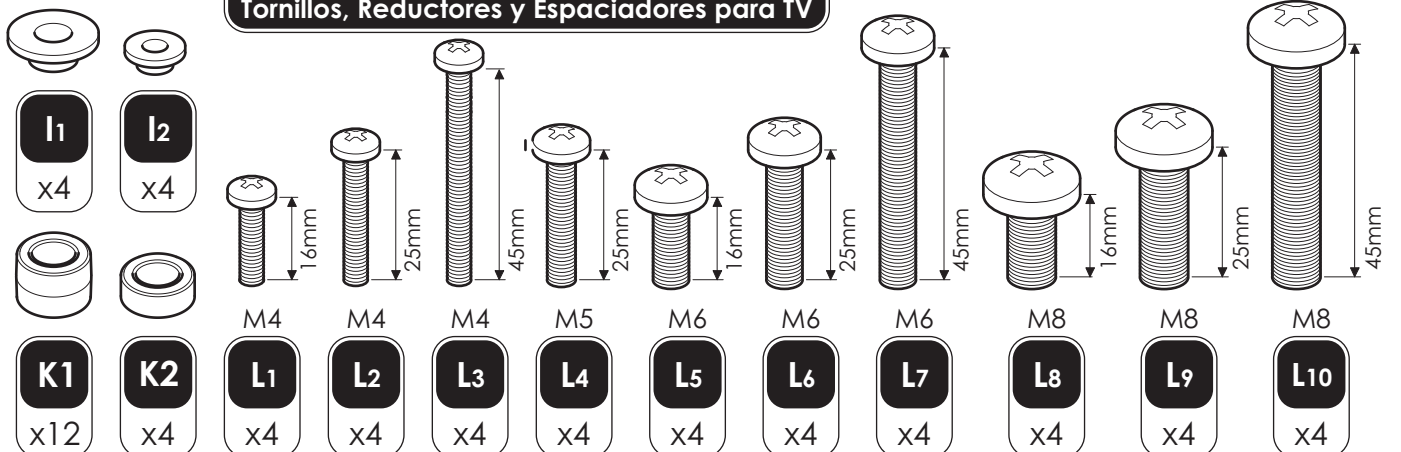

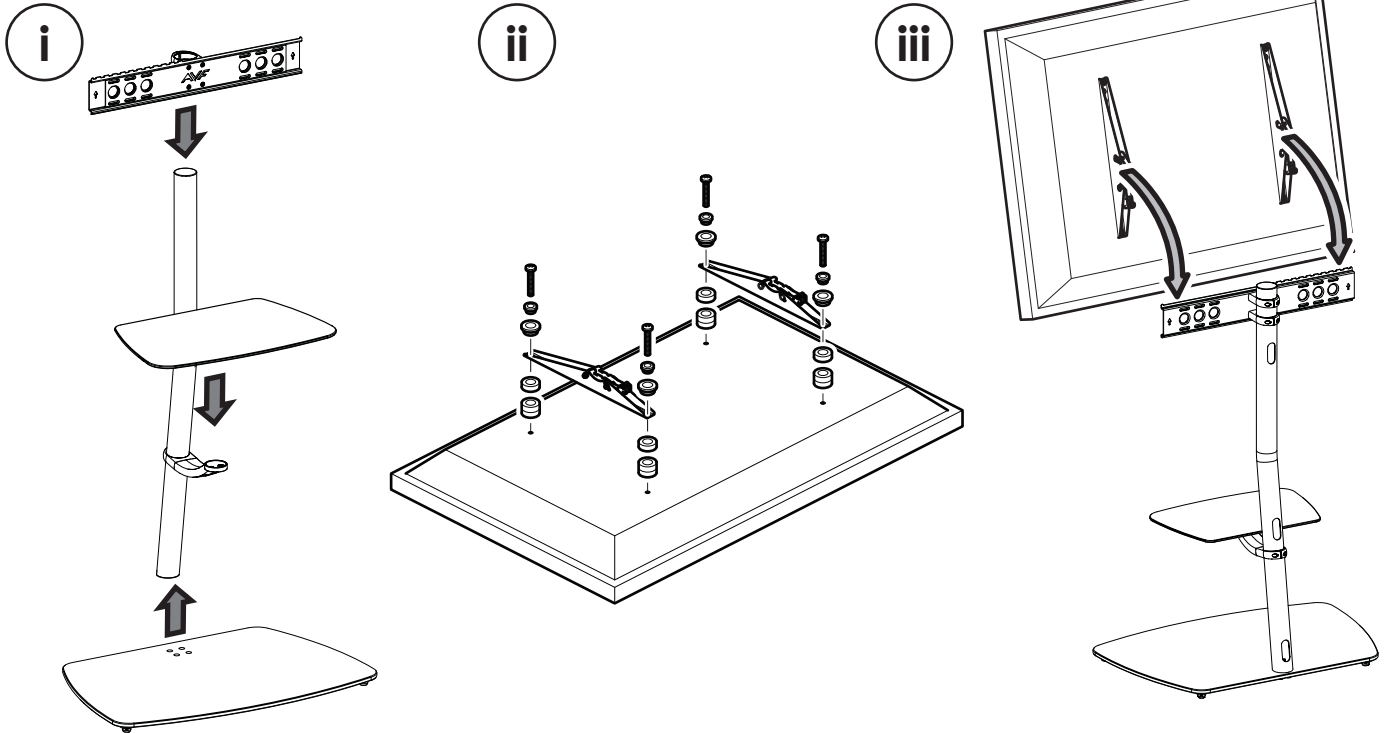

1

Measure the TV fixing holes Width and Height
 Mesurer la profondeur et la taille des trous de fixation
 Mida los orificios de su TV, lo ancho y lo alto

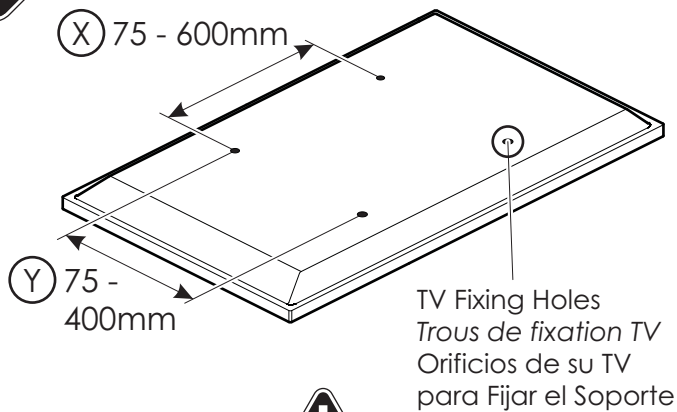

- M4** = L1/L2/L3
- M5** = L4
- M6** = L5/L6/L7
- M8** = L8/L9/L10

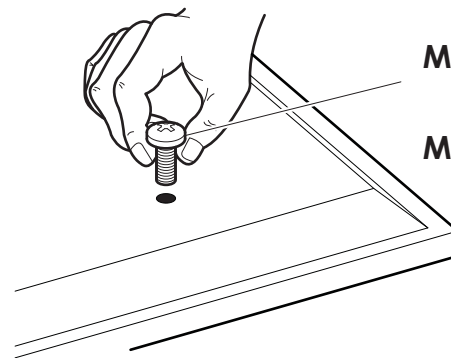

If width **X** is greater than 600mm or height **Y** greater than 400mm STOP installation now and contact the customer help line
 Si la largeur **X** est plus large que 600mm et la hauteur **Y** plus grande que 400mm, ARRÊTEZ l'installation immédiatement et contactez l'assistance client
 Si la anchura **X** es mayor que 600mm o la altura de **Y** es mayor que 400mm DETENGA la instalación inmediatamente y póngase en contacto con la línea de ayuda al cliente

You are provided with 4 diameters of TV fixing screws, **M4**, **M5**, **M6** and **M8**. Determine the screw diameter that fits and remember for step 11.
 4 diamètres de vis TV vous sont fournis, **M4**, **M5**, **M6** et **M8**. Déterminez le diamètre de la vis qui convient et mémorisez-le pour l'étape 11.
 Se le proporciona con 4 diámetros de tornillos de fijación para su TV: **M4**, **M5**, **M6** y **M8**. Determine el diámetro del tornillo que le quede a su TV y recuérdelo para el paso 11.

2

C



4mm

O1
x1

Set shelf at approximate height
and fully tighten
*Fixer l'étagère à la hauteur approximative
et serrer complètement*
Colocar el estante a una altura
aproximada y ajustar completamente



F

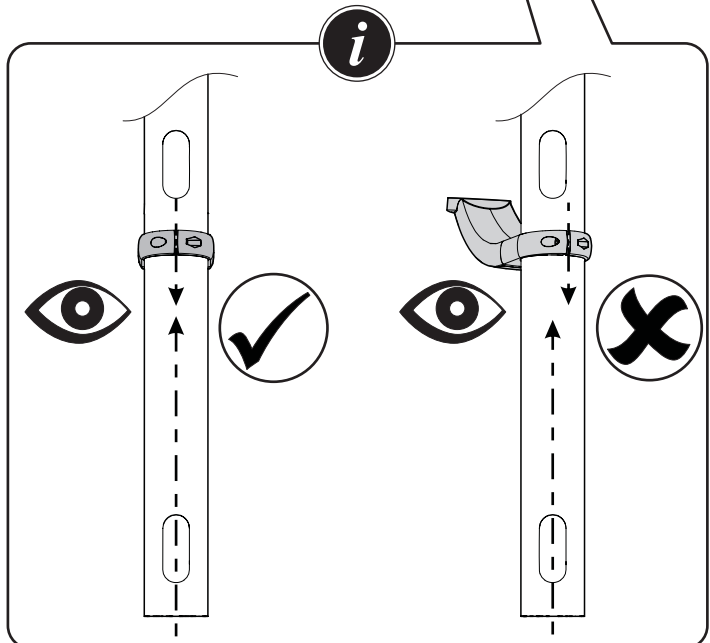
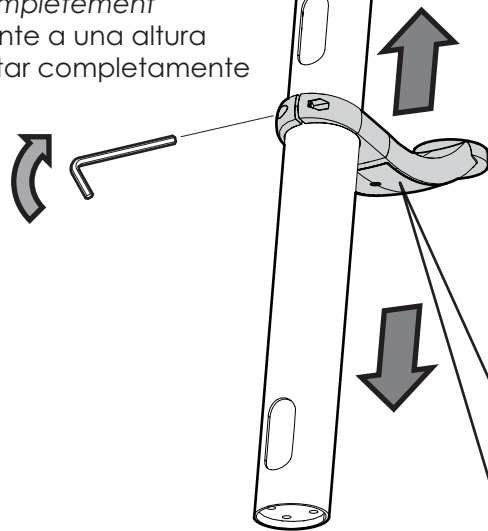
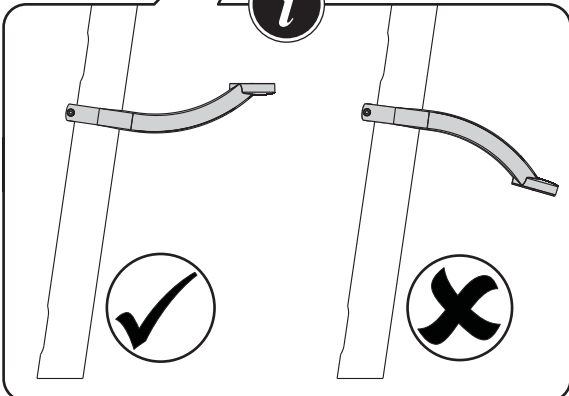
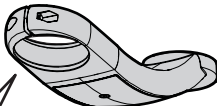

3

Evenly Screw the feet in place
Visser uniformément les pieds en place
Atornillar uniformemente las bases en su lugar

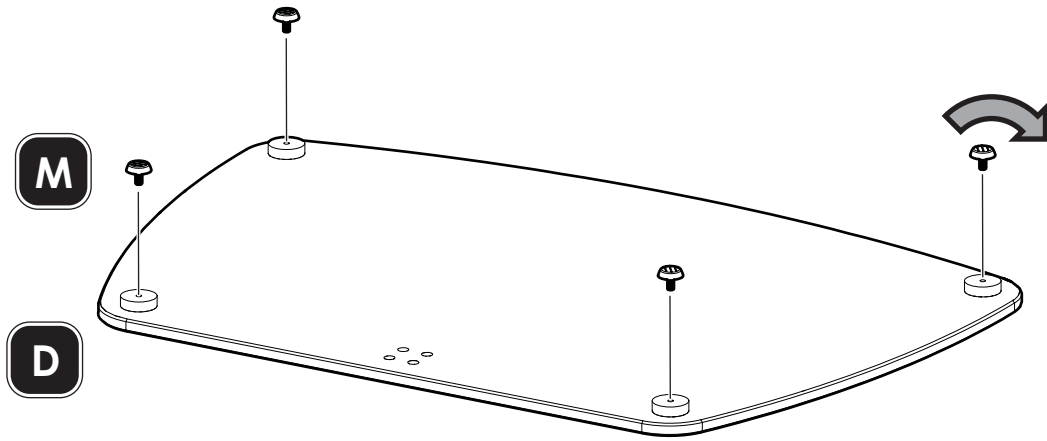

M
x4

4

Support the glass base
Soutenir le socle en verre
Apoyar la base de vidrio

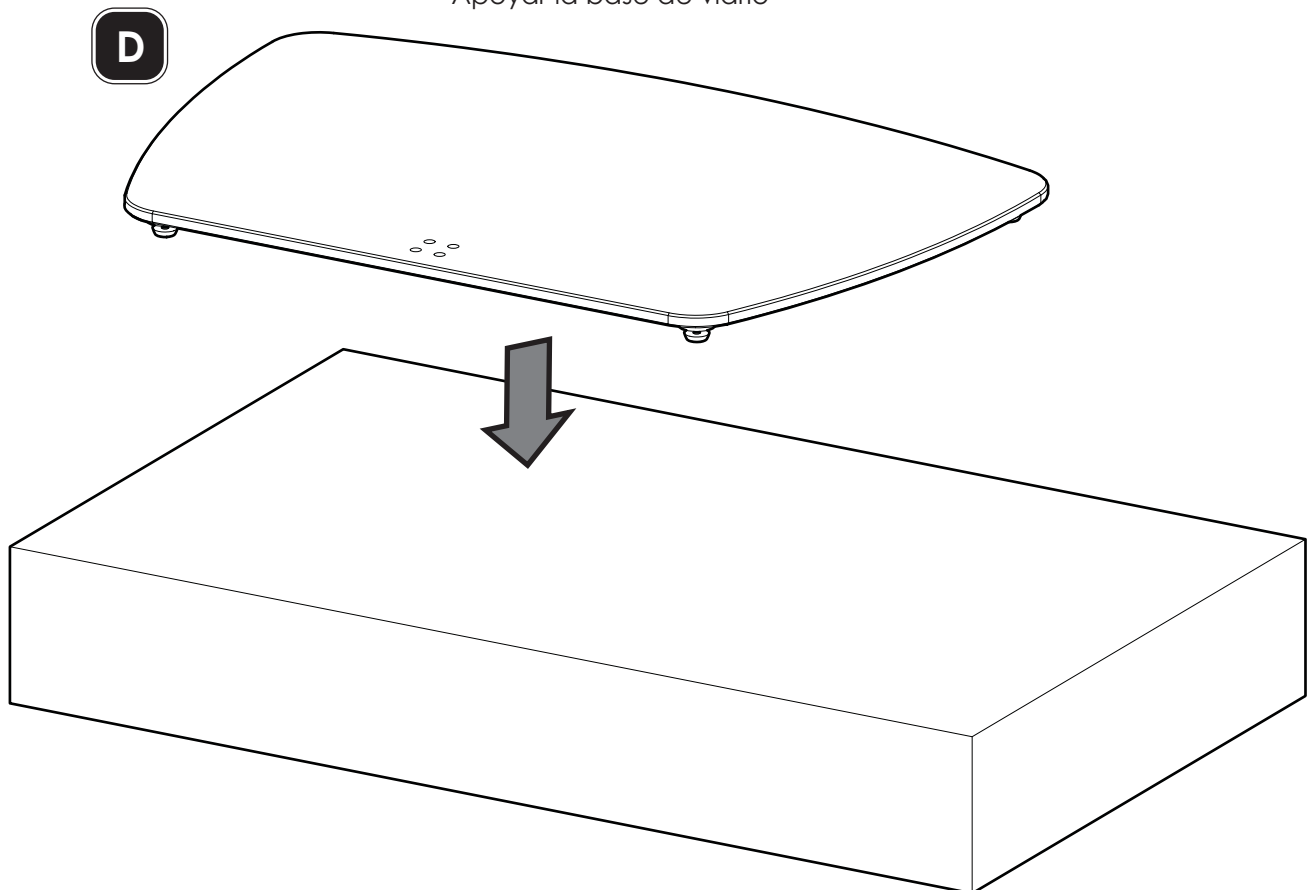

5

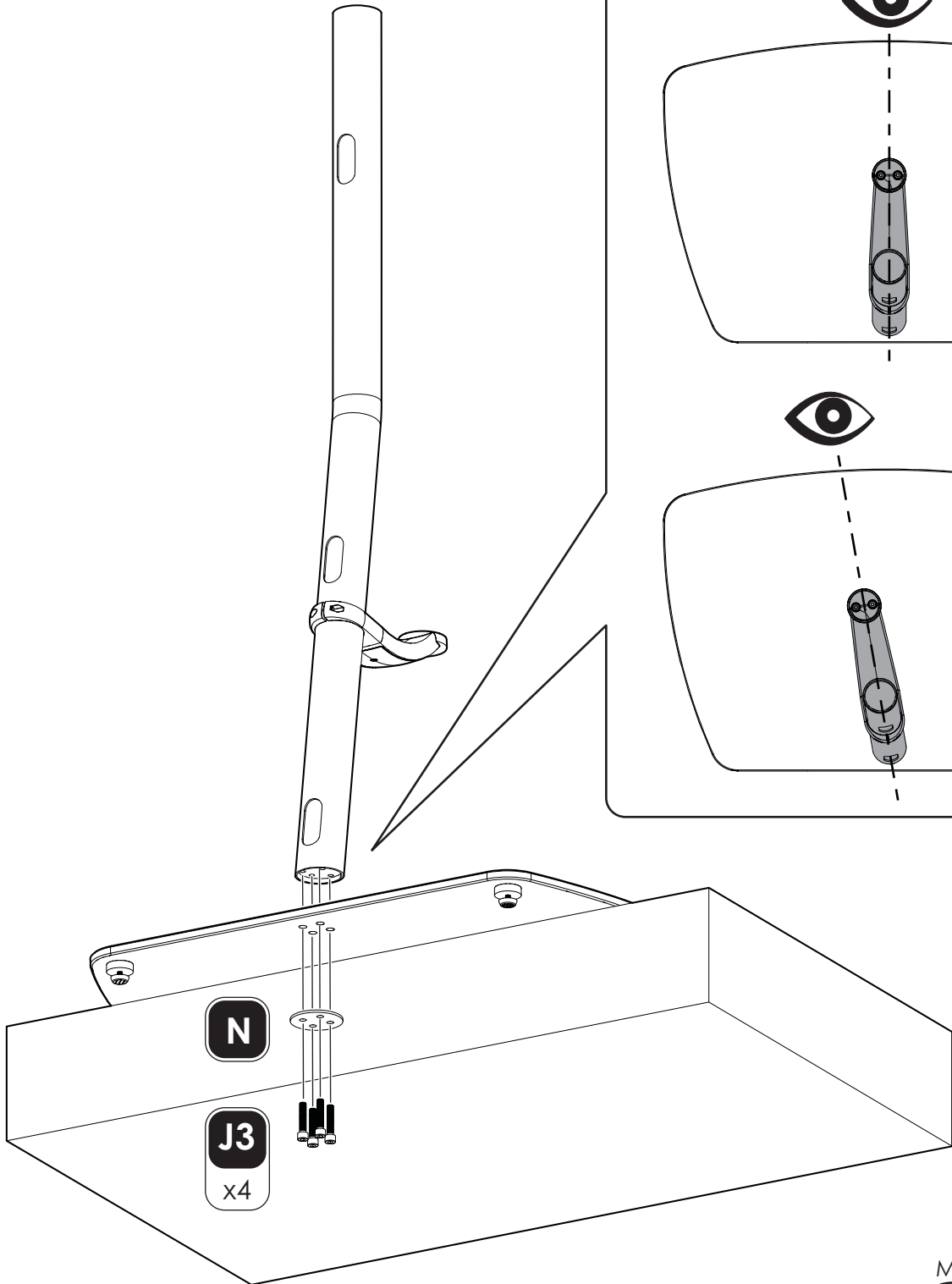
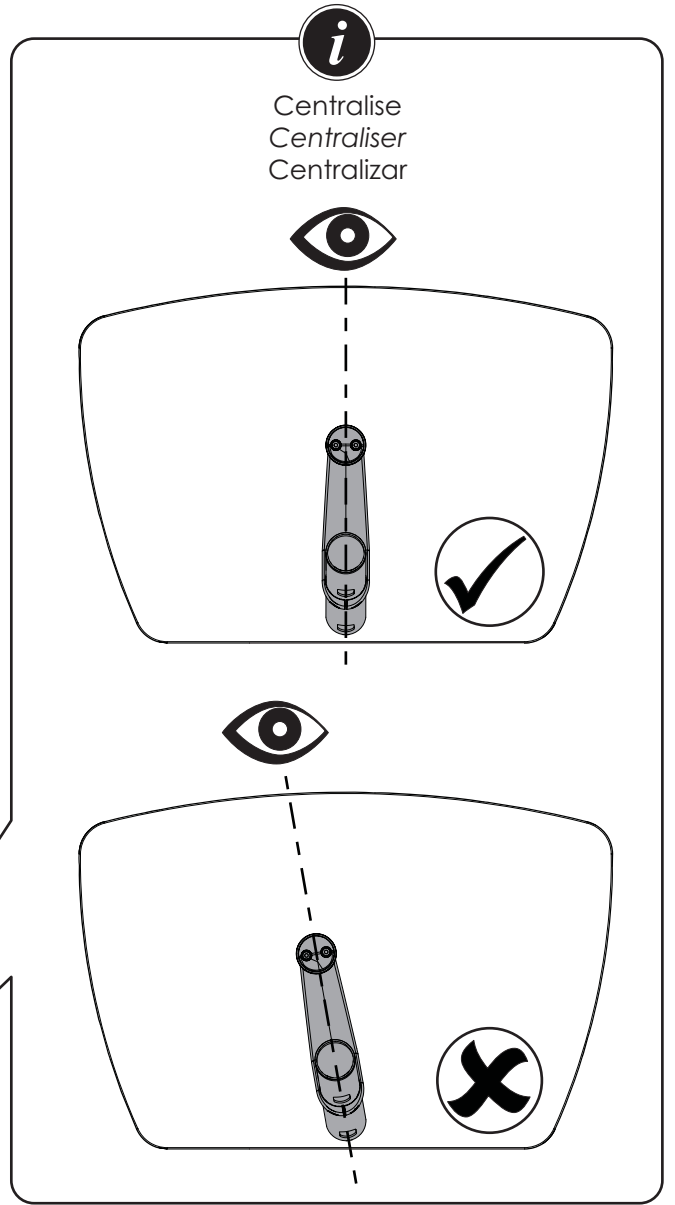

IMPORTANT / IMPORTANTES / IMPORTANTE

Once Centralised fully tighten the bolts
Lorsque l'étagère est bien au centre, serrer entièrement les boulons
Una vez Centralizada, ajustar totalmente los tornillos

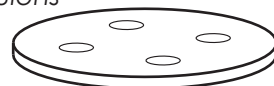

N
x1

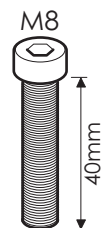

J3
x4



O3
x1

6

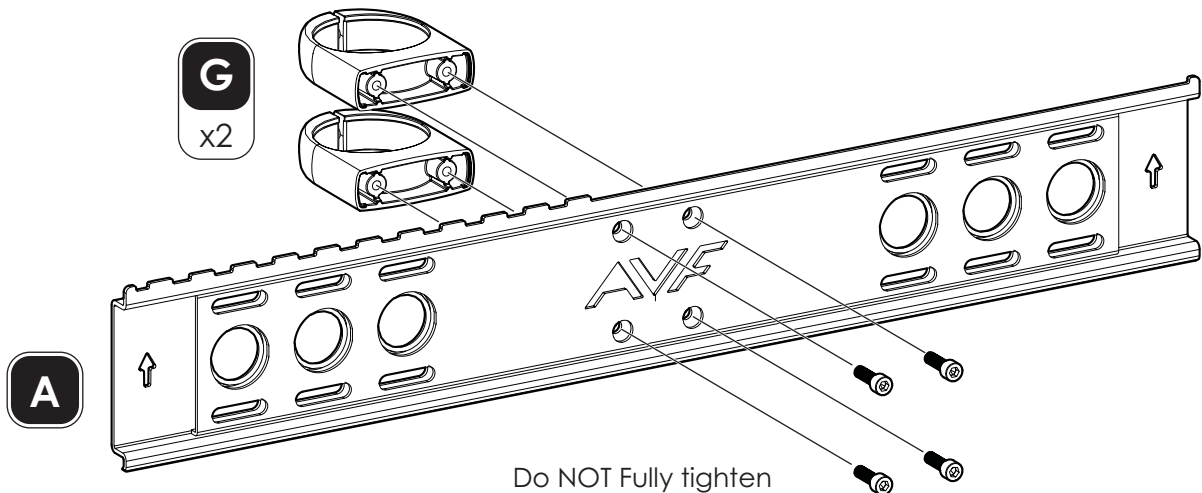

Do NOT Fully tighten
Ne PAS serrer complètement
NO ajustar Totalmente

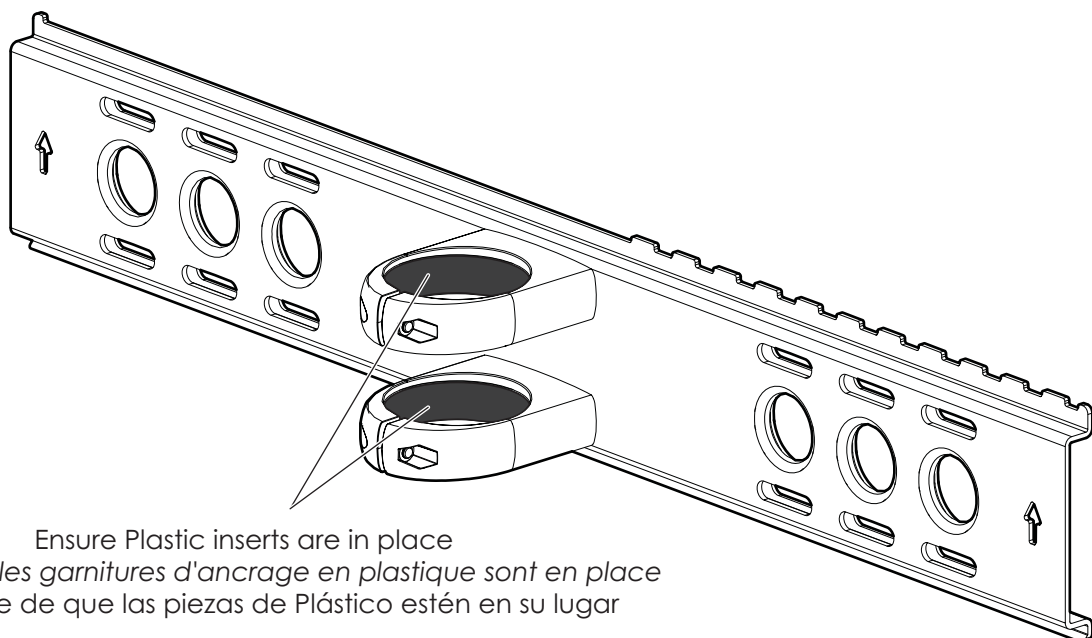
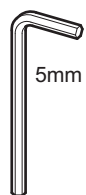
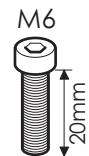

Ensure Plastic inserts are in place
S'assurer que les garnitures d'ancrage en plastique sont en place
Asegurarse de que las piezas de Plástico estén en su lugar

7

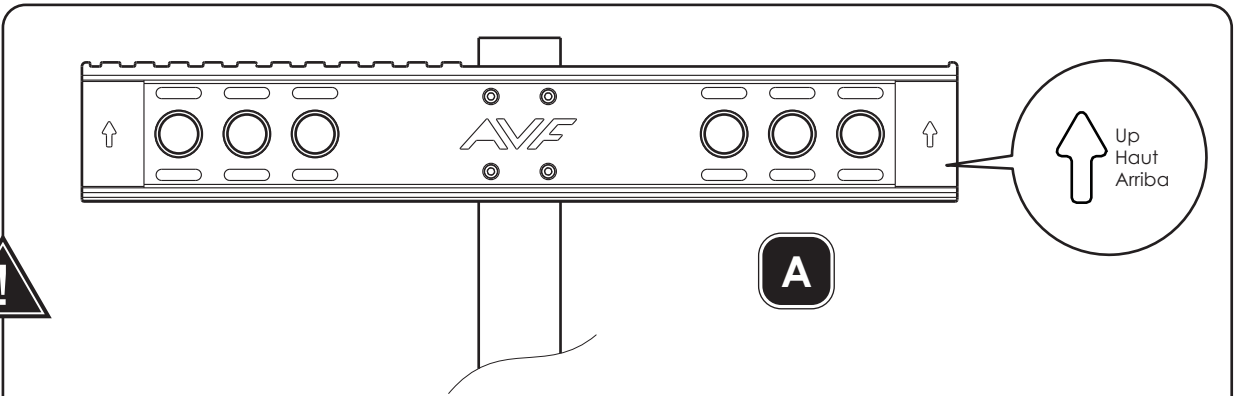

IMPORTANT! It is essential you fit fixing plate **A** the correct way up
IMPORTANT! Il est essentiel que vous orientiez le haut de la pièce de fixation **A** dans le bon sens
IMPORTANTE! Es imprescindible instalar la placa de fijación **A** orientada correctamente hacia arriba

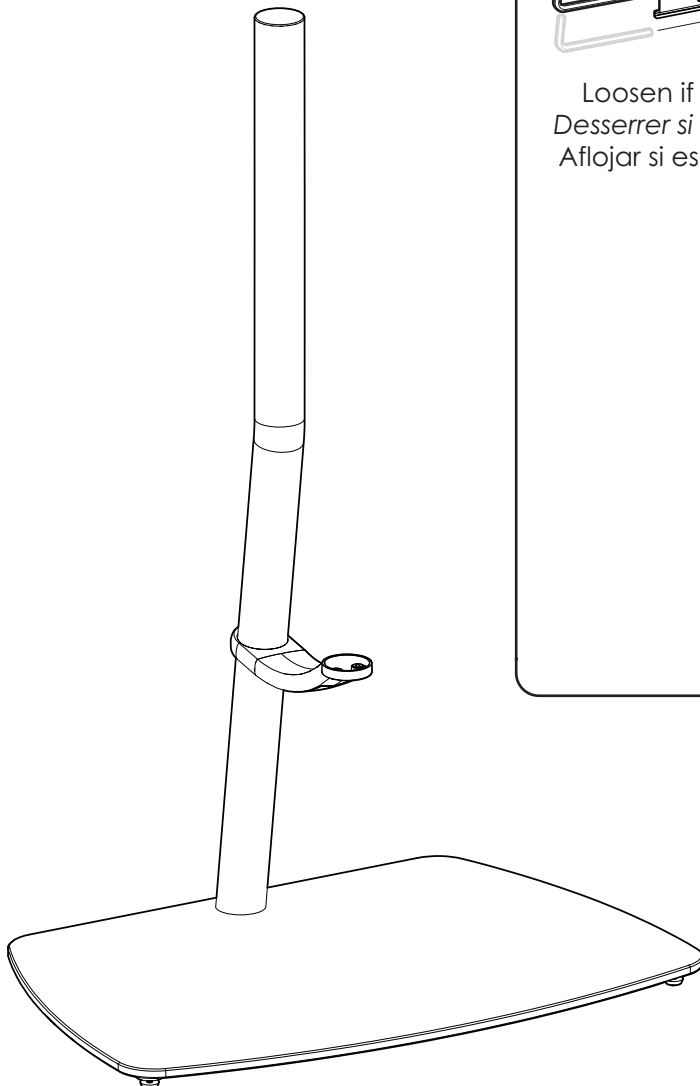
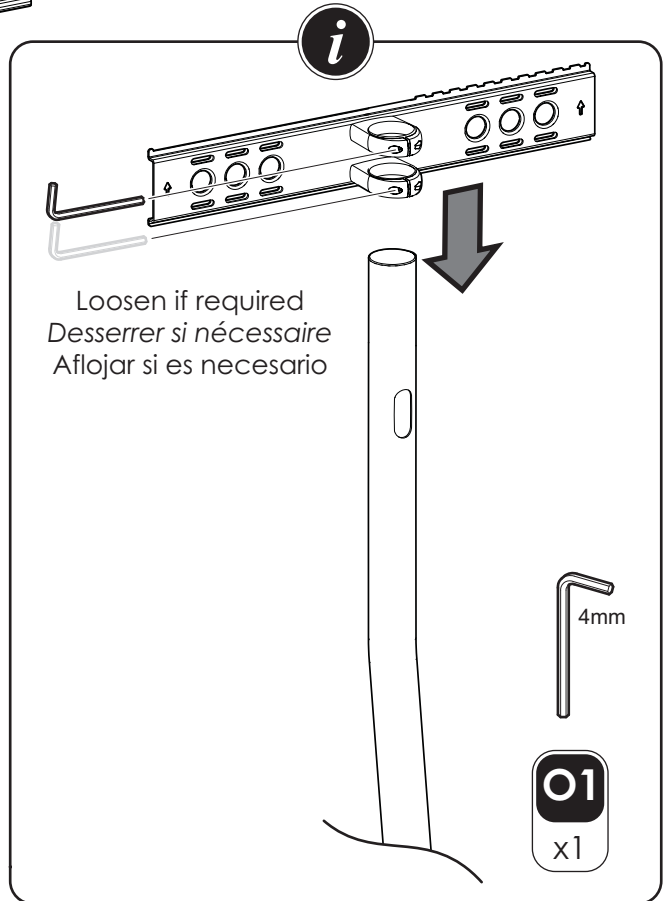
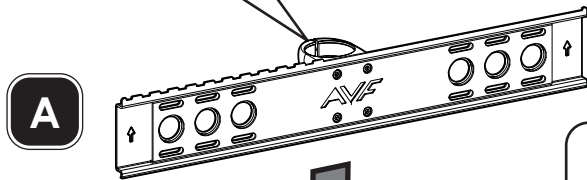

8

i Please consider the size of your TV before fixing **A**.
Veuillez prendre en compte la taille de votre TV avant de fixer **A**.
Considere por favor el tamaño de su TV antes de fijar **A**.

A

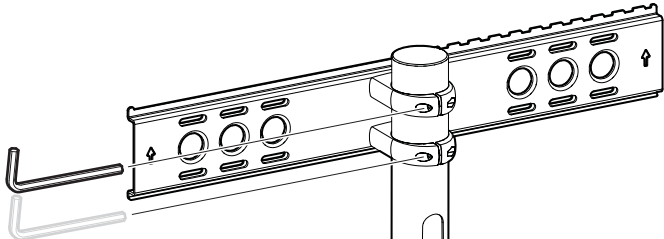
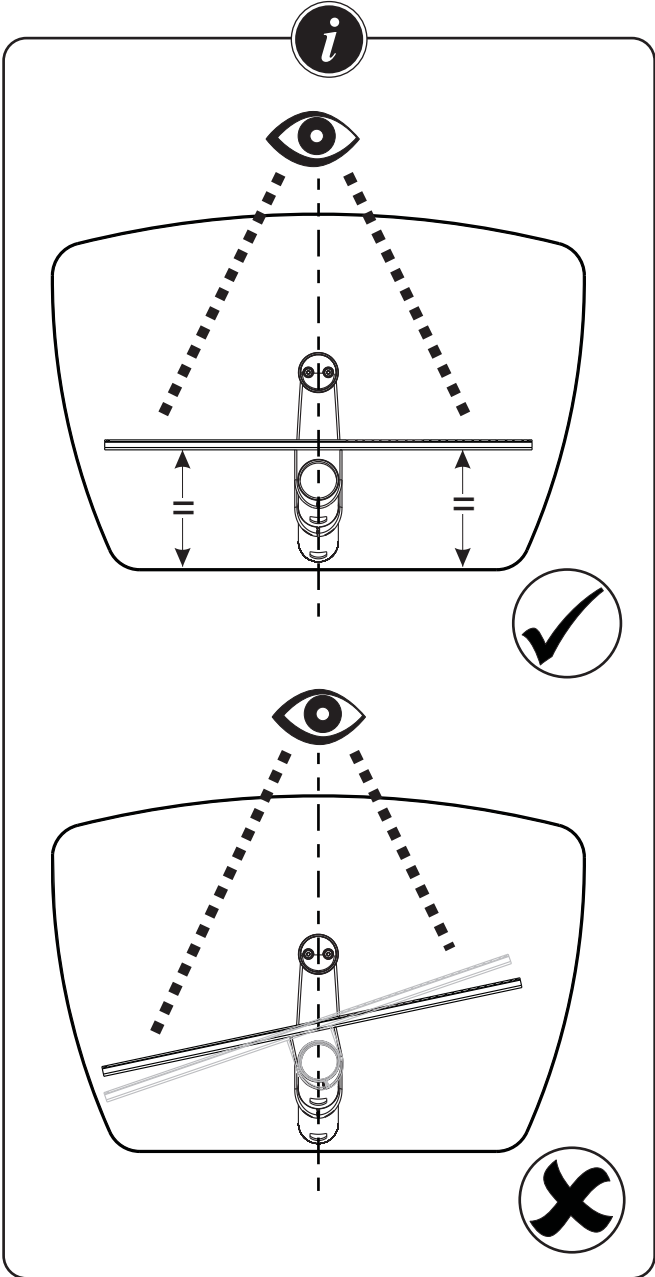
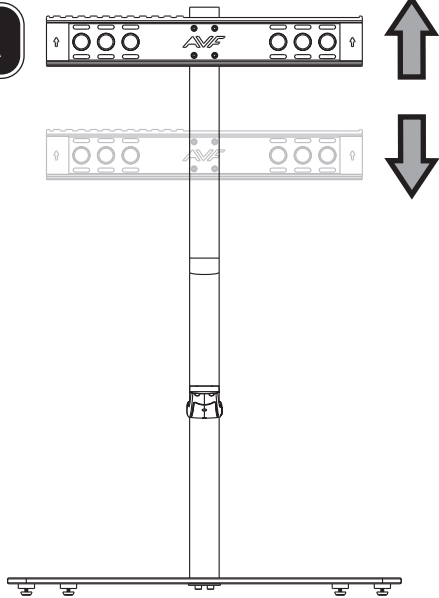

Fully tighten
Serrez complètement
Ajustar completamente

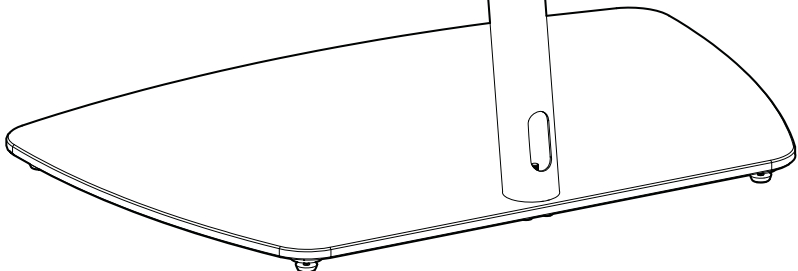

O1
x1

9

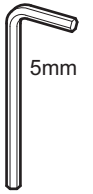
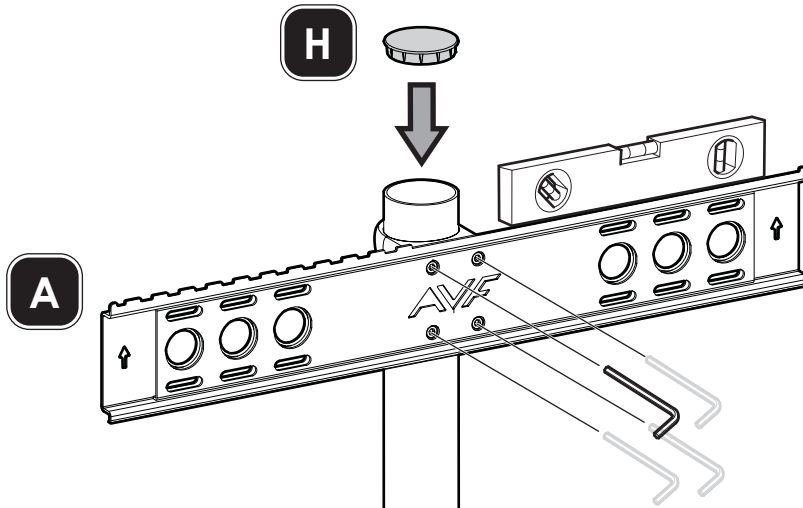

O2
x1

Check bracket **A** is level before fully tightening.
*Vérifiez si le support **A** est au niveau, avant de serrer complètement.*
 Revise si el soporte **A** está nivelado antes de ajustar completamente.

E

Adjust the feet if required
Régler les pieds si nécessaire
 Ajustar las bases si es necesario

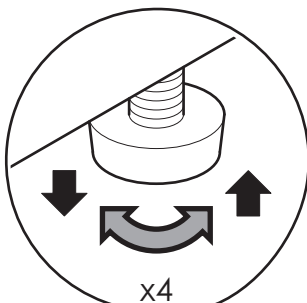

x4

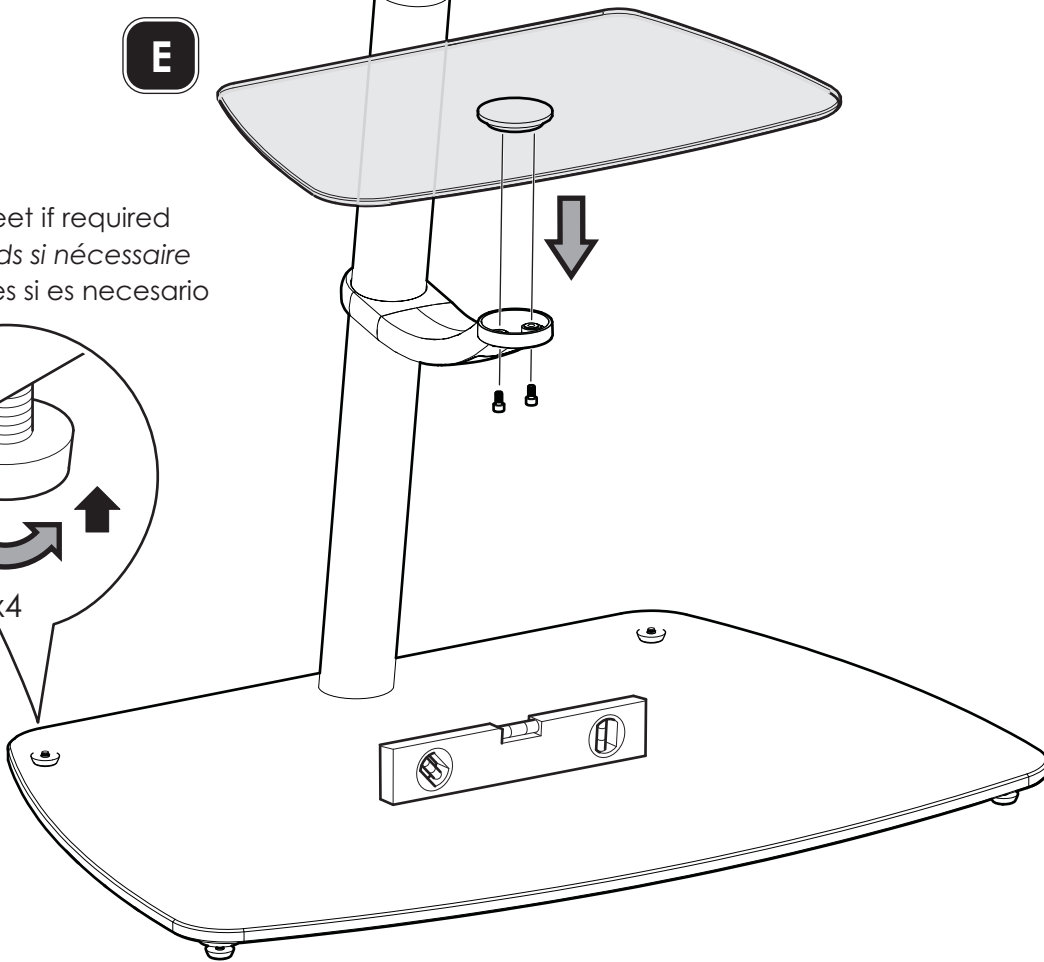

H
x1

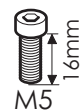

J1
x2

O1
x1

IMPORTANT / IMPORTANTES / IMPORTANTE

Before attaching your TV ensure you have tightened all nuts and bolts
Avant de fixer votre télé assurez-vous d'avoir serré tous les boulons et les écrous
 Antes de colocar su televisor asegúrese de haber apretado las tuercas y los pernos

10**No Spacers
Pas de Séparateur
Sin espaciadores**

For TVs with flat/unobstructed back
 Pour des téléviseurs aux dos plats et non obstrués
 Para TVs con la parte posterior plana/sin obstáculos

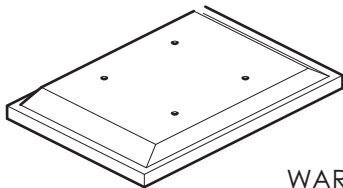
**Spacers
Séparateur
Espaciadores****R/B**

For TVs with irregular/obstructed back
 Pour des téléviseurs aux dos irréguliers et non obstrués
 Para TVs con la parte posterior irregular/con obstáculos

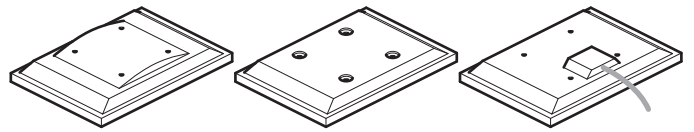
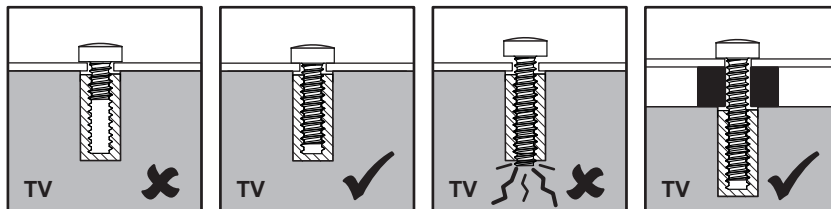
**WARNING / AVERTISSEMENT / ADVERTENCIA**

After completing step 11 you will have fittings left over, please keep for future reference.
 Après avoir complété l'étape 11 il vous restera des pièces d'assemblage, conservez-les.
 Después de completar el paso 11 usted tendrá conexiones sobrantes, por favor guarde para futura referencia.

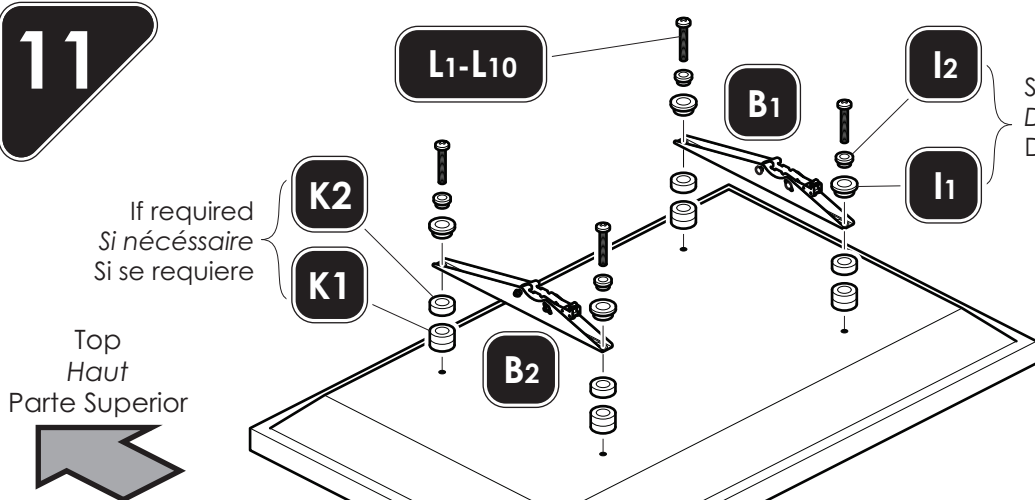
11

Screw diameter dependant
 Dépendant du diamètre de la vis
 Depend del diámetro de tornillo

Attach the bracket to the back of your TV using suitable screw, reducer and spacer combinations. If you have any issues fitting to the back of your TV with the supplied screws, please call the customer services helpline.

Attachez l'applique au dos de votre téléviseur en utilisant une combinaison de vis, de séparateurs et de joints adaptés. Si vous rencontrez un quelconque problème lors de l'installation, au moyen des vis fournies, avec la partie arrière de votre TV, veuillez appeler le numéro d'assistance du service clientèle.

Coloque los soportes a la parte posterior de su TV usando la combinación adecuada de tornillo, reductor y espaciador. Si tiene usted algún problema armando la parte posterior de su televisor con los tornillos provistos, llame por favor a la línea de asistencia de nuestro servicio de atención al cliente.

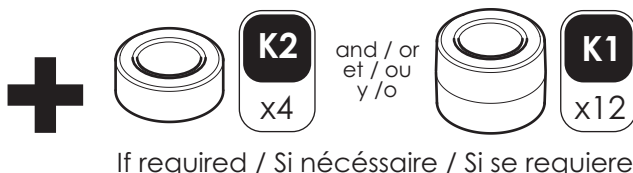
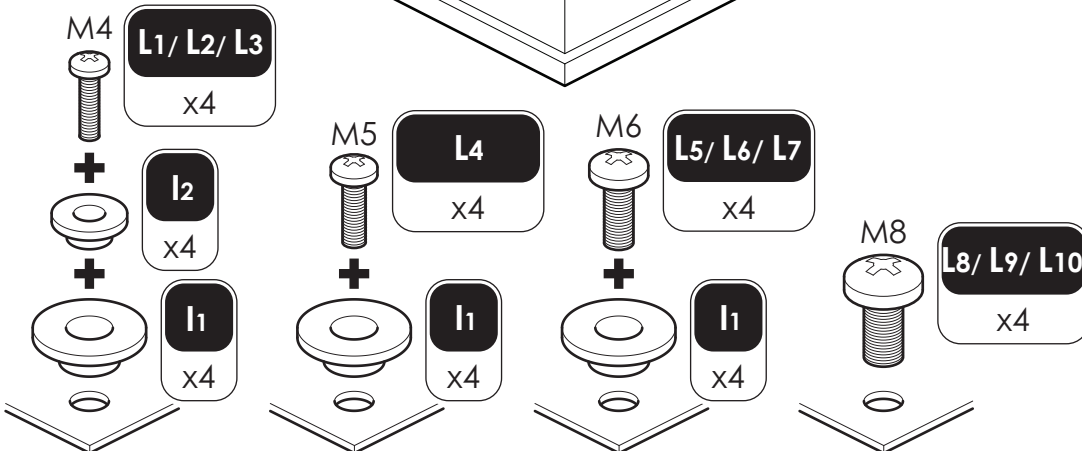

12

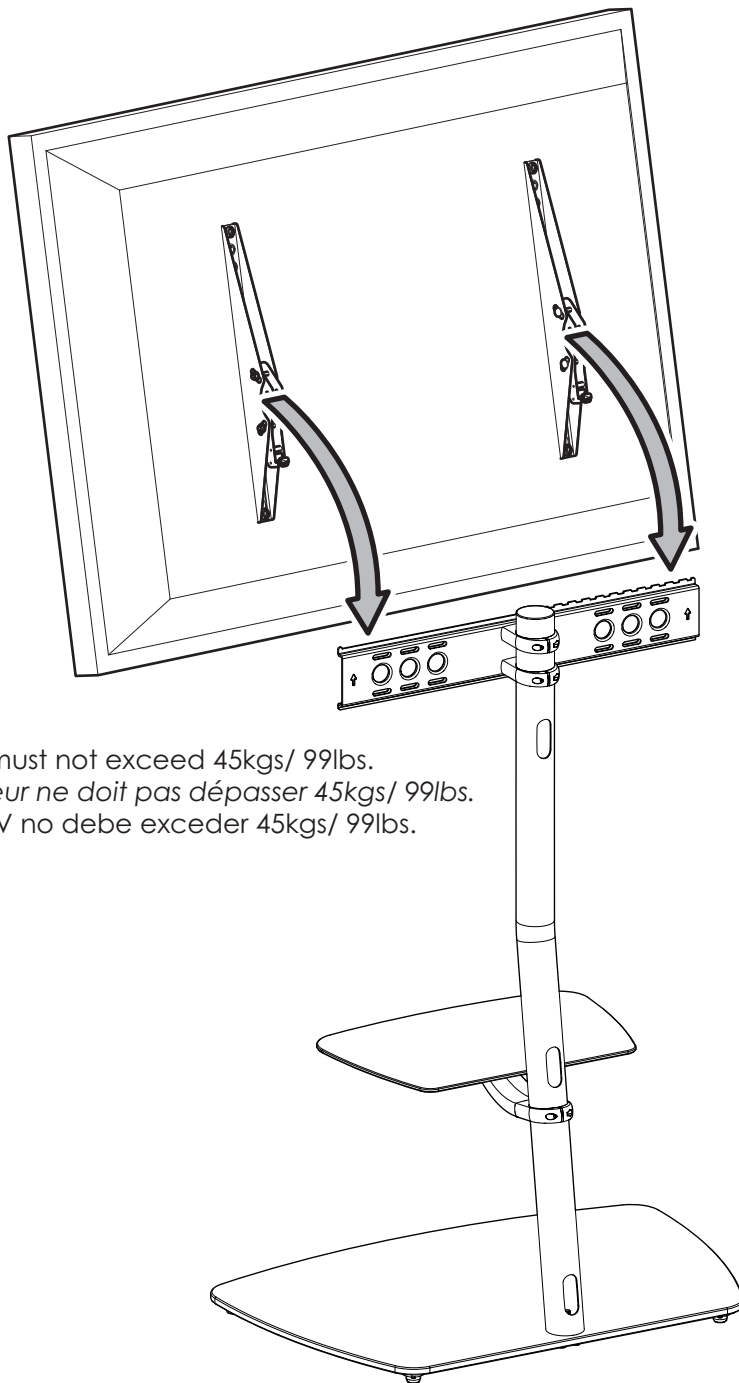

TV weight must not exceed 45kgs/ 99lbs.
Le poids du téléviseur ne doit pas dépasser 45kgs/ 99lbs.
El peso de la TV no debe exceder 45kgs/ 99lbs.

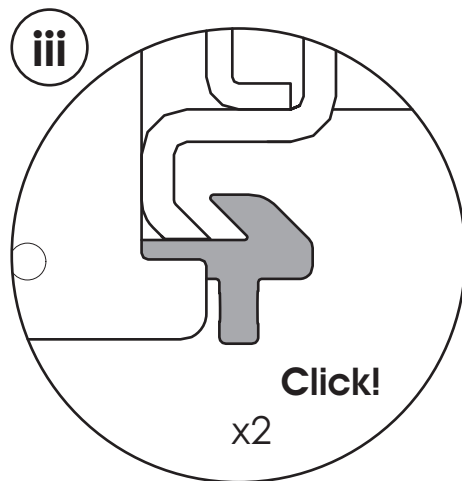
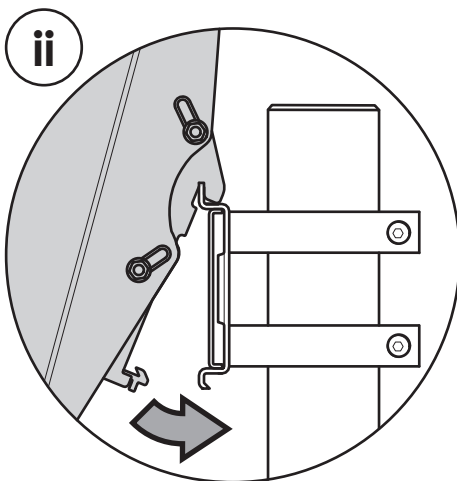
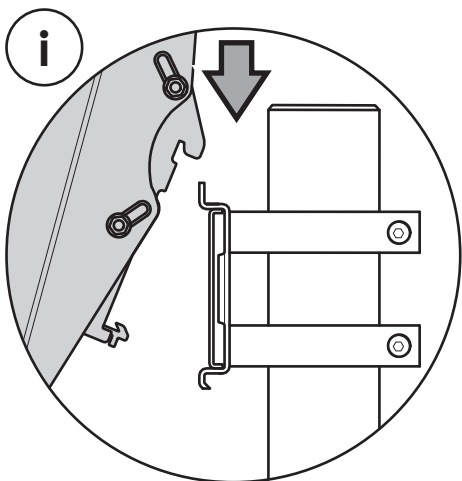

IMPORTANT / IMPORTANTES / IMPORTANTE
Check all nuts and bolts from time to time.
Vérifiez tous les écrous et les boulons de temps à autre.
Compruebe todos los tornillos y tuercas de vez en cuando.

Assembly Complete
L'assemblage est terminé
Ensamblaje Finalizado

Maximum TV weight and shelf capacities
Poids maximal du téléviseur et capacité de charge de l'étagère
Máximo peso y capacidad del estante de TV

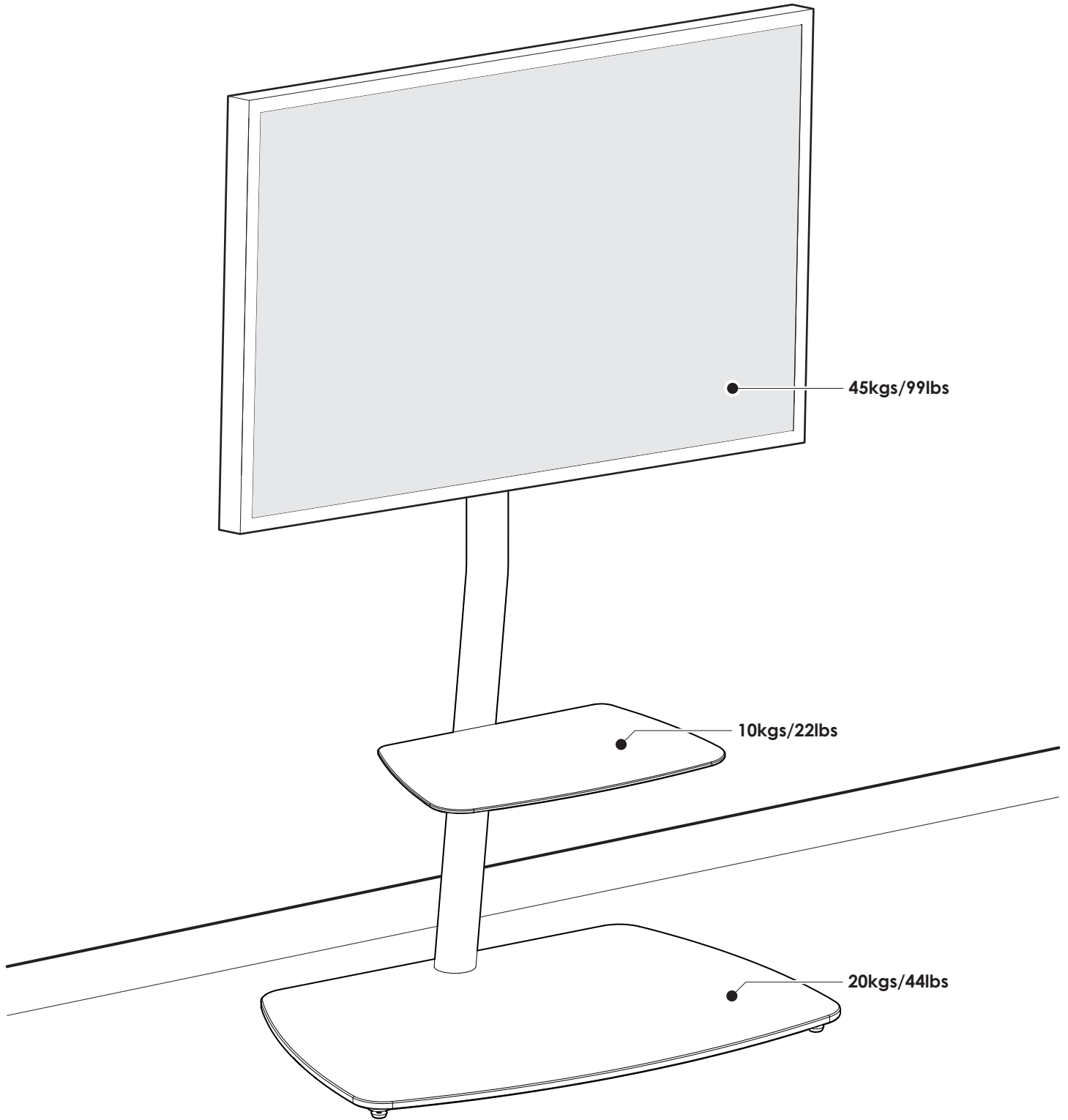

Optional
Optionnel
Opcional

Set tilt resistance if required
Régler la résistance au basculement si nécessaire
Ajustar o aflojar para inclinar de ser necesario

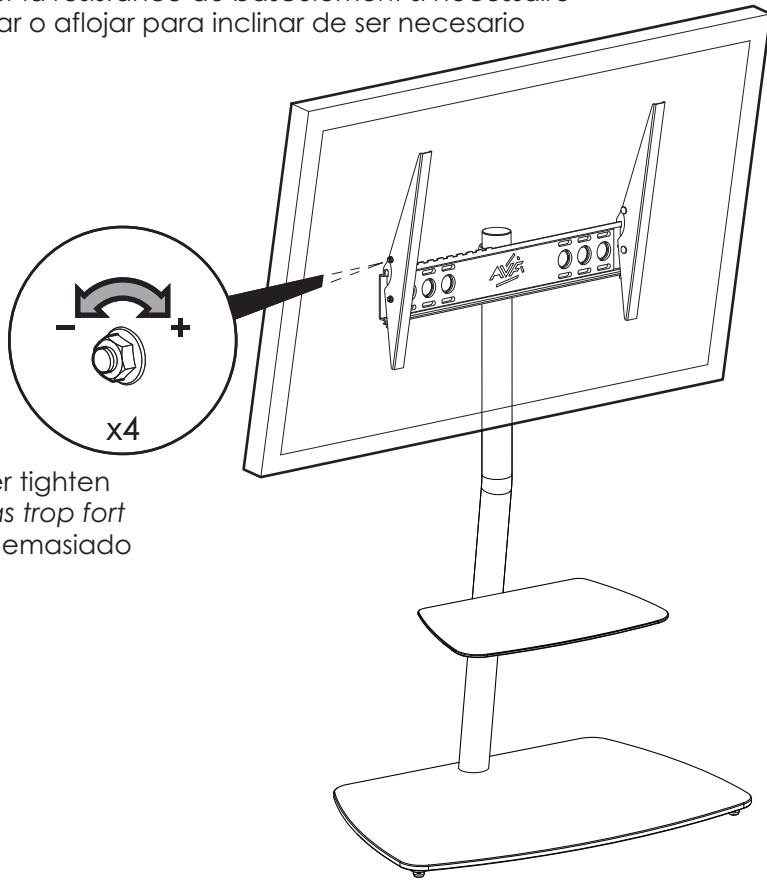

Do not over tighten
Ne serrez pas trop fort
No apriete demasiado

Cable Management
Gestion du câble
Sistema guardacables

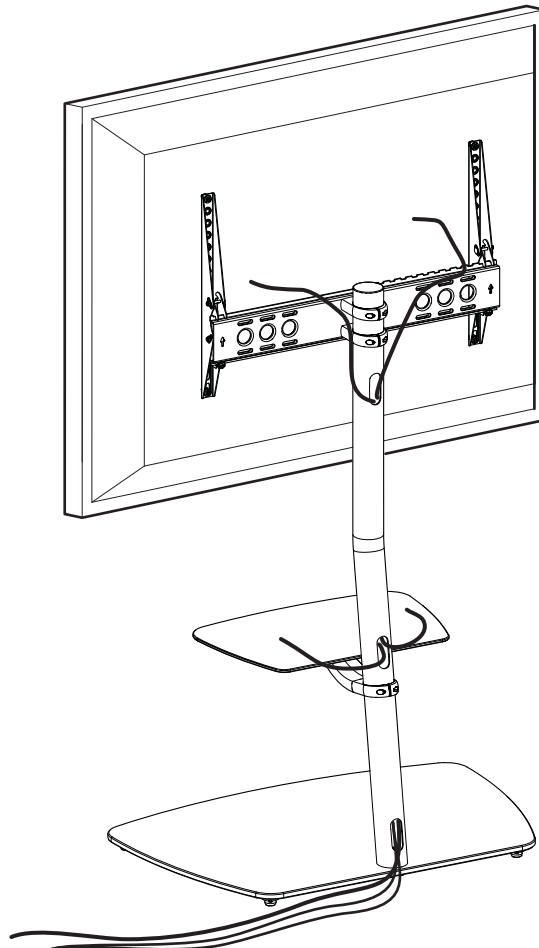

Optional
Optionnel
Opcional

Adjusting Shelf Height
Ajustement de la hauteur de la tablette
Ajuste de la altura del estante

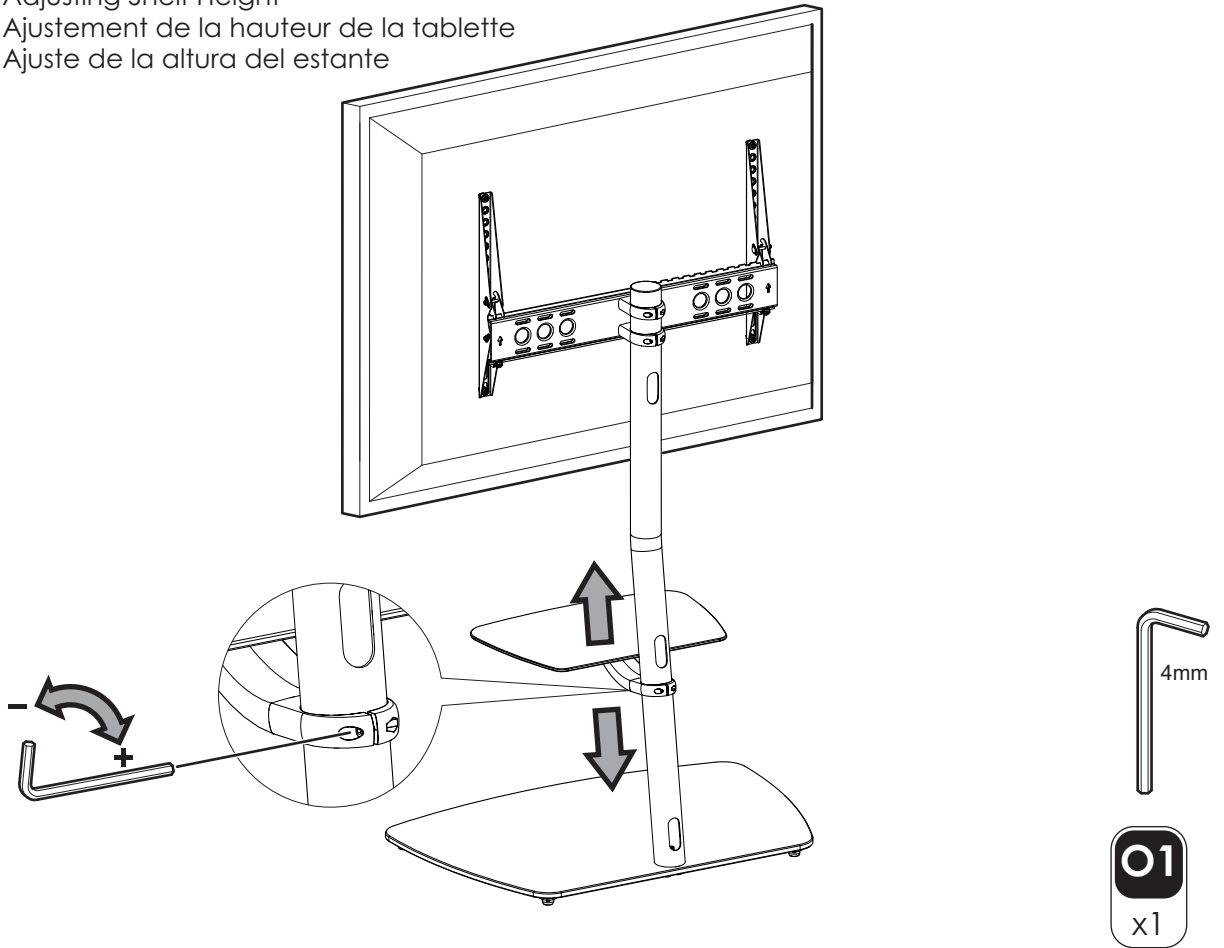

To remove TV
Pour ôter la TV
Para remover la TV

