

CNL655-E

English language / Idioma Español

Leaflet No. / No. de folleto **466044** rev 00

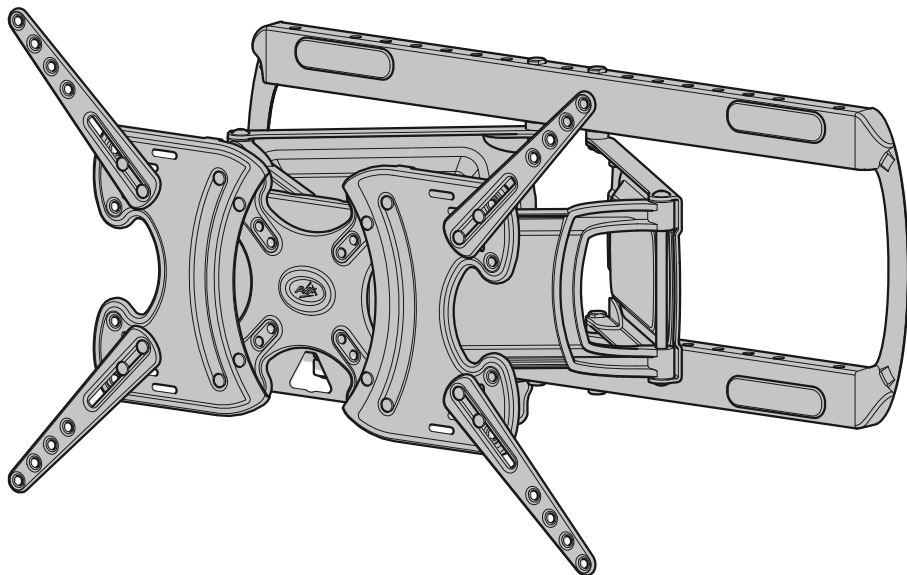

Read through ALL instructions before commencing installation.

If you have any questions about this product or issues with installation contact the customer services help line before returning this product to the store. See www.cmx.avfgroup.com for installation video



Lea todas las instrucciones antes de comenzar la instalación.

Si tiene alguna pregunta sobre el producto o problemas con la instalación. llame a la línea de servicio al consumidor antes de devolverlo. Vea www.cmx.avfgroup.com para el video de instalación



SOPORTE PARA TV DE PANEL PLANO

ITM. / ART. 1040702 • Modelo: CNL655-E

Para televisores de 76 cm (30 pulg.) a 228 cm (90 pulg.) • Soporta un peso de hasta 68 kg

Herramientas recomendadas:

Detector de Vigas de Madera - Broca para Mampostería 12 mm (15/32") - Broca para Madera 5 mm (3/16")

Tornillos, Reductores y Espaciadores de Televisor:

M4(K1) 16 mm, M4(K2) 25 mm, M5(K3) 16 mm, M5(K4) 25 mm, M6 (K5) 16 mm, M6(K6) 25 mm, M6(K7) 45 mm, M8(K8) 16 mm, M8(K9) 25 mm y M8(K10) 45 mm Puede usar los espaciadores M2 y/o M1 si se requiere. Paso 9: Manejo de cables.

Orificios de Televisor: Ancho mínimo 75 mm máximo 600 mm - Alto mínimo 75 mm máximo 400 mm
(Teléfono de Servicio al Cliente no válido en México)

Importado por: Importadora Primex, S.A. de C.V., Blvd. Magnocentro No. 4 San Fernando La Herradura, Huixquilucan, Estado de México, C.P. 52765, RFC: IPR-930907-570, Tel: (55) 5246-5500, www.costco.com.mx

!
Do Not remove
until step 7
No lo quite
hasta llegar
al paso no. 7

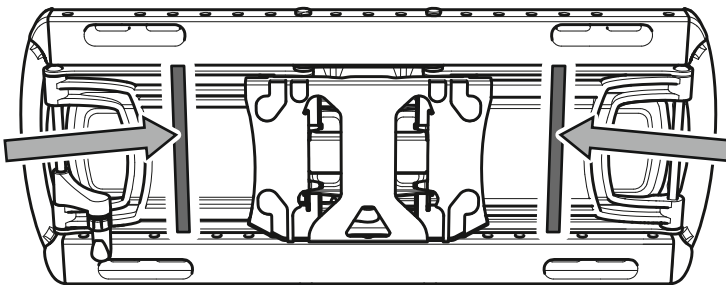

!
Do Not remove
until step 7
No lo quite
hasta llegar
al paso no. 7

Assembly Overview Ensambladura General



2 Person Installation Recommended
Instalación De 2 Personas Recomendado

Determine your TV position
Determine la posición de su TV

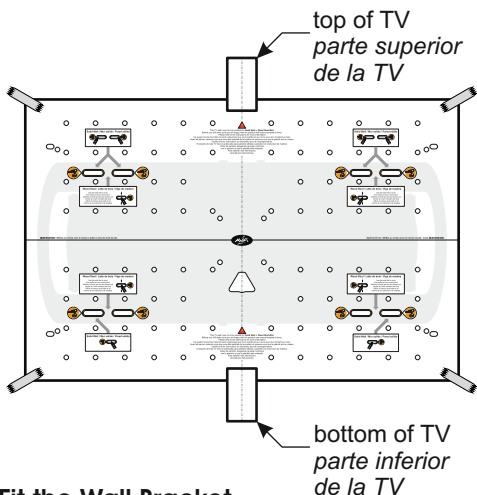

Fit the Wall Bracket
Fije el Soporte de Pared

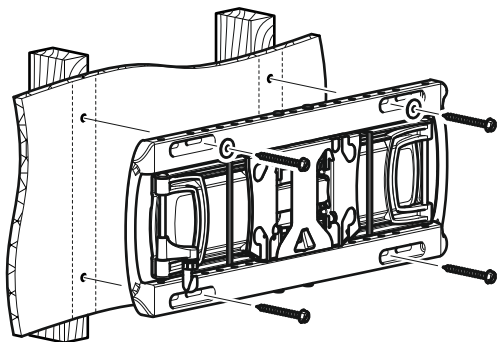

Fit the TV Mounting Plate
Fije La Placa De Montaje De TV

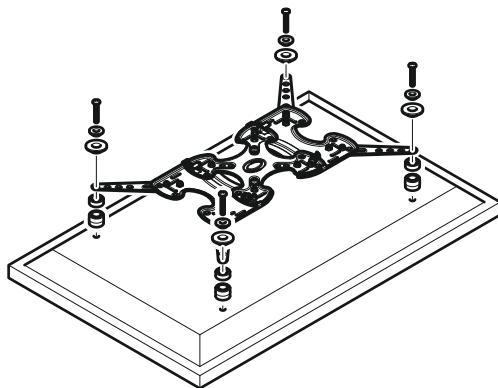

Connect the TV
Conecte la TV

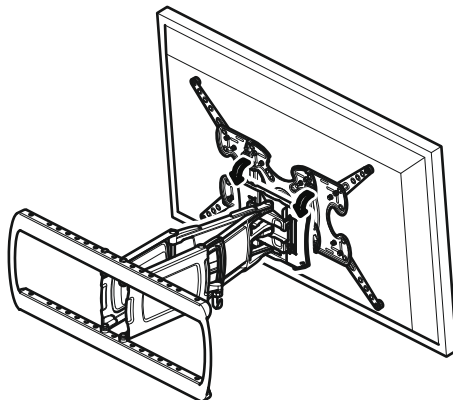

Index Índice

1 Measure the TV fixing holes Width and Height
Mida los orificios de su TV, lo ancho y lo alto

2 Preparing the Front Adaptor Plate
Preparando La Placa Adaptadora Frontal

3 Preparing the TV Mounting Plate
Preparando La Placa De Montaje De TV

4 Determine your TV position
Determine la posición de su TV

5 Fitting the TV Mounting Plate
Fijando La Placa De Montaje De TV

6 Fitting the Wall Bracket
Fijando la Placa a la Pared

7 Fitting the Wall Bracket Covers
Fijando Las Cubiertas Del Soporte De Pared

8 Connecting the TV
Conectando la TV

9 Cable Management
Manejo de Cable

Retain all packaging in case the bracket needs to be returned.

Contents may vary from photography/ Illustrations.

You will not need all these parts, so expect there to be some left over depending upon the specification of your TV.

This product is intended for indoor use only. Use of this product outdoors could lead to failure and personal injury.

It is the responsibility of the installer to ensure that the mounting wall is of a suitable standard and void of any services (eg gas, electricity, water etc).

AVF accept no responsibility for any damage or loss caused by installing this product in a sub standard wall.

Conserve todos los envasados en caso de que el soporte tenga que ser devuelto.

El contenido puede variar de la fotografía / ilustración.

No necesitará todas estas partes, espere que sobren algunas según las especificaciones de su TV.

Este producto está diseñado para el uso en el interior solamente. El uso de este producto en el exterior podría llevar al fracaso y lesiones personales.

Es la responsabilidad del instalador de asegurarse de que la pared de montaje es de un nivel adecuado y carece de todo los servicios (gas, electricidad, agua, etc.).

AVF no acepta ninguna responsabilidad por cualquier daño o pérdida causada por la instalación de este producto en una pared inadecuada.

Tools Recommended
Herramientas recomendadas

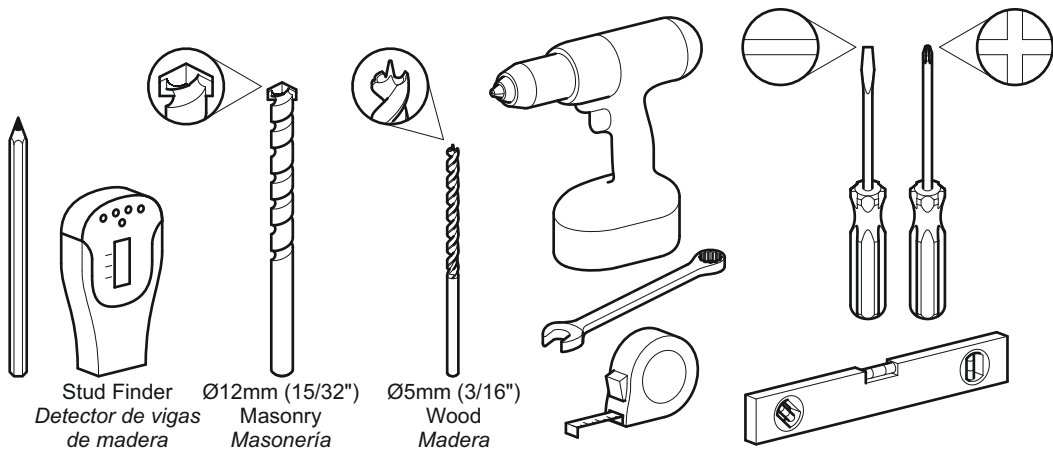

Boxed Parts
Piezas en la Caja

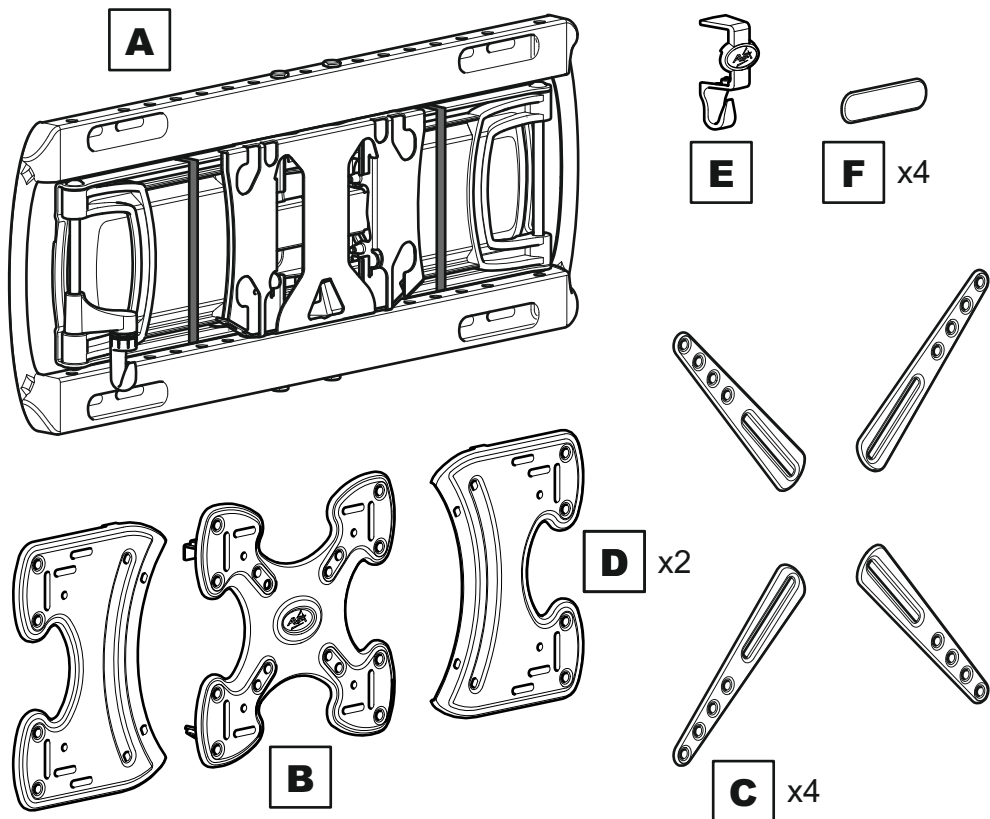

TV Screws, Reducers and Spacers

Tornillos, Reductores y Espaciadores para TV



L1 x4



L2 x4



M1 x12



M2 x4

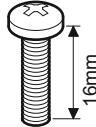

M4
K1 x4

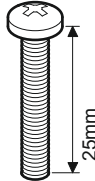

M4
K2 x4

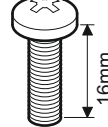

M5
K3 x8

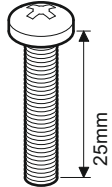

M5
K4 x4

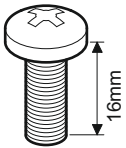

M6
K5 x4

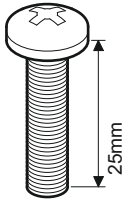

M6
K6 x4

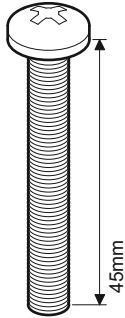

M6
K7 x4

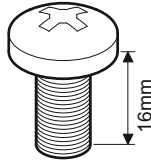

M8
K8 x4

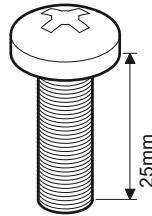

M8
K9 x4

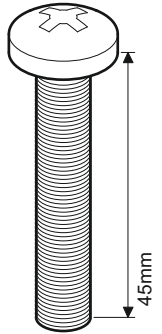

M8
K10 x4



G x16



H x16



I x16



J x8

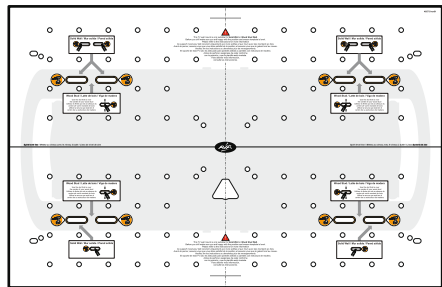

R1



N x6



O x2

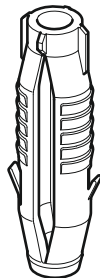

P x6

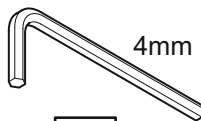

Q x1



R2

1 Measure the TV fixing holes Width and Height Mida los orificios de su TV, lo ancho y lo alto

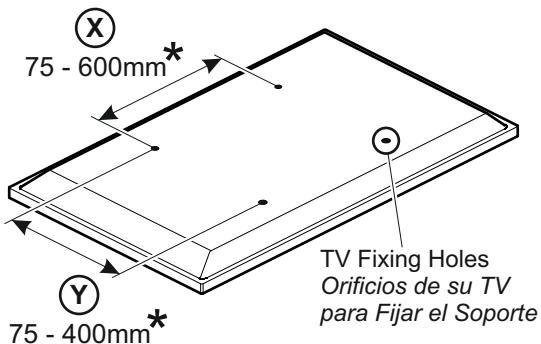

If width (X) is greater than 600mm* or height (Y) greater than 400mm* STOP installation now and contact the customer help line

Si la anchura (X) es mayor que 600mm* o la altura de (Y) es mayor que 400mm* DETENGA la instalación inmediatamente y póngase en contacto con la línea de ayuda al cliente

*Also fits TV fixing holes / También ajusta en los orificios de fijación de la TV

(X) 630mm	(Y) 310mm	(X) 650mm	(Y) 320mm	(X) 660mm	(Y) 320mm
-----------	-----------	-----------	-----------	-----------	-----------

You are provided with 4 diameters of TV fixing screws, **M4**, **M5**, **M6** and **M8**. Determine the screw diameter that fits and remember for step 5.

Se le proporciona con 4 diámetros de tornillos de fijación para su TV: **M4**, **M5**, **M6** y **M8**.

Determine el diámetro del tornillo que le quede a su TV y recuérdelo para el paso 5.

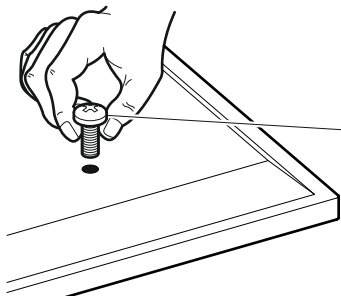

M4 = K1/K2

M5 = K3/K4

M6 = K5-K7

M8 = K8-K10



After completing step 5 you will have fittings left over, please keep for future reference
Después de completar el paso 5 usted tendrá conexiones sobrantes, por favor guarde para futura referencia.

2 Preparing the Front Adaptor Plate Preparando La Placa Adaptadora Frontal

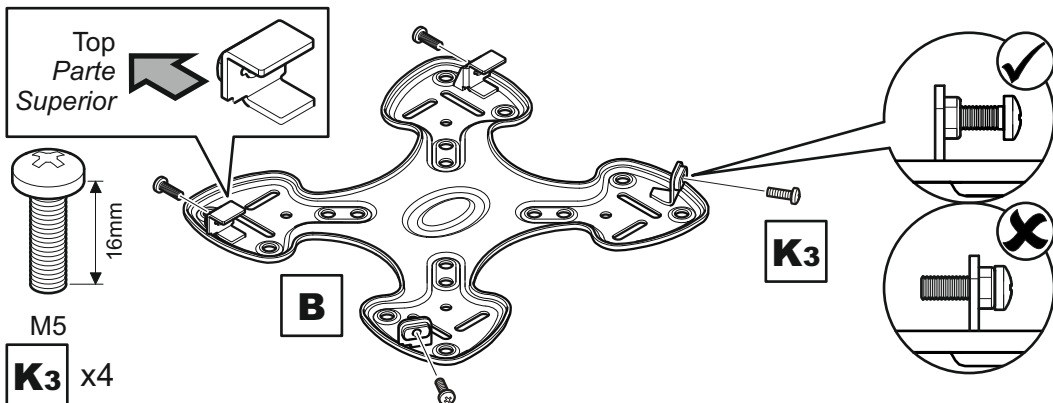

3

Preparing the TV Mounting Plate Preparando La Placa De Montaje De TV

Use the option that fits your TV / *Utilice la opción que mejor se adapte a su TV*
Do not fully tighten / *No ajuste completamente*

OPTION 1 / OPCIÓN 1

- | | |
|--|-----------------------------|
| <input checked="" type="radio"/> 75mm | <input type="radio"/> 75mm |
| <input checked="" type="radio"/> 100mm | <input type="radio"/> 100mm |
| <input checked="" type="radio"/> 200mm | <input type="radio"/> 100mm |
| <input checked="" type="radio"/> 200mm | <input type="radio"/> 200mm |

OPTION 2 / OPCIÓN 2

- | | |
|---|--------------------------------|
| <input checked="" type="radio"/> 300mm | <input type="radio"/> 100mm |
| <input checked="" type="radio"/> 300mm | <input type="radio"/> 200mm |
| <input checked="" type="radio"/> 300mm | <input type="radio"/> 300mm |
| <input checked="" type="radio"/> 400mm | <input type="radio"/> 100mm |
| <input checked="" type="radio"/> 400mm | <input type="radio"/> 200mm |
| <input checked="" type="radio"/> 400mm | <input type="radio"/> 300mm |
| <input checked="" type="radio"/> 400mm | <input type="radio"/> 400mm |
| <input checked="" type="radio"/> 75-400mm | <input type="radio"/> 75-400mm |

OPTION 3 / OPCIÓN 3

- | | |
|--|--------------------------------|
| <input checked="" type="radio"/> 600mm | <input type="radio"/> 100mm |
| <input checked="" type="radio"/> 600mm | <input type="radio"/> 200mm |
| <input checked="" type="radio"/> 600mm | <input type="radio"/> 300mm |
| <input checked="" type="radio"/> 600mm | <input type="radio"/> 400mm |
| <input checked="" type="radio"/> 400-600mm | <input type="radio"/> 75-400mm |
| <input checked="" type="radio"/> 630mm | <input type="radio"/> 310mm |
| <input checked="" type="radio"/> 650mm | <input type="radio"/> 320mm |
| <input checked="" type="radio"/> 660mm | <input type="radio"/> 320mm |

If in any doubt please call the customer help line.

Si tiene alguna duda, comuníquese con la línea de atención al cliente.

OPTION 1 / OPCIÓN 1

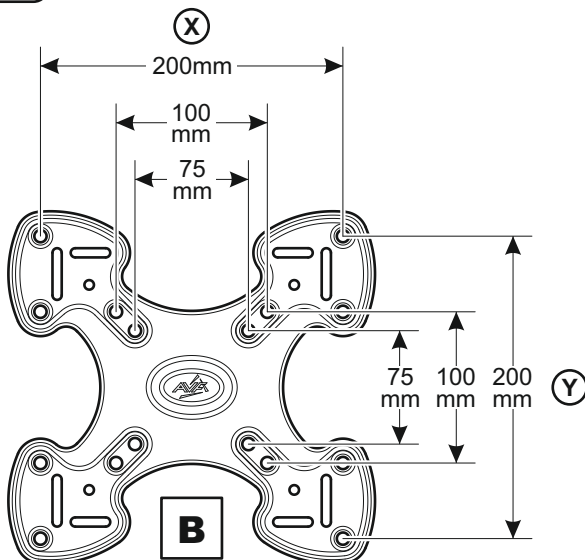

If your TV fixing holes match any of the sizes shown above you will not need to use any adaptors. Please go to step 4.

Si los orificios de ajuste de TV coinciden con cualquiera de los tamaños que se indican arriba, no necesitará utilizar adaptadores. Continúe con el paso 4

OPTION 2 / OPCIÓN 2



When attaching adaptors **C** you must always use **HOLES x4** and either of the **SLOTS**.

*Para colocar adaptadores **C** deberá siempre utilizar **ORIFICIOS x4** y alguna de las **RANURAS**.*

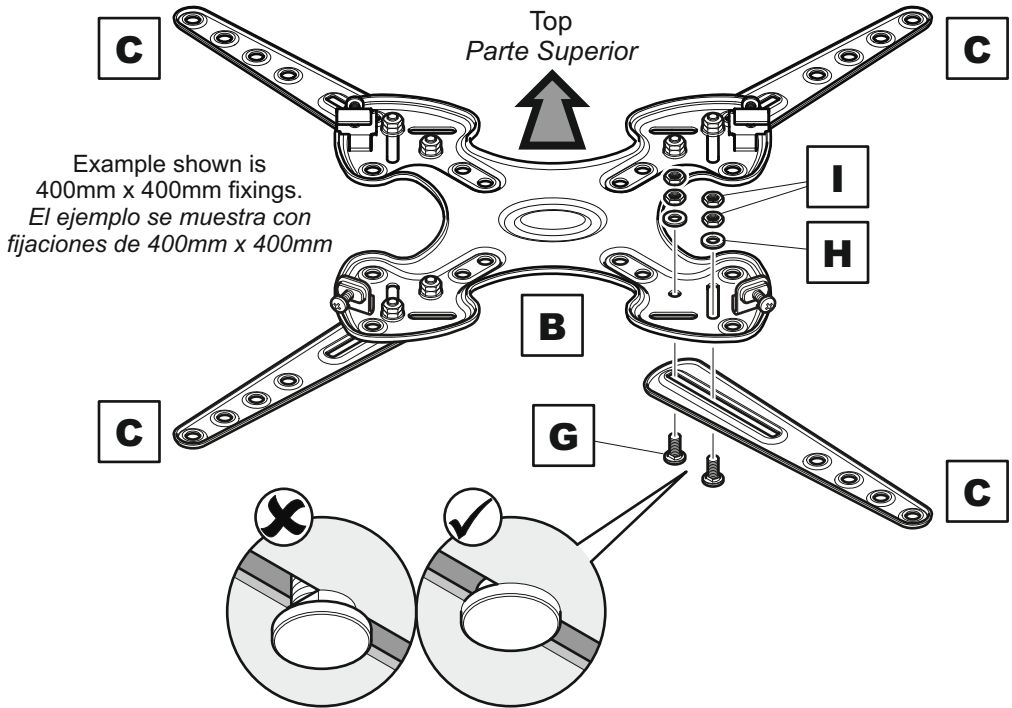
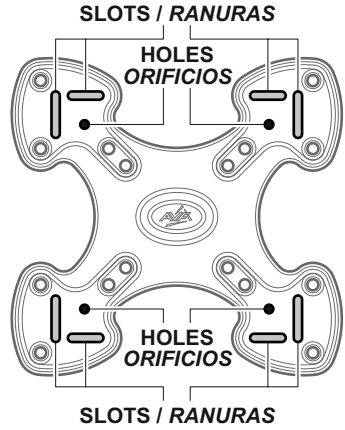

Example shown is 400mm x 400mm fixings.
El ejemplo se muestra con fijaciones de 400mm x 400mm

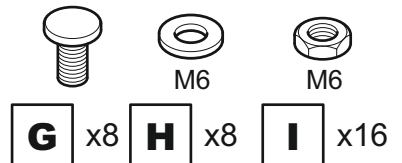

● = HOLES / ORIFICIOS
○ = SLOTS / RANURAS

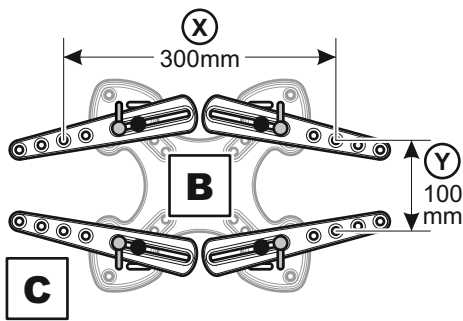
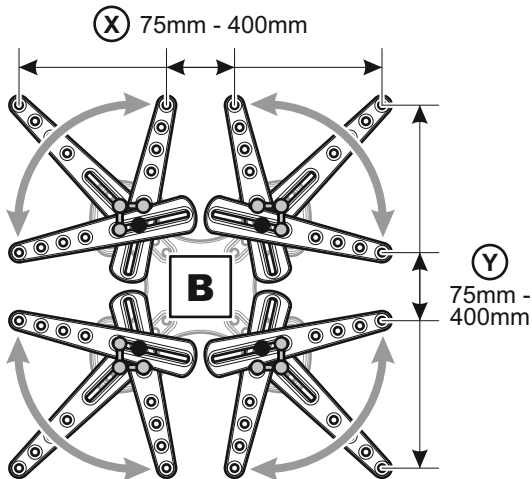

C

Adaptors **C** can be fixed in different positions in the slots on Plate **B** to match your TV fixing holes.
*Los adaptadores **C** pueden fijarse en diferentes posiciones en las ranuras de la placa **B** para que coincidan con los orificios de fijación de su televisor.*

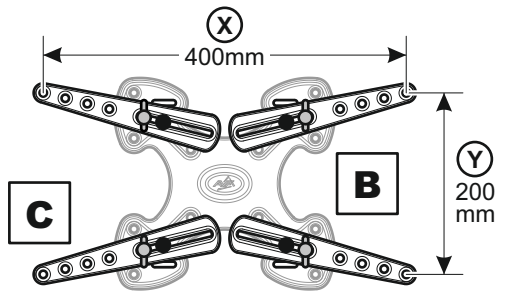
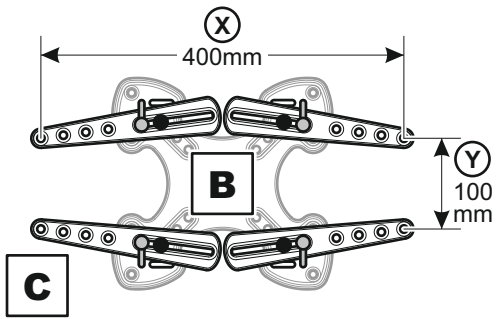
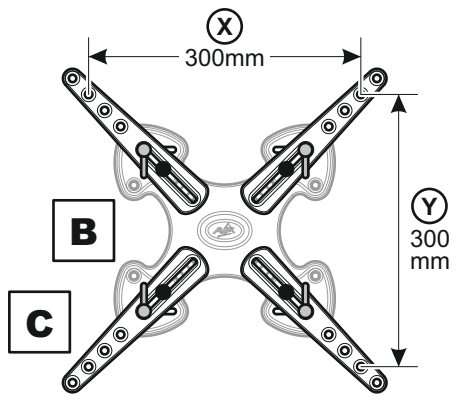
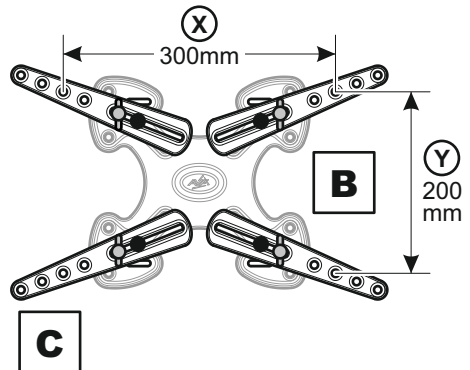

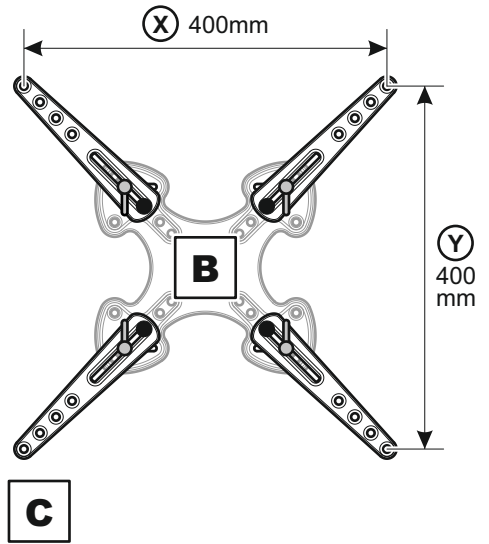
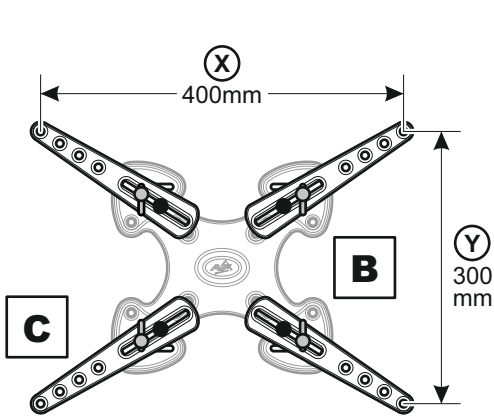

● = HOLES / ORIFICIOS
○ = SLOTS / RANURAS

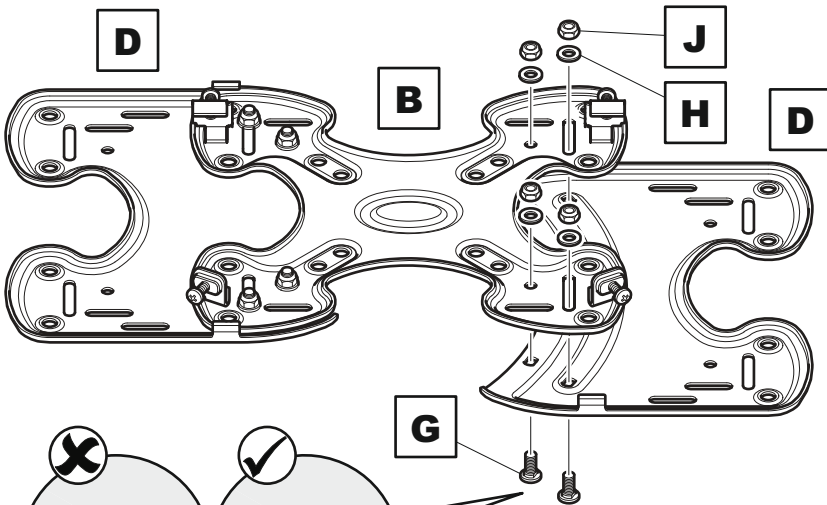

OPTION 3 / OPCIÓN 3



- 
G x8
- 
H x8
- 
J x8



When attaching adaptors **C** you must always use **HOLES x4** and either of the **SLOTS**.
*Para colocar adaptadores **C** deberá siempre utilizar **ORIFICIOS x4** y alguna de las **RANURAS**.*

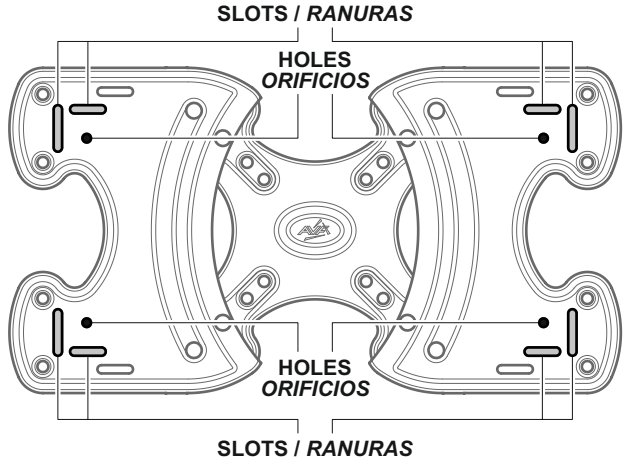

Example shown is 600mm x 400mm fixings.
El ejemplo se muestra con fijaciones de 600mm x 400mm

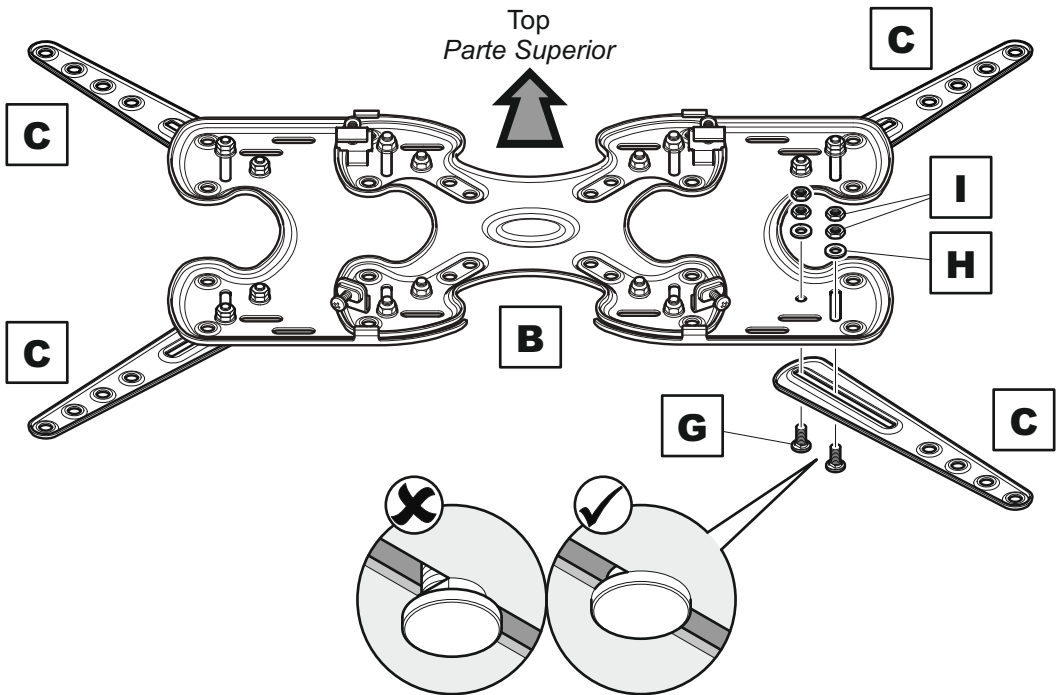

G x8

H x8

I x16

- = HOLES / ORIFICIOS
- = SLOTS / RANURAS

Adaptors **C** can be fixed in different positions in the slots on Plate **B** to match your TV fixing holes.

*Los adaptadores **C** pueden fijarse en diferentes posiciones en las ranuras de la placa **B** para que coincidan con los orificios de fijación de su televisor.*

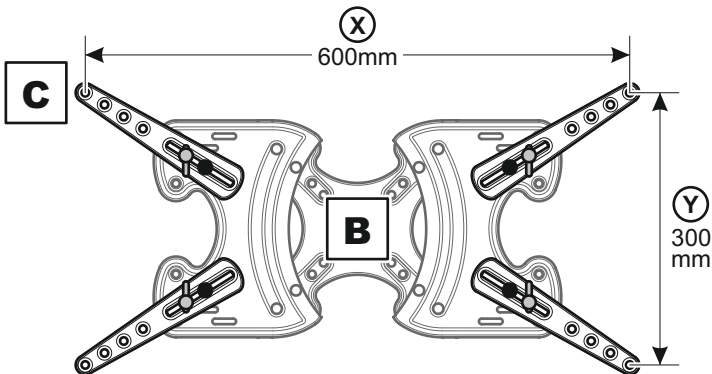
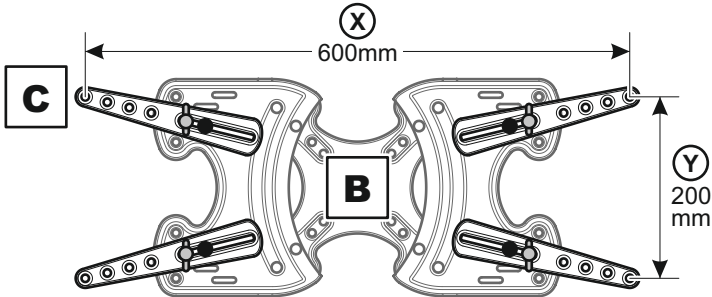
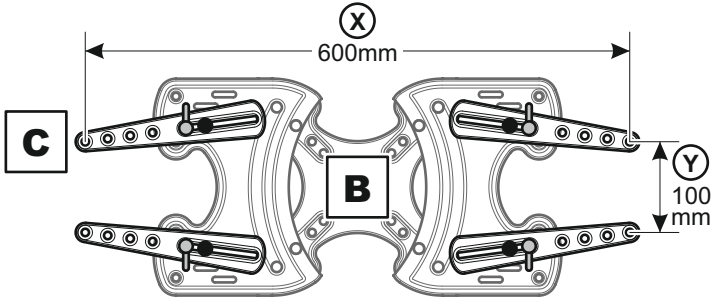
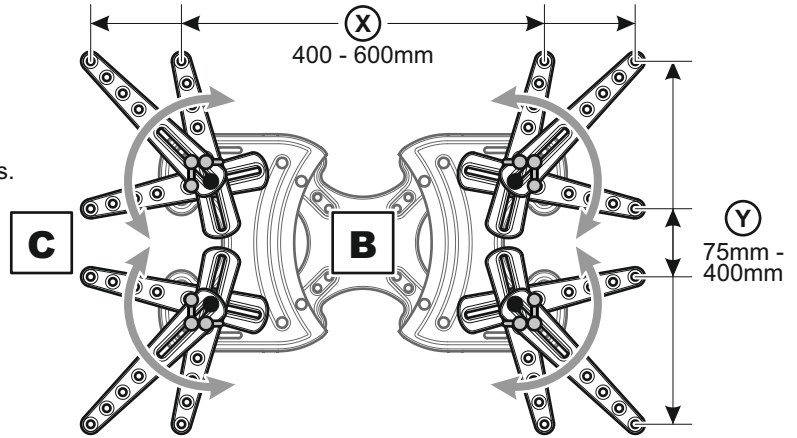

- = HOLES
ORIFICIOS
- = SLOTS
RANURAS

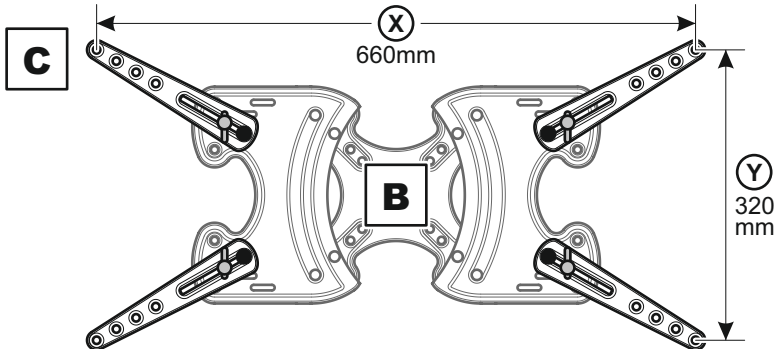
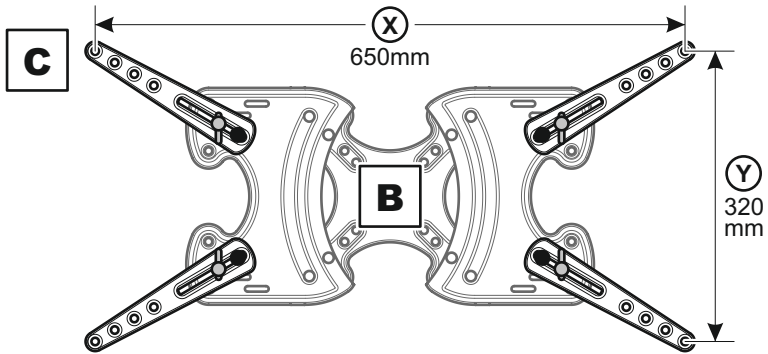
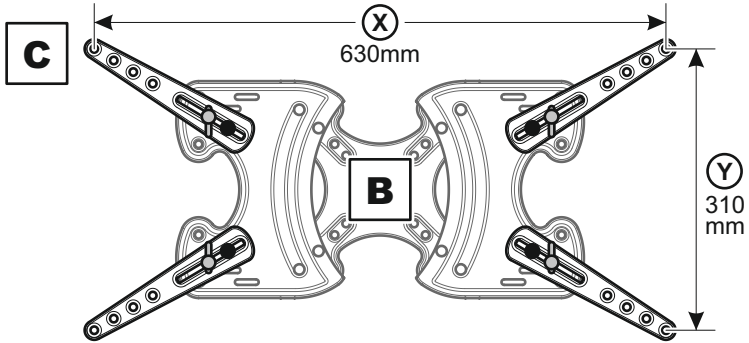
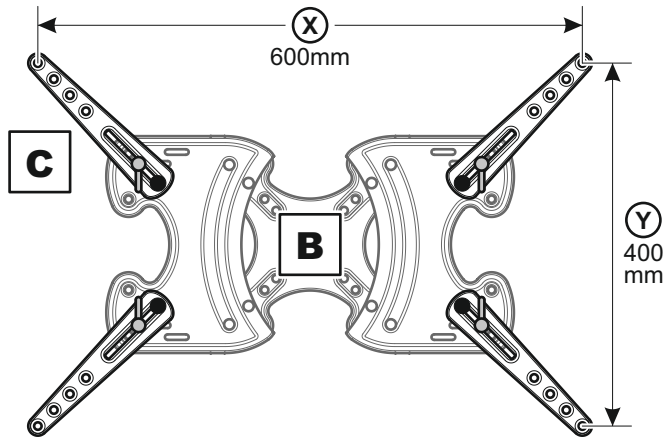

4

Determine your TV position Determine la posición de su TV

Joining templates R1 and R2 will give you a guide that represents the height and center of YOUR TV so you can position YOUR TV perfectly and know exactly where to drill your wall.
Si une las plantillas R1 y R2 obtendrá una idea que representa la altura y el centro de SU TV, por lo cual podrá ubicar SU TV perfectamente y sabrá dónde perforar su pared con precisión



Assemble Positioning Template
Monte la plantilla de posición

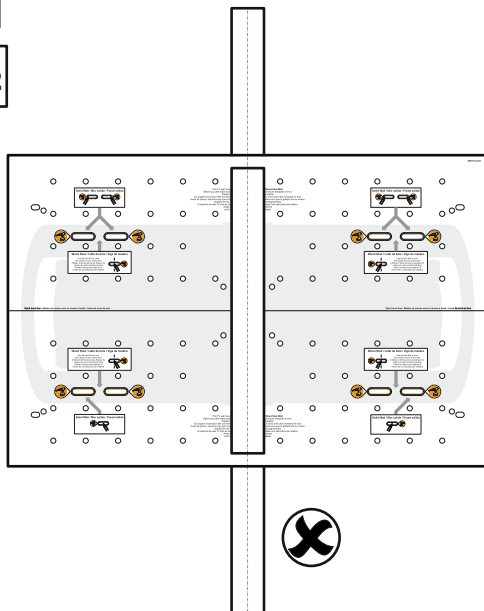
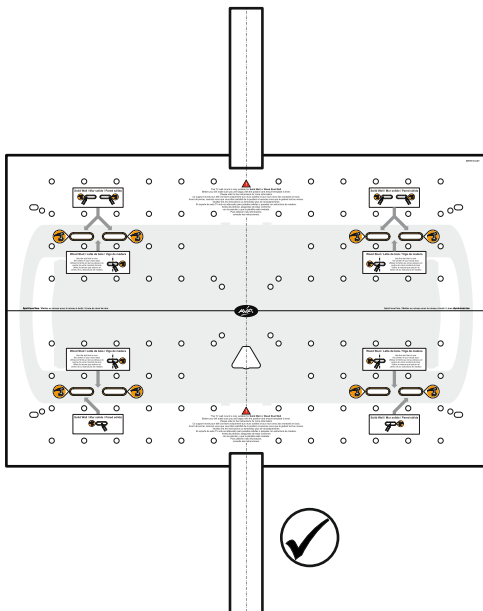
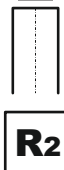
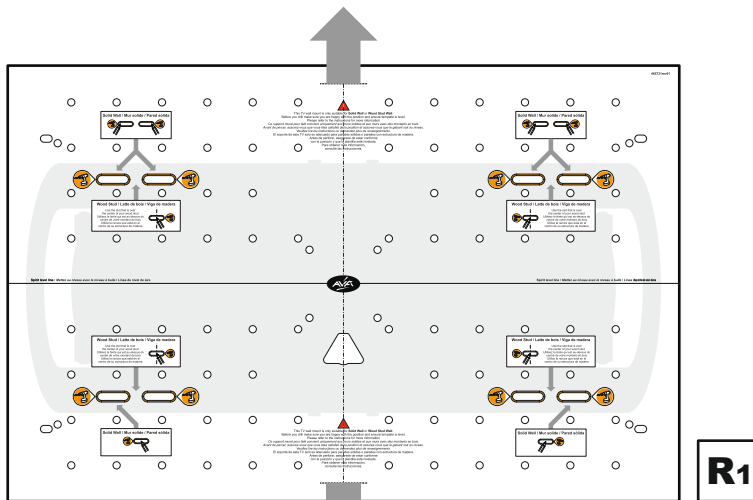



Lay template on the back of the TV as shown in the images below.

Align the fixing holes on the template **R1** with the TV fixing holes on the back of your TV. If your TV has fixing holes that are not shown on the template **R1** simply punch 4 holes that match your TV fixing holes.

*Coloque la plantilla en la parte posterior de la TV como muestran las imágenes a continuación. Nivele los orificios de anclaje en la plantilla **R1** con los orificios de anclaje de la TV en la parte posterior de la misma.*

*Si su TV tiene orificios de anclaje que no figuran en la plantilla **R1**, simplemente perforo 4 orificios que coincidan con los orificios de anclaje de su TV*

Example shown is
600mm x 400mm fixings.
*El ejemplo se muestra con
fijaciones de 600mm x 400mm*

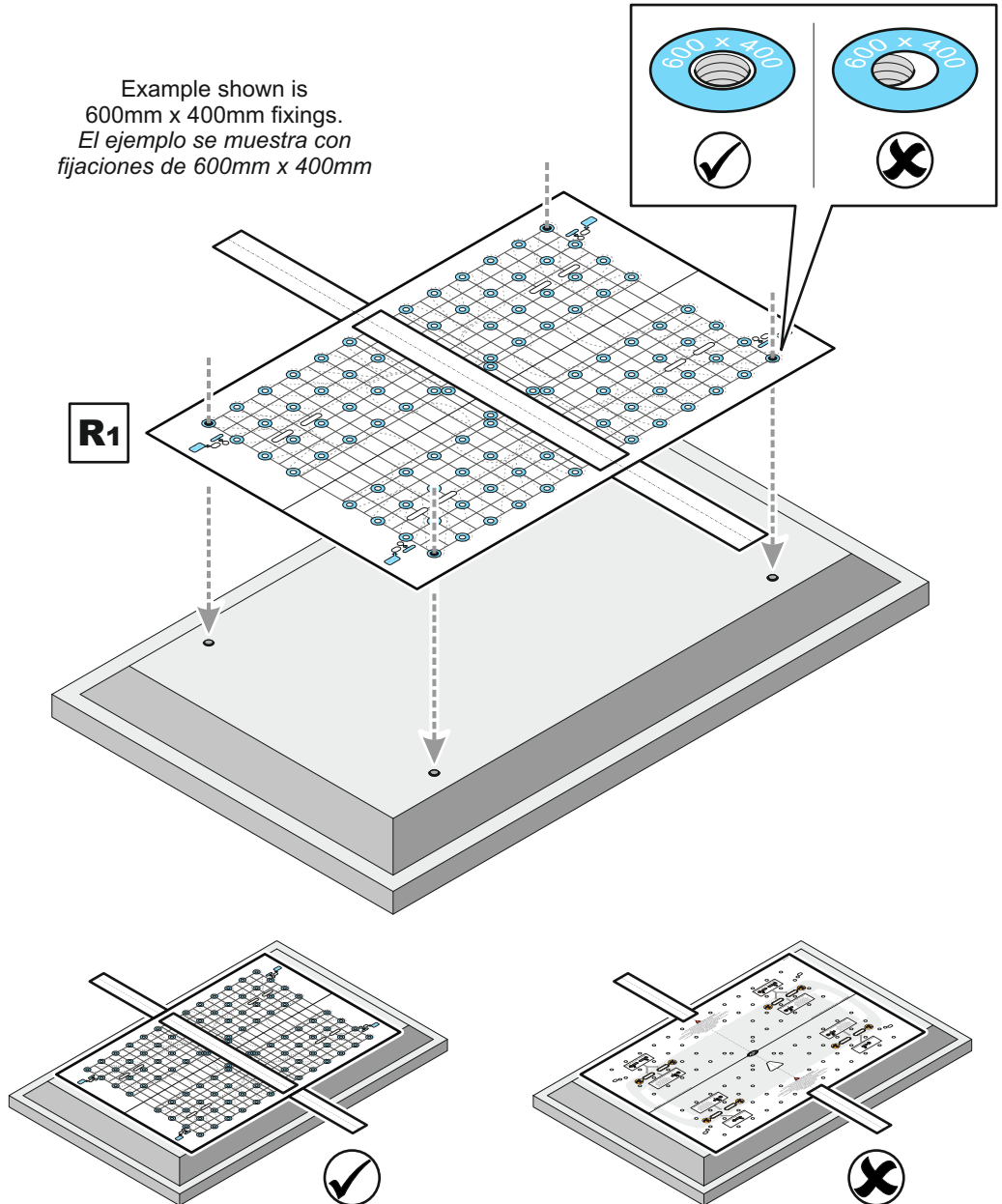



Align template **R2** with the top of your TV and cut so it is flush with the bottom of your TV and stick in position.

*Nivele la plantilla **R2** con la parte superior de su Tv y corte para que quede alineada con la parte inferior de su TV y firme en esa posición.*

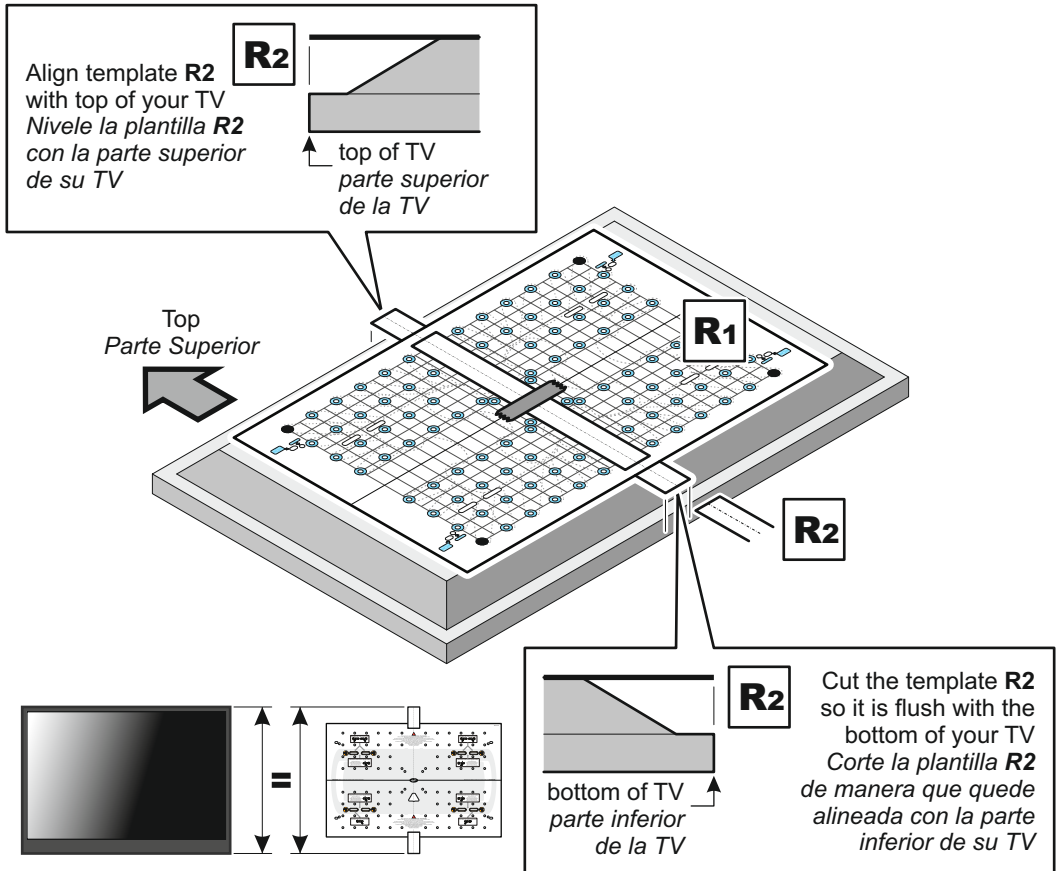

Remove the template from the back of your TV before you continue
Quite la plantilla de la parte posterior de su TV antes de continuar



Use template **R1** and **R2** to determine the position of your TV on the wall.
When you are happy with the position ensure template is level and fix to wall. Before marking the drill points you will need to determine the wall type that you have i.e. **Solid Wall** or **Wood Stud Wall**. Ensure the drilling area is free from mains services (Gas / Electric / Water).

*Use las plantillas **R1** y **R2** para determinar la posición de su TV en la pared. Cuando esté conforme con la posición, asegúrese que la plantilla esté nivelada y quede fija a la pared. Antes de marcar los puntos de perforación, deberá determinar el tipo de pared que tiene; por ej.: **pared sólida** o **pared con estructura de madera**. Asegúrese de que el área de perforación no dañará los servicios de red (gas / electricidad / agua)*

The image below shows the drill points for **Solid Wall** or **Wood Stud Wall** installation.

Solid Wall = 6 drill points

Wood Stud Wall = 4 drill points

*La imagen a continuación muestra los puntos de perforación para la instalación en **pared sólida** o **pared con estructura de madera**.*

Pared sólida = 6 puntos de perforación

Pared con estructura de madera = 4 puntos de perforación

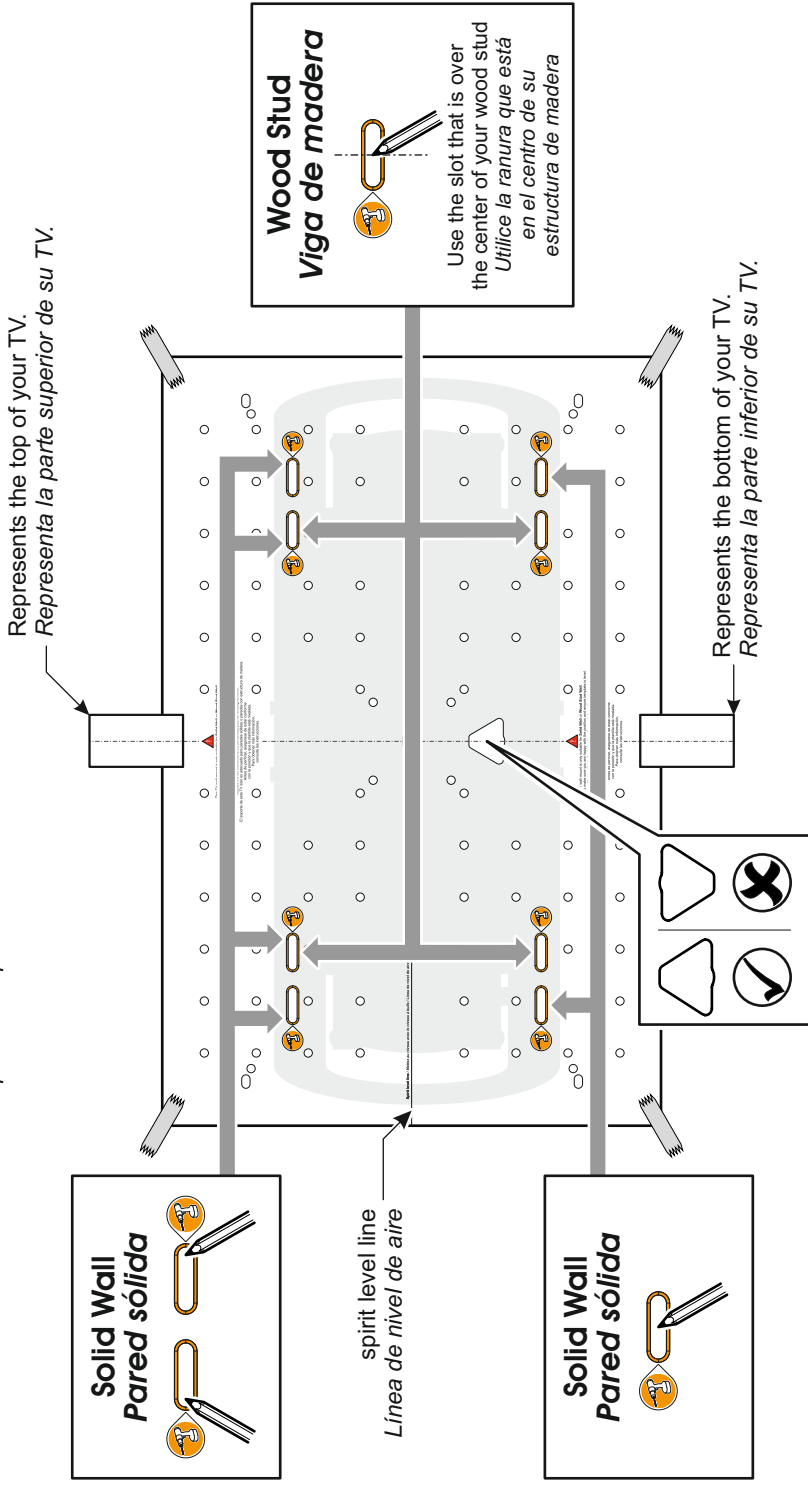

Remove template from wall and continue with installation
Quite la plantilla de la pared y proceda con la instalación



5

Fitting the TV Mounting Plate *Fijando la Placa de Montaje a su TV*

Before you fully tighten the TV mounting plate please check that the mounting plate holes line up with the fixing holes on the back of your TV.

Antes de fijar completamente la placa de montaje de TV verifique que los orificios de la placa de montaje coincidan con los orificios en la parte posterior de su TV

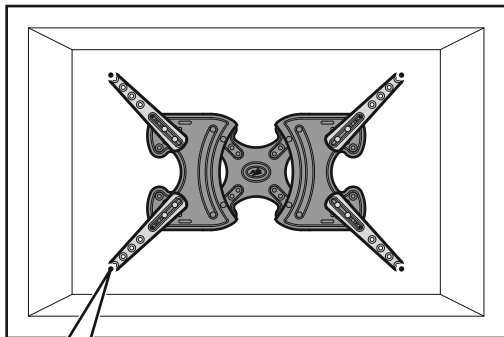

Holes do not line up and small adjustment is required before you fully tighten
Los orificios no coinciden y es necesario hacer un pequeño ajuste antes de fijar completamente

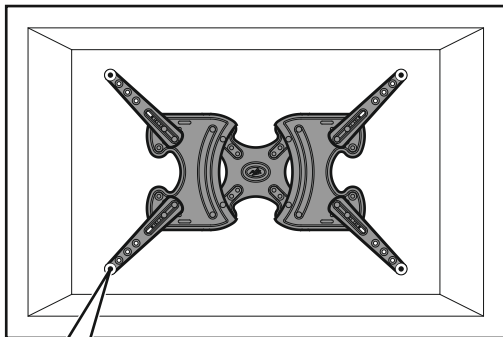

Holes line up and no adjustment is required before you fully tighten
Los orificios coinciden y no es necesario hacer ningún ajuste antes de fijar completamente

No Spacers *Sin espaciadores*

For TVs with flat/
unobstructed back
Para TVs con la parte posterior plana / sin obstáculos

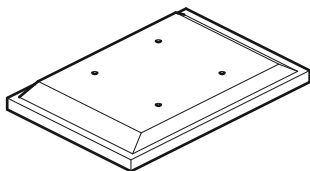

Spacers *Espaciadores* **M1/M2**

For TVs with irregular/obstructed back
Para TVs con la parte posterior irregular / con obstáculos

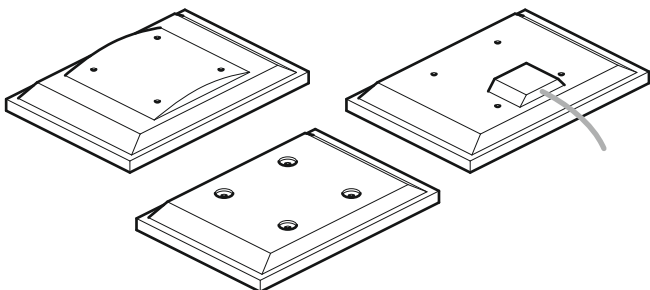

WARNING / ADVERTENCIA

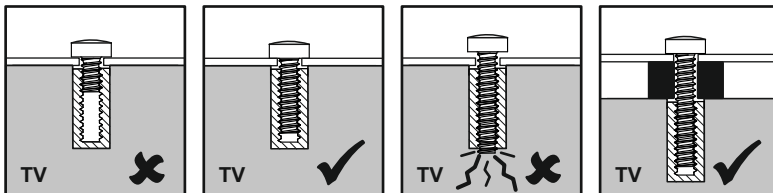

After completing step 5 you will have fittings left over, please keep for future reference.
Después de completar el paso 5 usted tendrá conexiones sobrantes, por favor guarde para futura referencia.

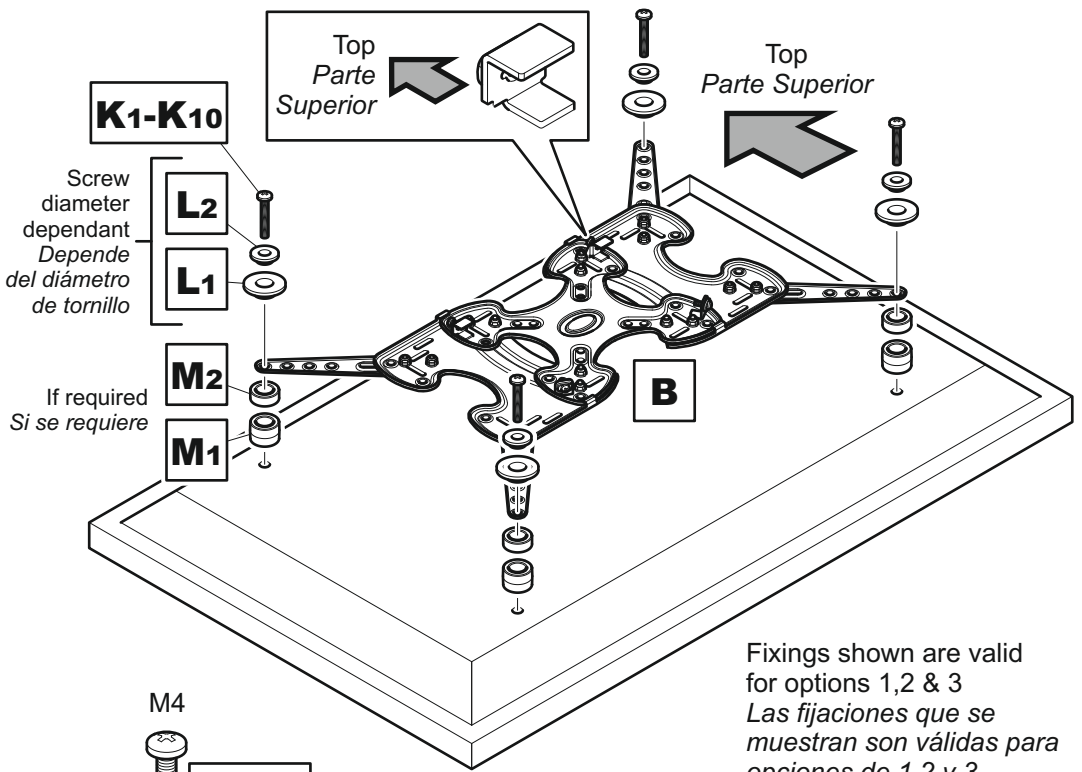

Fixings shown are valid for options 1,2 & 3
 Las fijaciones que se muestran son válidas para opciones de 1,2 y 3

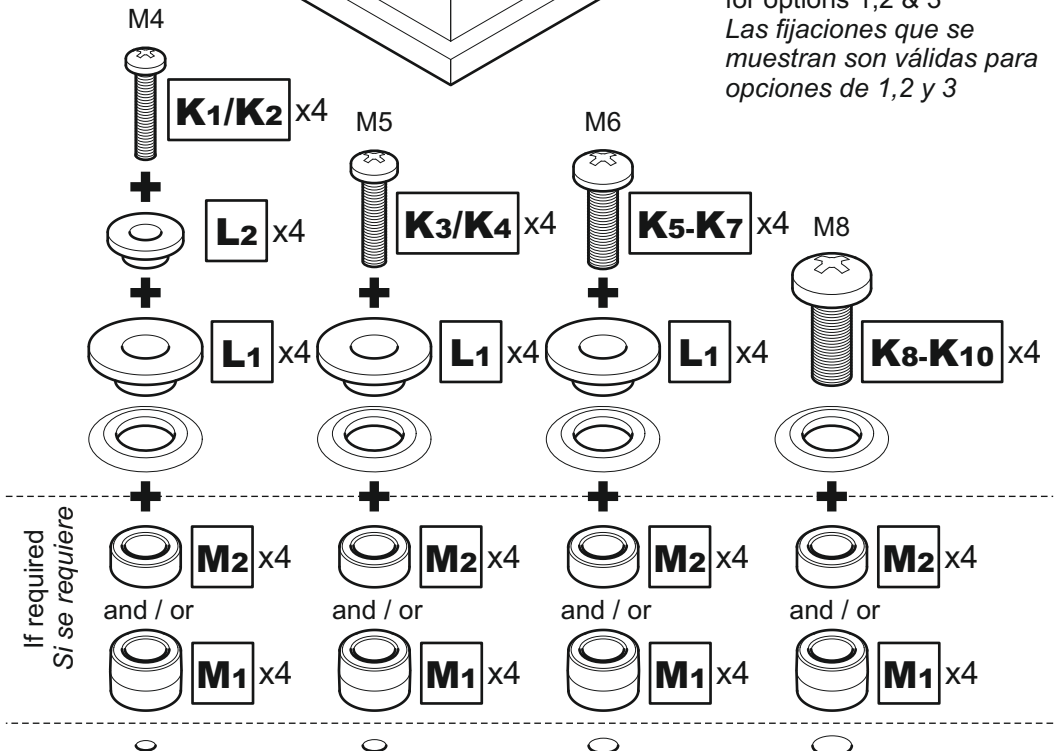

Attach the brackets to the back of your TV using suitable screw, reducer and spacer combinations.
 Coloque los soportes a la parte posterior de su TV usando la combinación adecuada de tornillo, reductor y espaciador.

6 Fitting the Wall Bracket Fijando la Placa a la Pared

Solid Wall / Pared sólida

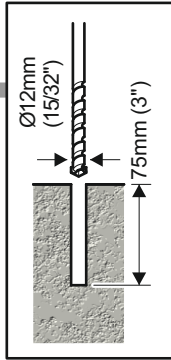
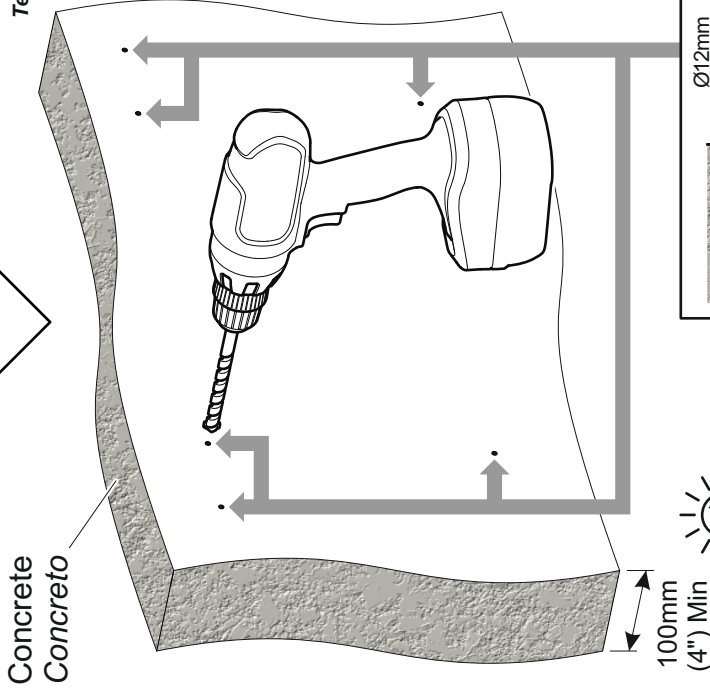

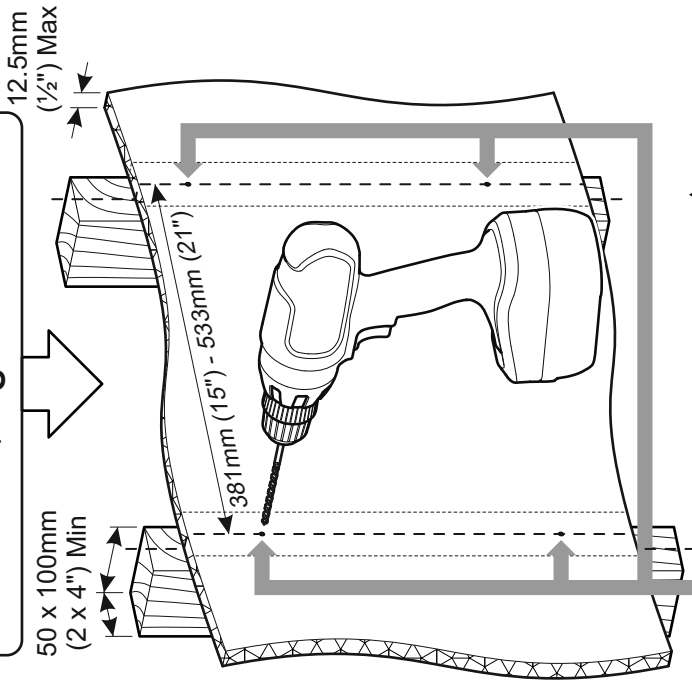

Wood Stud / Viga de madera

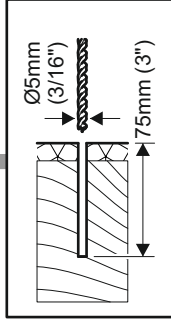

Ensure you drill in the center of the wood stud
Asegúrese de que el soporte está en el centro de la viga de madera

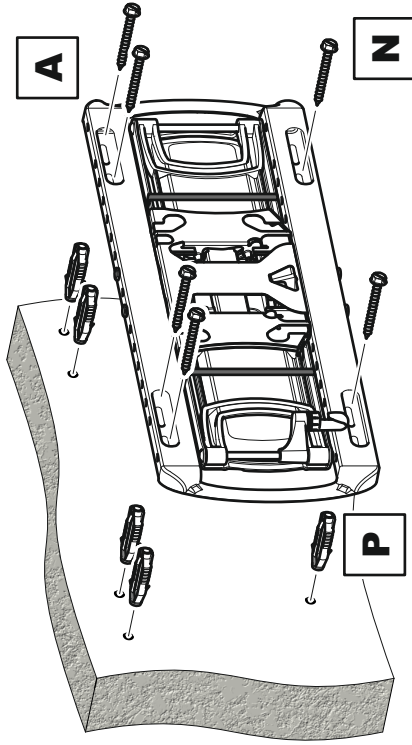
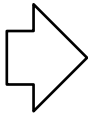



 Lubricate screw
thread with soap
*Lubrique la rosca
del tornillo con jabón*



DO NOT over tighten screws
Tighten screws by hand only
NO sobre apriete los tornillos.
Apriete los tornillos sólo a mano

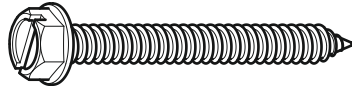

N x6

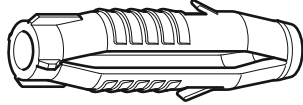

P x6

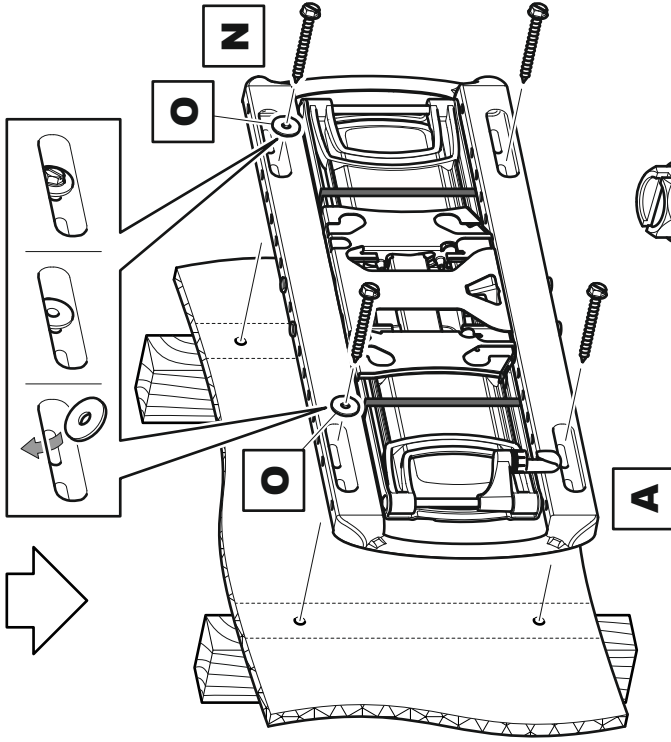
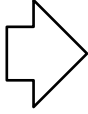

 Lubricate screw
thread with soap
*Lubrique la rosca
del tornillo con jabón*



DO NOT over tighten screws
Tighten screws by hand only
NO sobre apriete los tornillos.
Apriete los tornillos sólo a mano

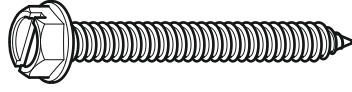

N x4



O x2

7

Fitting the Wall Bracket Covers *Fijando Las Cubiertas Del Soporte De Pared*

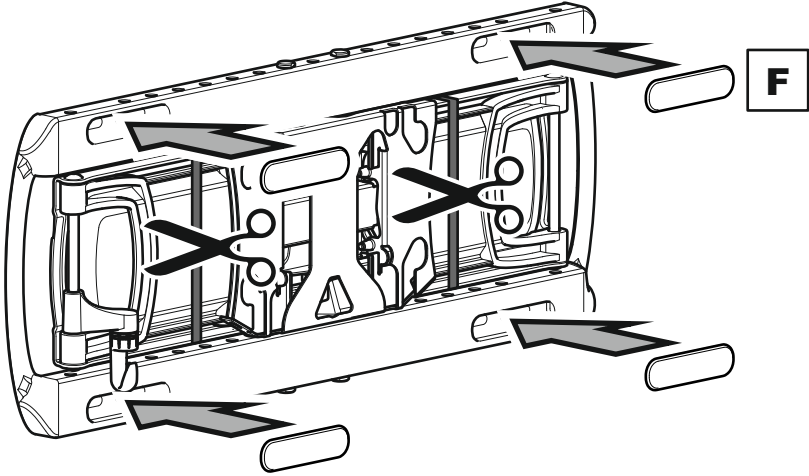
**8**

Connecting the TV *Conectando la TV*

Attaching and Locking
Sujetando y Asegurando

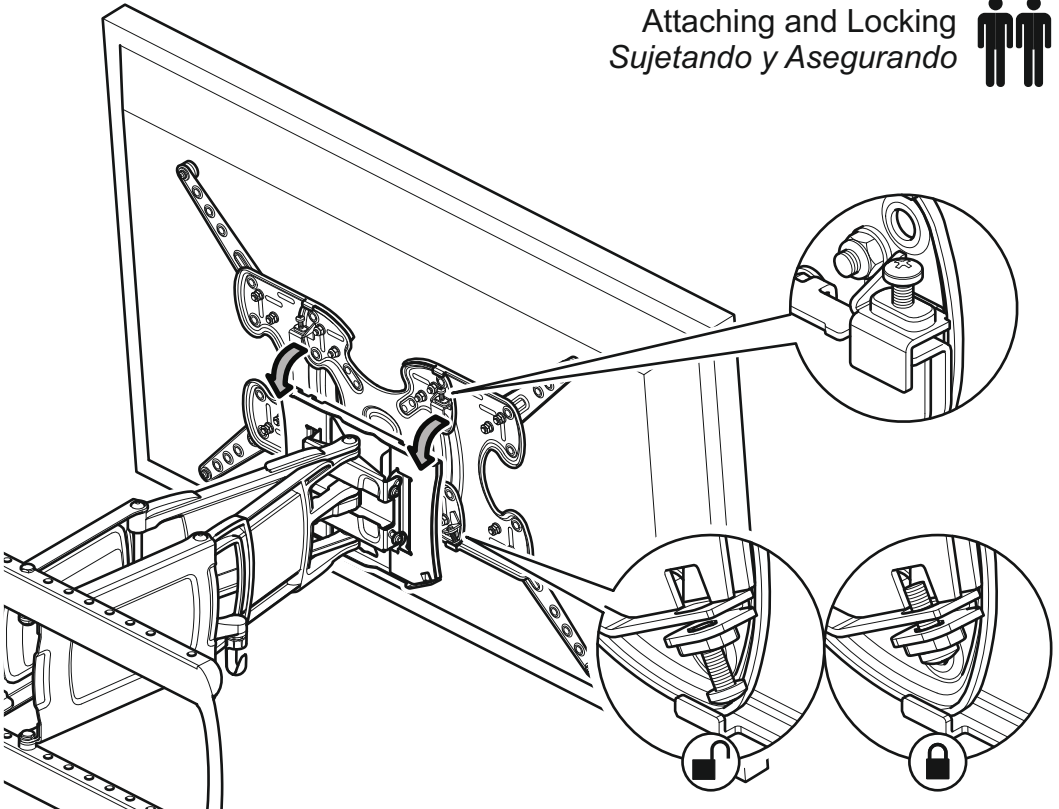

9

Cable Management Gestión des câblages

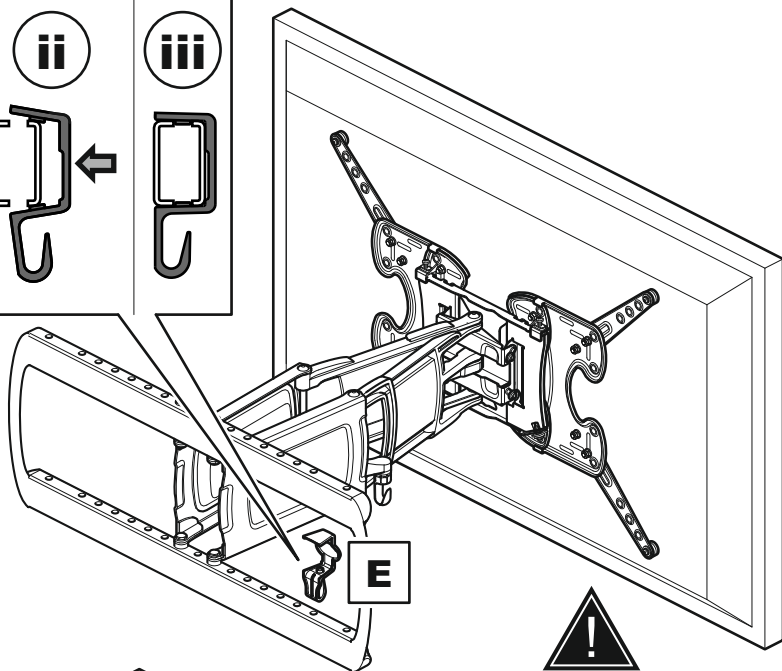
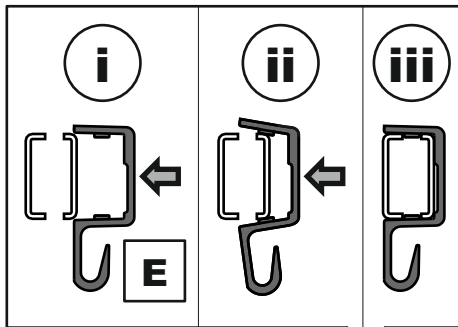

Check all fittings are tight
*Compruebe que todas las
fijaciones estén bien apretadas*

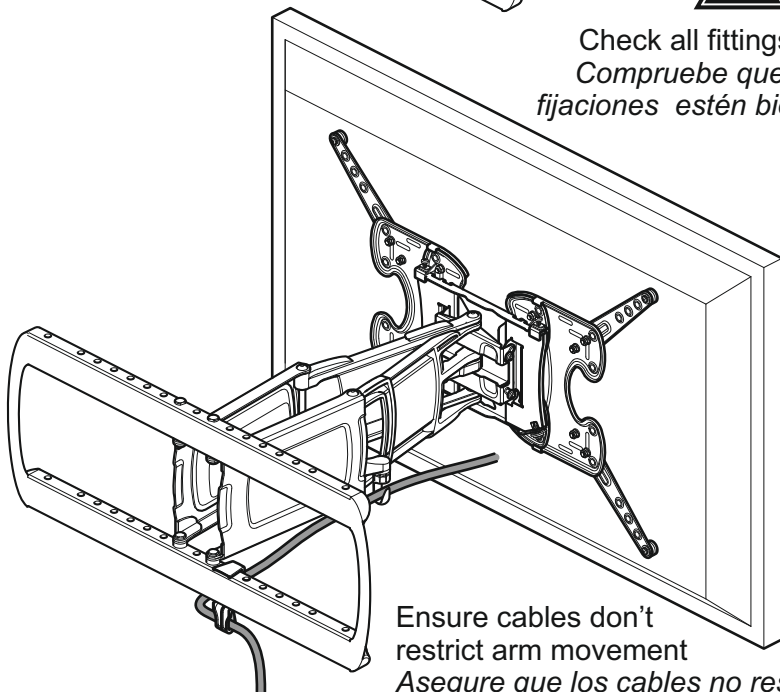

Ensure cables don't
restrict arm movement
*Asegure que los cables no restringen
el movimiento de los brazos*

Optional Lateral Shift
Opcional Desplazamiento lateral



WOOD STUD ONLY
USAR SOLO PERNOS/
ESPÁRRAGOS
PARA MADERA



Remove / Quitar

i

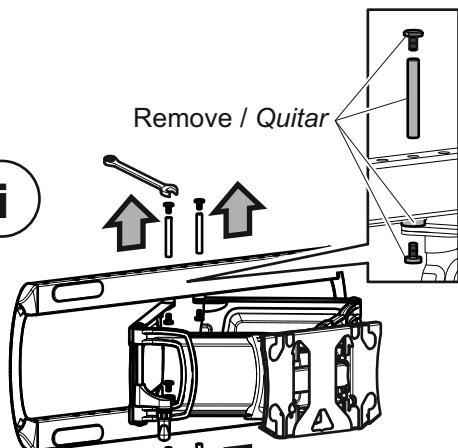

ii

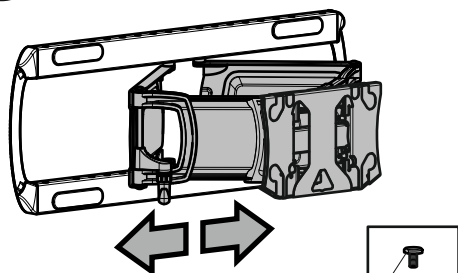

Replace / Reponer

iii

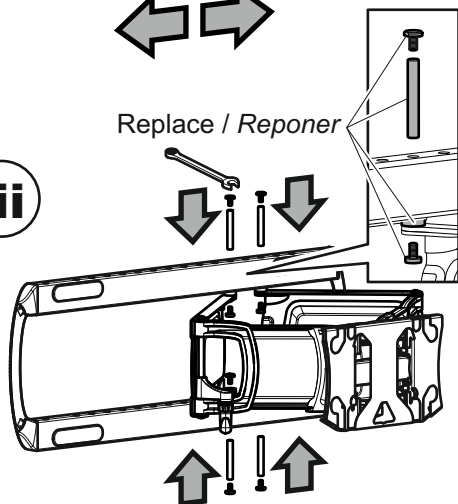

Optional Lock tilt
Opcional Cerradura de la función
de inclinación

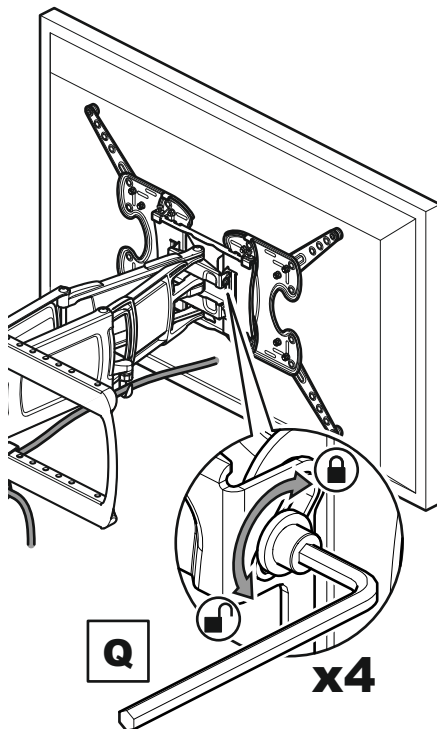

Optional TV Levelling
Opcional Nivelación de TV

