

# CNL454-E

English language / Idioma Español

Leaflet No. / No. de folleto **466043** rev 00

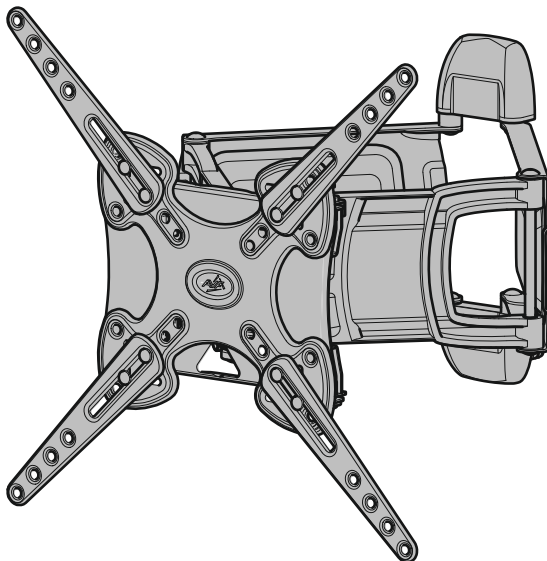

**Read through ALL instructions before commencing installation.**  
**If you have any questions about this product or issues with installation contact the customer services help line before returning this product to the store.**  
**See [www.cmx.avfgroup.com](http://www.cmx.avfgroup.com) for installation video**



**Lea todas las instrucciones antes de comenzar la instalación.**  
**Si tiene alguna pregunta sobre el producto o problemas con la instalación. llame a la línea de servicio al consumidor antes de devolverlo.**  
**Vea [www.cmx.avfgroup.com](http://www.cmx.avfgroup.com) para el video de instalación**



## SOPORTE PARA TV DE PANEL PLANO

**ITM. / ART. 1040700 • Modelo: CNL454-E**

**Para televisores de 56 cm (22 pulg.) a 140 cm (55 pulg.) • Soporta un Peso de hasta 40 kg  
Herramientas recomendadas:**

Detector de Vigas de Madera - Broca para Mampostería 9,5 mm (3/8") - Broca para Madera 3 mm (1/8")

**Tornillos, Reductores y Espaciadores de Televisor:**

M4(J1) 16 mm, M4(J2) 25 mm, M5(J3) 16 mm, M5(J4) 25 mm, M6 (J5) 16 mm, M6(J6) 25 mm, M6(J7) 45 mm,  
M8(J8) 16 mm, M8(J9) 25 mm y M8(J10) 45 mm, puede usar los espaciadores I2 y/o I1 si se requiere.

**Orificios de Televisor:** Ancho mínimo 75 mm máximo 400 mm - Alto mínimo 75 mm máximo 400 mm  
(Teléfono de Servicio al Cliente no válido en México)

**Importado por:** Importadora Primex, S.A. de C.V., Blvd. Magnocentro No. 4 San Fernando La Herradura,  
Huixquilucan, Estado de México, C.P. 52765, RFC: IPR-930907-S70, Tel: (55) 5246-5500, [www.costco.com.mx](http://www.costco.com.mx)

# Assembly Overview Ensambladura General



**2 Person Installation Recommended**  
**Instalación De 2 Personas Recomendado**

**Determine your TV position**  
**Determine la posición de su TV**

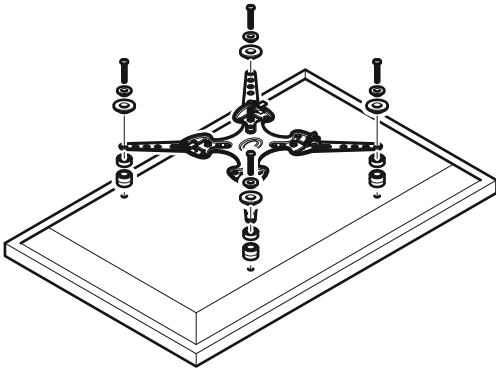
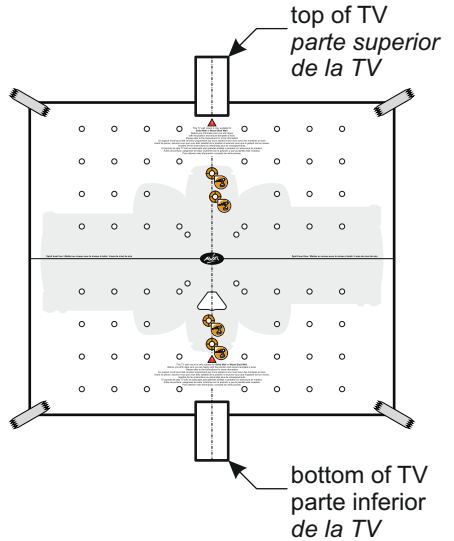

**Fit the TV Mounting Plate**  
**Fije La Placa De Montaje De TV**

**Fit the Wall Bracket**  
**Fije el Soporte de Pared**

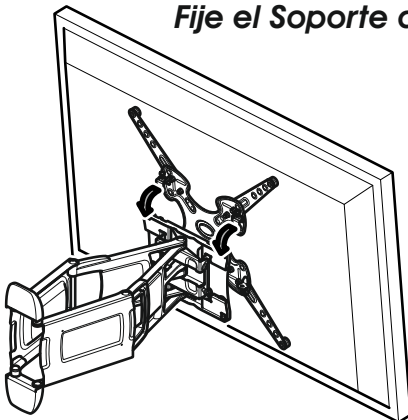
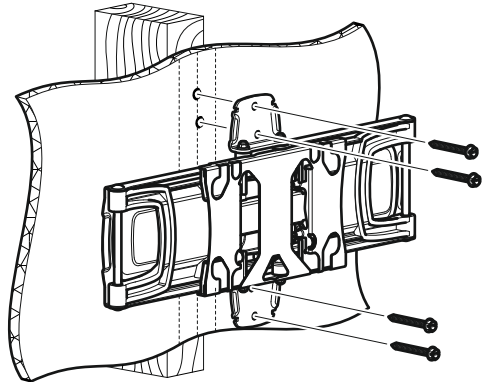

**Connect the TV**  
**Conecte la TV**

## Index Índice

**1** Measure the TV fixing holes Width and Height  
*Mida los orificios de su TV, lo ancho y lo alto*

**2** Preparing the Front Adaptor Plate  
*Preparando La Placa Adaptadora Frontal*

**3** Preparing the TV Mounting Plate  
*Preparando La Placa De Montaje De TV*

**4** Determine your TV position  
*Determine la posición de su TV*

**5** Fitting the TV Mounting Plate  
*Fijando La Placa De Montaje De TV*

**6** Fitting the Wall Bracket  
*Fijando la Placa a la Pared*

**7** Fitting the Wall Bracket Covers  
*Fijando Las Cubiertas Del Soporte De Pared*

**8** Connecting the TV  
*Conectando la TV*

**9** Cable Management  
*Manejo de Cable*

Retain all packaging in case the bracket needs to be returned.

Contents may vary from photography/ Illustrations.

You will not need all these parts, so expect there to be some left over depending upon the specification of your TV.

This product is intended for indoor use only. Use of this product outdoors could lead to failure and personal injury.

It is the responsibility of the installer to ensure that the mounting wall is of a suitable standard and void of any services (eg gas, electricity, water etc).

AVF accept no responsibility for any damage or loss caused by installing this product in a sub standard wall.

*Conserve todos los envasados en caso de que el soporte tenga que ser devuelto.*

*El contenido puede variar de la fotografía / ilustración.*

*No necesitará todas estas partes, espere que sobren algunas según las especificaciones de su TV.*

*Este producto está diseñado para el uso en el interior solamente. El uso de este producto en el exterior podría llevar al fracaso y lesiones personales.*

*Es la responsabilidad del instalador de asegurarse de que la pared de montaje es de un nivel adecuado y carece de todo los servicios (gas, electricidad, agua, etc.).*

*AVF no acepta ninguna responsabilidad por cualquier daño o pérdida causada por la instalación de este producto en una pared inadecuada.*

**Tools Recommended**  
**Herramientas recomendadas**

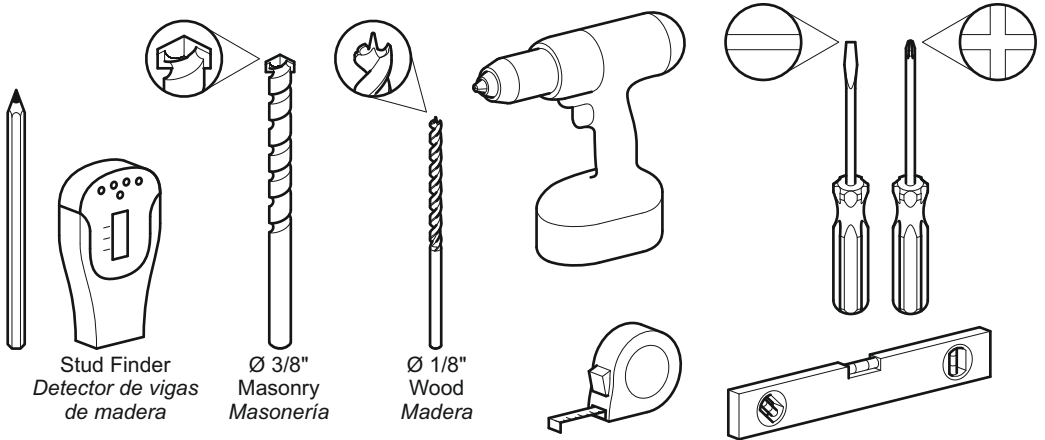

**Boxed Parts**  
**Piezas en la Caja**

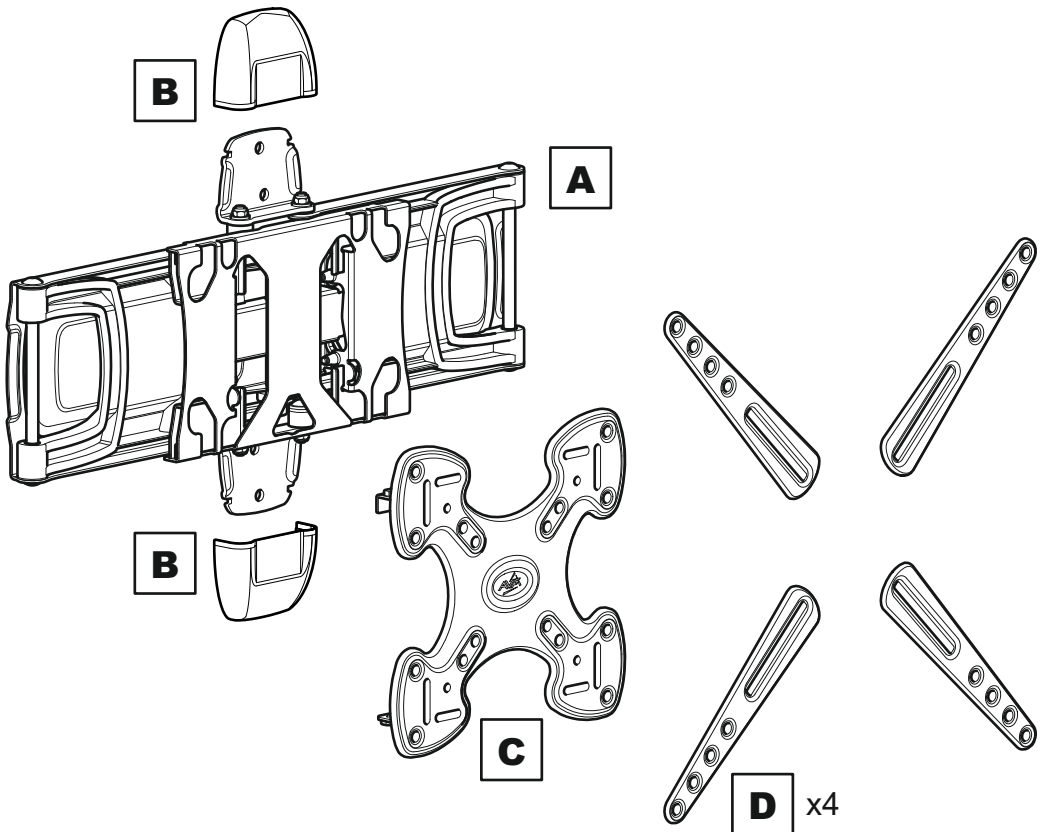

**TV Screws, Reducers and Spacers**  
**Tornillos, Reductores y Espaciadores para TV**

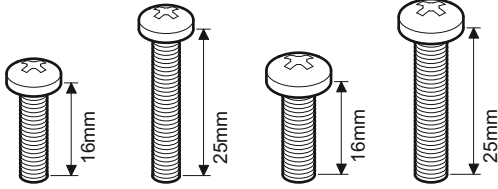

M4 M4 M5 M5  
**J1** x4 **J2** x4 **J3** x8 **J4** x4

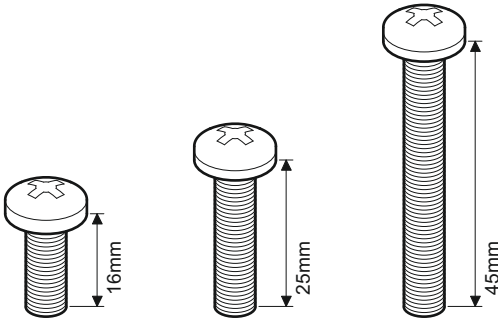

M6 M6 M6  
**J5** x4 **J6** x4 **J7** x4

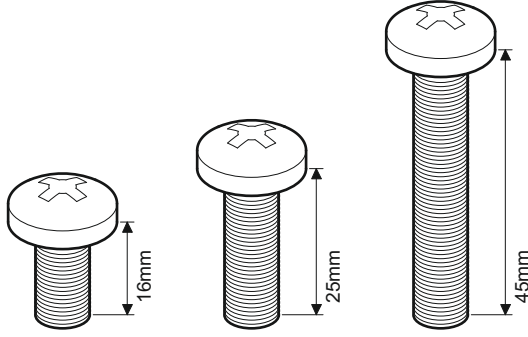

M8 M8 M8  
**J8** x4 **J9** x4 **J10** x4



**H1** x4 **H2** x4 **I1** x12 **I2** x4

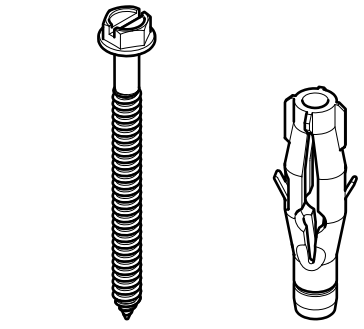
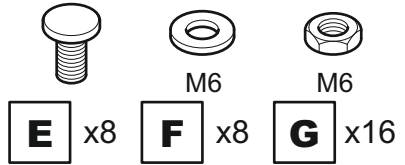

**K** x4 **L** x4

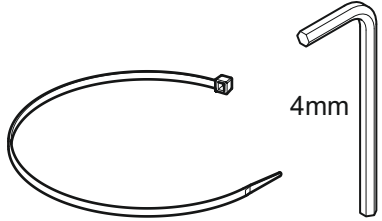

**M** x4 **N** x1

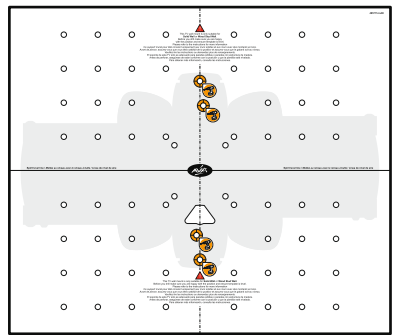

**O1** **O2**

# 1 Measure the TV fixing holes Width and Height Mida los orificios de su TV, lo ancho y lo alto

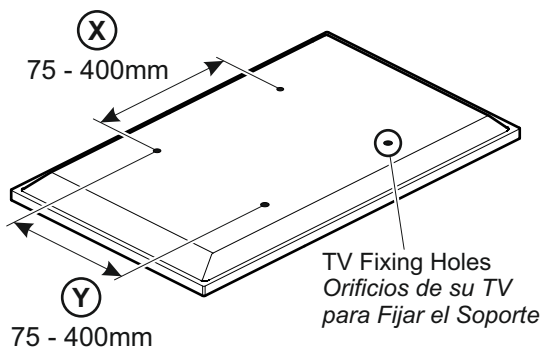

If width (X) is greater than 400mm or height (Y) greater than 400mm STOP installation now and contact the customer help line

Si la anchura (X) es mayor que 400mm o la altura de (Y) es mayor que 400mm DETENGA la instalación inmediatamente y póngase en contacto con la línea de ayuda al cliente

You are provided with 4 diameters of TV fixing screws, **M4**, **M5**, **M6** and **M8**. Determine the screw diameter that fits and remember for step 5.

Se le proporciona con 4 diámetros de tornillos de fijación para su TV: **M4**, **M5**, **M6** y **M8**. Determine el diámetro del tornillo que le quede a su TV y recuérdelo para el paso 5.

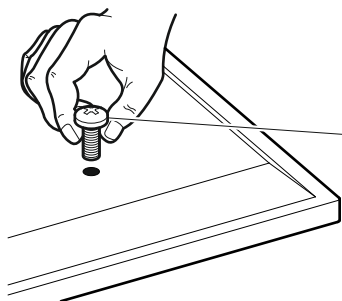

M4 =	J1/J2
M5 =	J3/J4
M6 =	J5-J7
M8 =	J8-J10



After completing step 5 you will have fittings left over, please keep for future reference  
Después de completar el paso 5 usted tendrá conexiones sobrantes, por favor guarde para futura referencia.

# 2 Preparing the Front Adaptor Plate Preparando La Placa Adaptadora Frontal

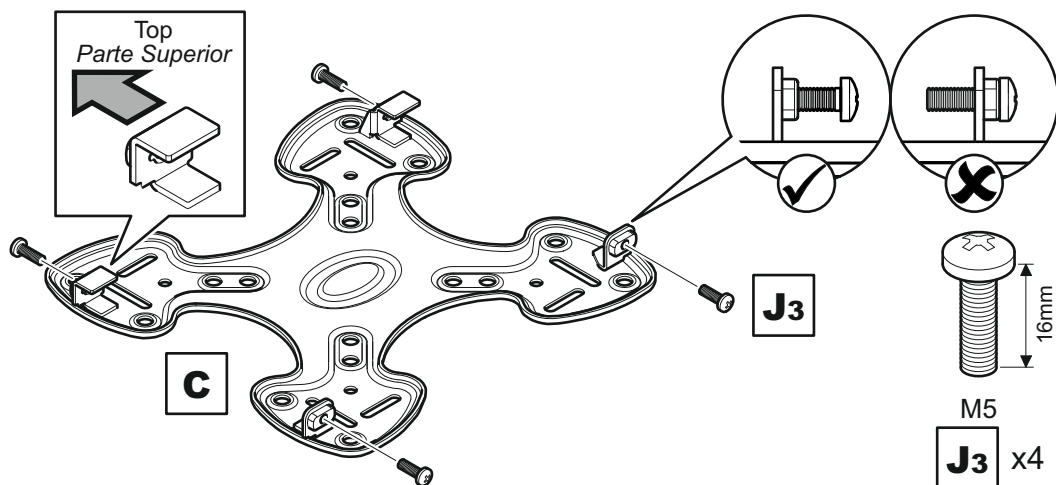

### 3

## Preparing the TV Mounting Plate *Preparando La Placa De Montaje De TV*

Use the option that fits your TV / *Utilice la opción que mejor se adapte a su TV*  
Do not fully tighten / *No ajuste completamente*

#### OPTION 1 / OPCIÓN 1

- |  |                             |
|--|-----------------------------|
| <input checked="" type="radio"/> 75mm  | <input type="radio"/> 75mm  |
| <input checked="" type="radio"/> 100mm | <input type="radio"/> 100mm |
| <input checked="" type="radio"/> 200mm | <input type="radio"/> 100mm |
| <input checked="" type="radio"/> 200mm | <input type="radio"/> 200mm |

#### OPTION 2 / OPCIÓN 2

- |  |                             |   |                                  |
|--|-----------------------------|---|----------------------------------|
| <input checked="" type="radio"/> 300mm | <input type="radio"/> 100mm | <input checked="" type="radio"/> 400mm      | <input type="radio"/> 200mm      |
| <input checked="" type="radio"/> 300mm | <input type="radio"/> 200mm | <input checked="" type="radio"/> 400mm      | <input type="radio"/> 300mm      |
| <input checked="" type="radio"/> 300mm | <input type="radio"/> 300mm | <input checked="" type="radio"/> 400mm      | <input type="radio"/> 400mm      |
| <input checked="" type="radio"/> 400mm | <input type="radio"/> 100mm | <input checked="" type="radio"/> 75 - 400mm | <input type="radio"/> 75 - 400mm |

If in any doubt please call the customer help line.

*Si tiene alguna duda, comuníquese con la línea de atención al cliente.*

#### OPTION 1 / OPCIÓN 1

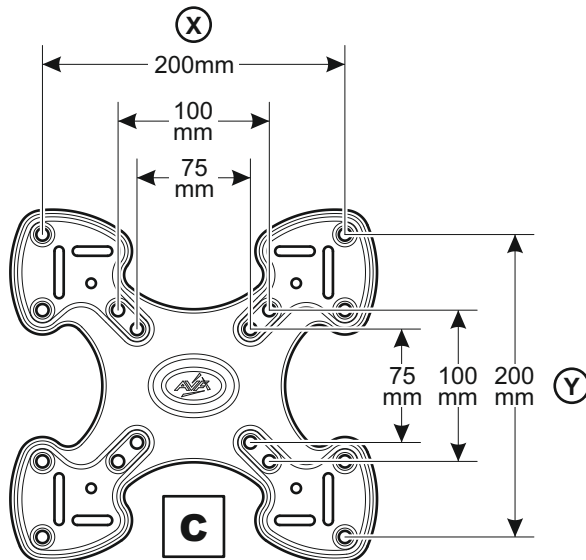

If your TV fixing holes match any of the sizes shown above you will not need to use any adaptors. Please go to step 4.

*Si los orificios de ajuste del TV coinciden con cualquiera de los tamaños que se indican arriba, no necesitará utilizar adaptadores. Continúe con el paso 4*

**OPTION 2 / OPCIÓN 2**



When attaching adaptors **D** you must always use **HOLES x4** and either of the **SLOTS**.

*Para colocar adaptadores **D** deberá siempre utilizar **ORIFICIOS x4** y alguna de las **RANURAS**.*

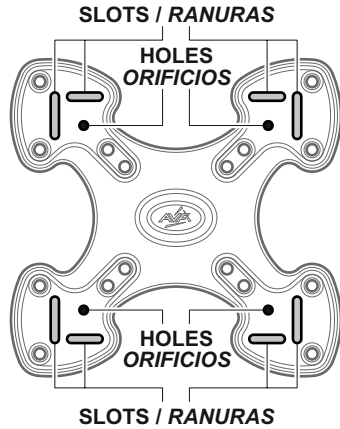

Top  
Parte Superior

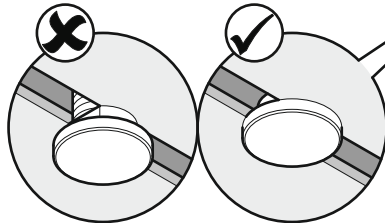
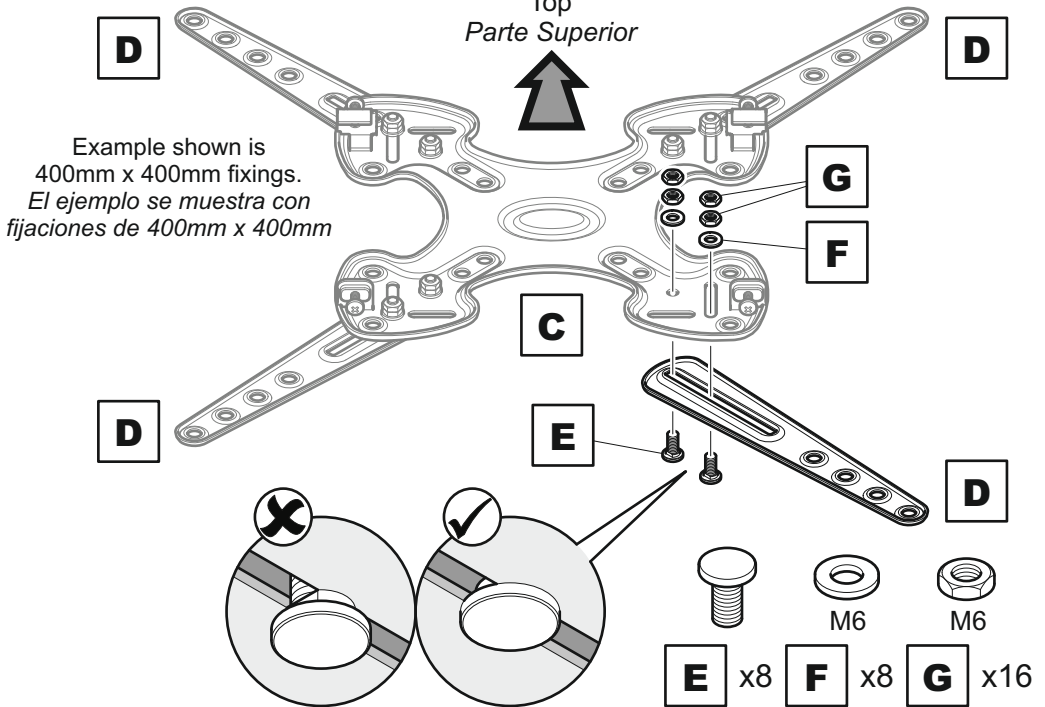

● = HOLES / ORIFICIOS  
○ = SLOTS / RANURAS

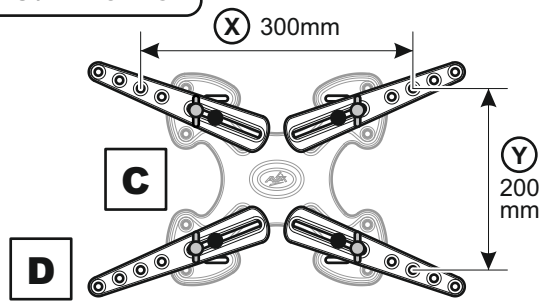
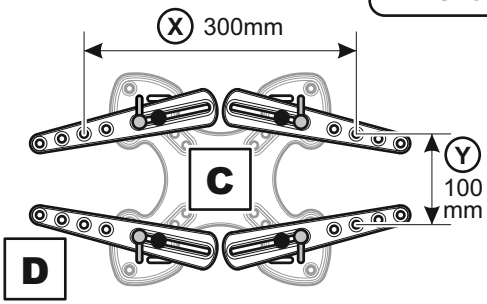



● = HOLES / ORIFICIOS  
○ = SLOTS / RANURAS

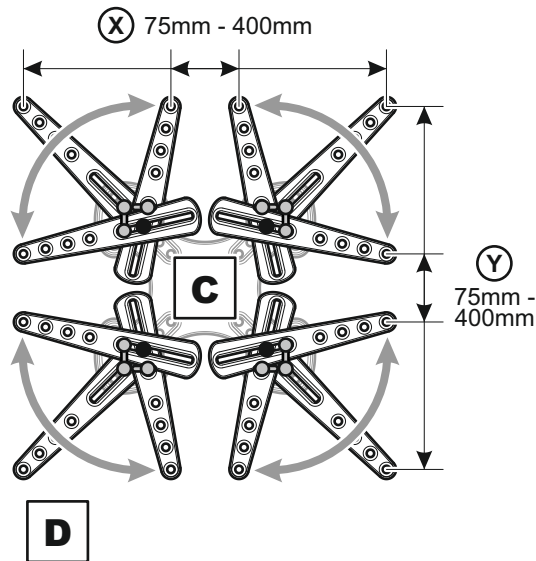
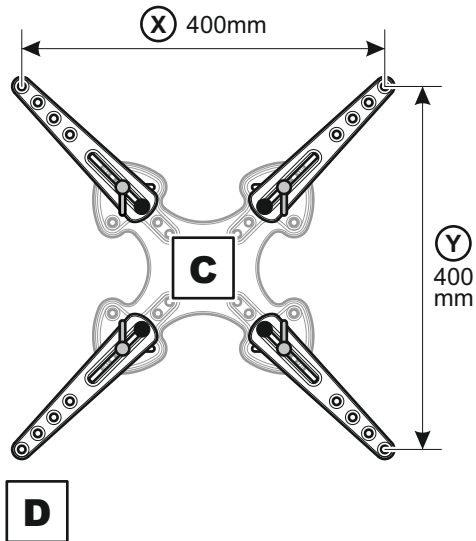
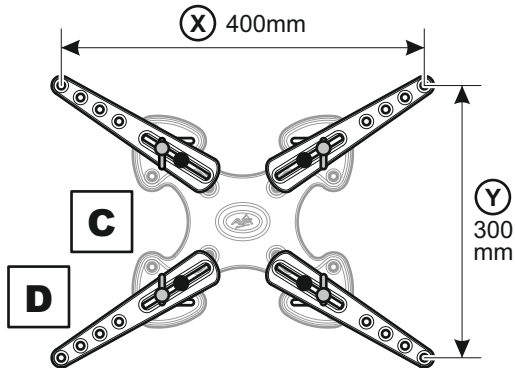
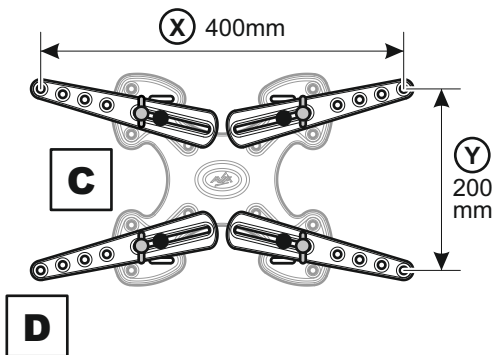
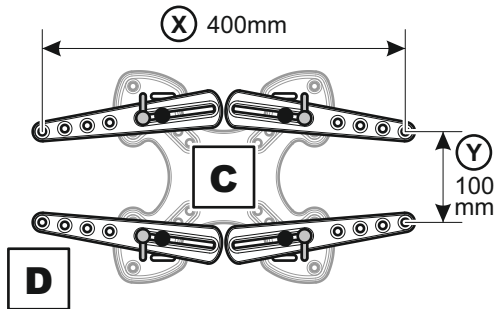
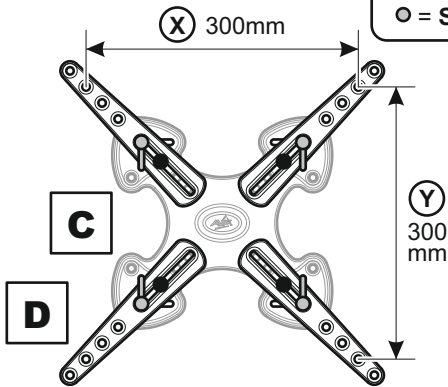

Adaptors **D** can be fixed in different positions in the slots on Plate **C** to match your TV fixing holes.  
*Los adaptadores **D** pueden fijarse en diferentes posiciones en las ranuras de la placa **C** para que coincidan con los orificios de fijación de su televisor.*

# 4

## Determine your TV position *Determine la posición de su TV*

Joining templates O1 and O2 will give you a guide that represents the height and center of YOUR TV so you can position YOUR TV perfectly and know exactly where to drill your wall.  
*Si une las plantillas O1 y O2 obtendrá una idea que representa la altura y el centro de SU TV, por lo cual podrá ubicar SU TV perfectamente y sabrá dónde perforar su pared con precisión*



Assemble Positioning Template  
*Monte la plantilla de posición*

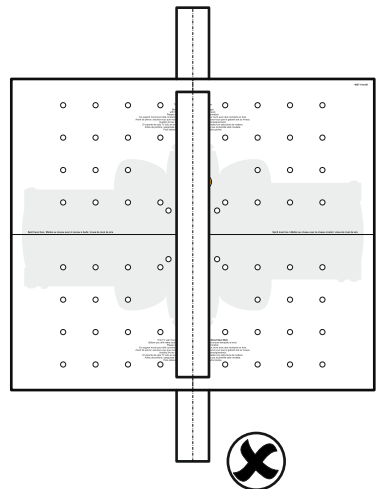
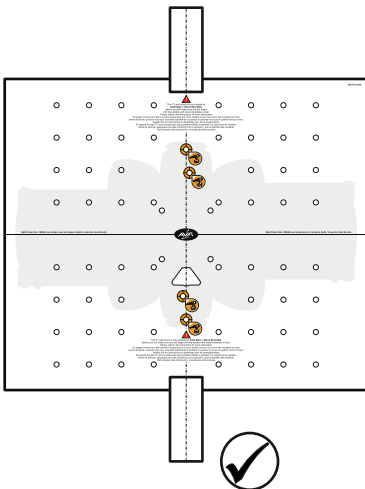
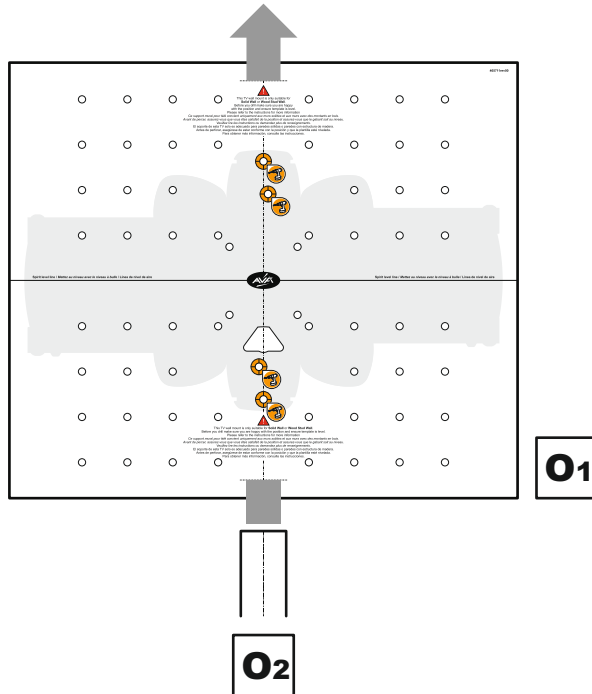



Lay template on the back of the TV as shown in the images below.

Align the fixing holes on the template **O1** with the TV fixing holes on the back of your TV.

If your TV has fixing holes that are not shown on the template **O1** simply punch 4 holes that match your TV fixing holes.

*Coloque la plantilla en la parte posterior de la TV como muestran las imágenes a continuación. Nivele los orificios de anclaje en la plantilla **O1** con los orificios de anclaje de la TV en la parte posterior de la misma. Si su TV tiene orificios de anclaje que no figuran en la plantilla **O1**, simplemente perforo 4 orificios que coincidan con los orificios de anclaje de su TV.*

Example shown is  
400mm x 400mm fixings.  
*El ejemplo se muestra con  
fijaciones de 400mm x 400mm.*

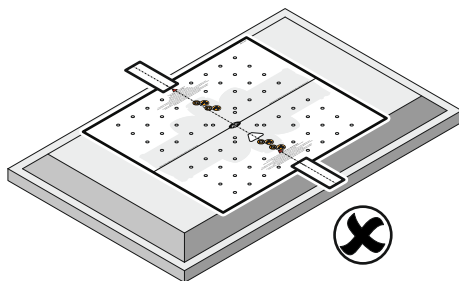
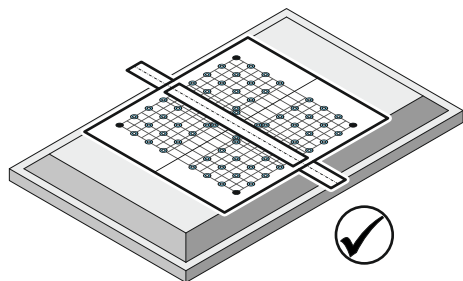
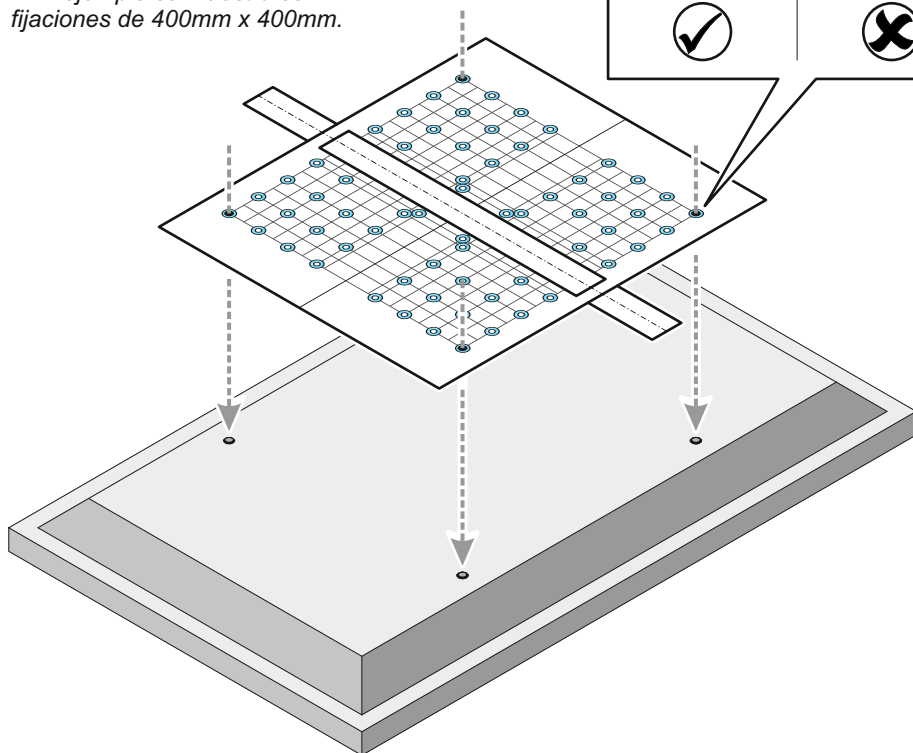
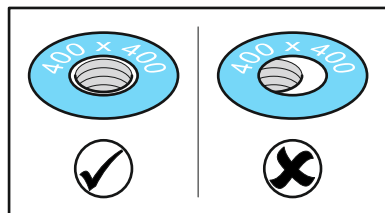



Align template **O2** with the top of your TV and cut so it is flush with the bottom of your TV and stick in position.

*Nivele la plantilla **O2** con la parte superior de su TV y corte para que quede alineada con la parte inferior de su TV y firme en esa posición.*

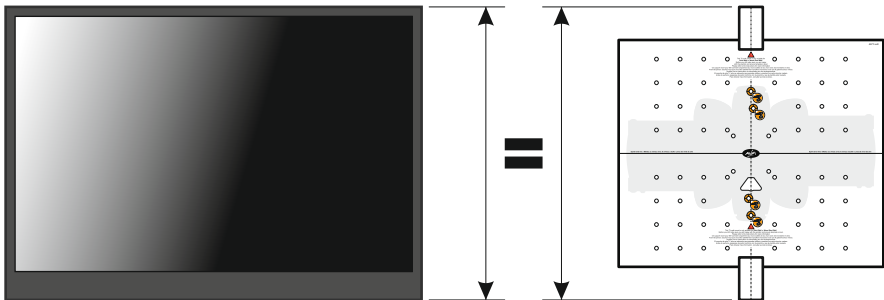
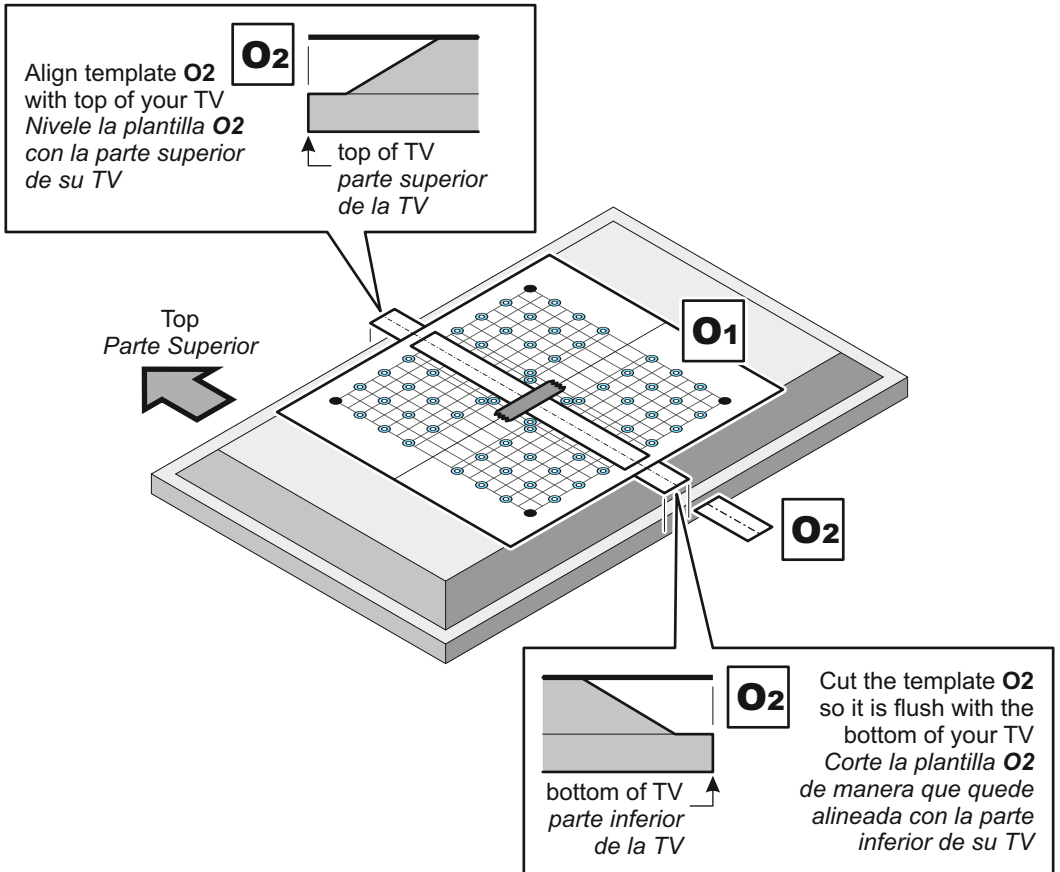

Remove the template from the back of your TV before you continue  
*Quite la plantilla de la parte posterior de su TV antes de continuar*



Use template **O1** and **O2** to determine the position of your TV on the wall.  
When you are happy with the position ensure template is level and fix to wall. Before marking the drill points you will need to determine the wall type that you have i.e. **Solid Wall** or **Wood Stud Wall**. Ensure the drilling area is free from mains services (Gas / Electric / Water).

Use las plantillas **O1** y **O2** para determinar la posición de su TV en la pared.  
Cuando esté conforme con la posición, asegúrese que la plantilla esté nivelada y quede fija a la pared. Antes de marcar los puntos de perforación, deberá determinar el tipo de pared que tiene; por ej.: **pared sólida** o **pared con estructura de madera**. Asegúrese de que el área de perforación no dañará los servicios de red (gas / electricidad / agua)

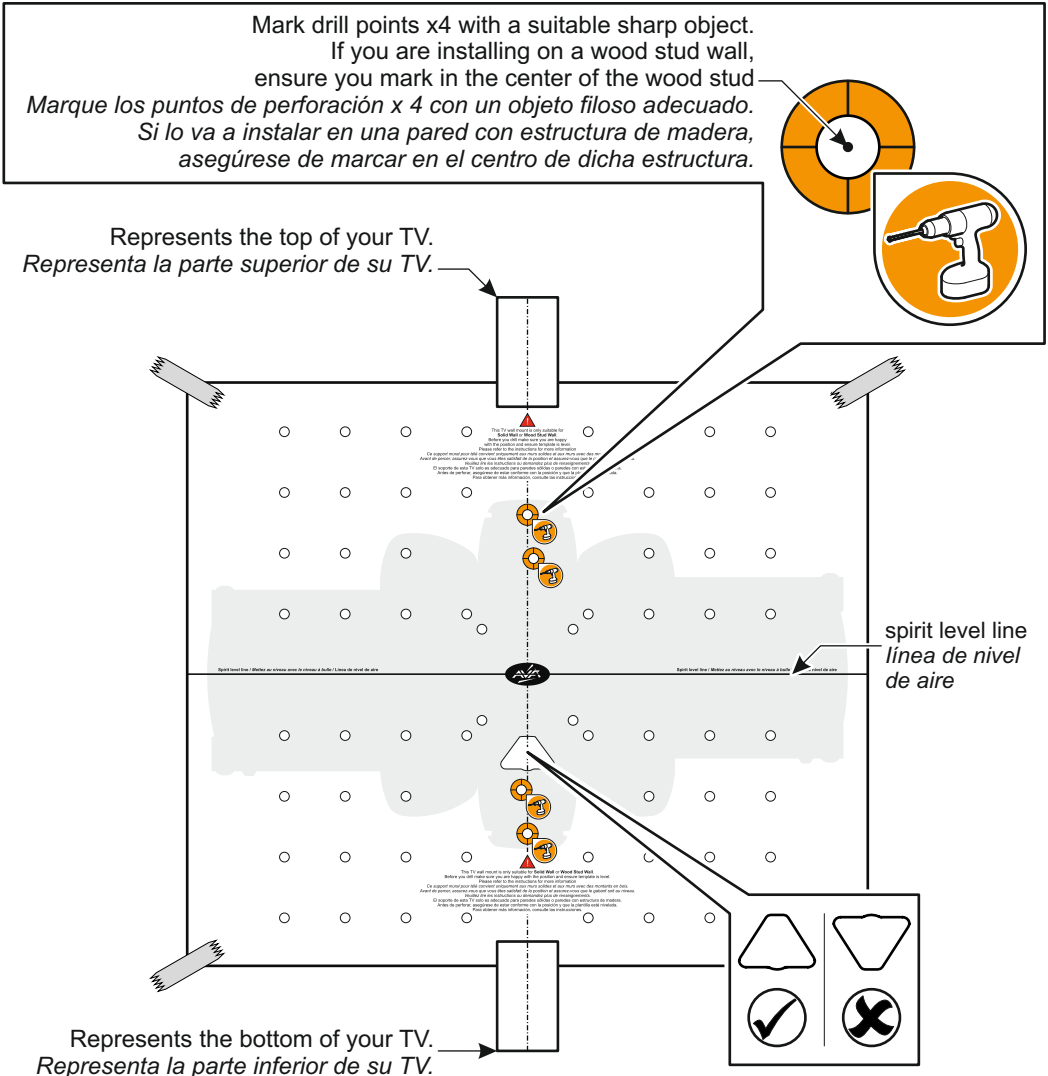

Remove template from wall and continue with installation.  
Quite la plantilla de la pared y proceda con la instalación.

# 5

## Fitting the TV Mounting Plate *Fijando la Placa de Montaje a su TV*

Before you fully tighten the TV mounting plate please check that the mounting plate holes line up with the fixing holes on the back of your TV.

*Antes de fijar completamente la placa de montaje de TV verifique que los orificios de la placa de montaje coincidan con los orificios en la parte posterior de su TV*

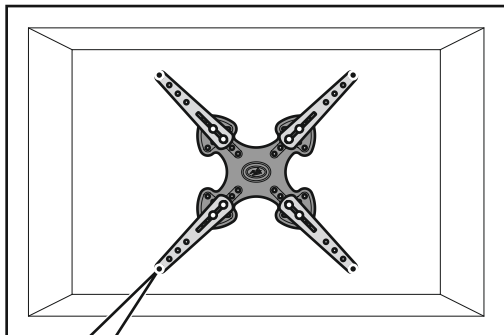

Holes do not line up and small adjustment is required before you fully tighten  
*Los orificios no coinciden y es necesario hacer un pequeño ajuste antes de fijar completamente*

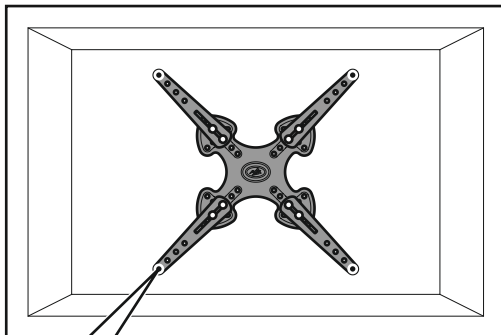

Holes line up and no adjustment is required before you fully tighten  
*Los orificios coinciden y no es necesario hacer ningún ajuste antes de fijar completamente*

### No Spacers *Sin espaciadores*

For TVs with flat/  
unobstructed back  
*Para TVs con la parte posterior plana / sin obstáculos*

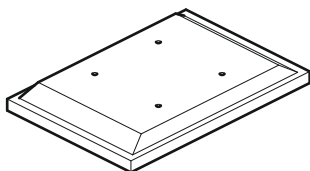

### Spacers *Espaciadores* 1/12

For TVs with irregular/obstructed back  
*Para TVs con la parte posterior irregular / con obstáculos*

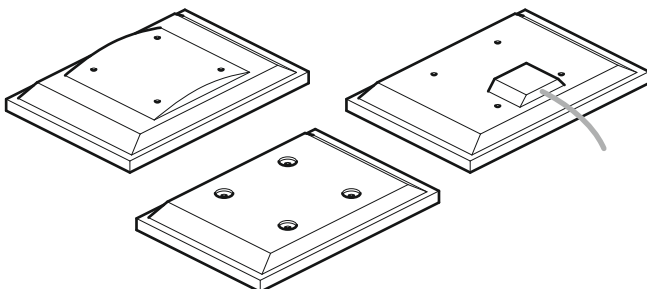

### WARNING / ADVERTENCIA

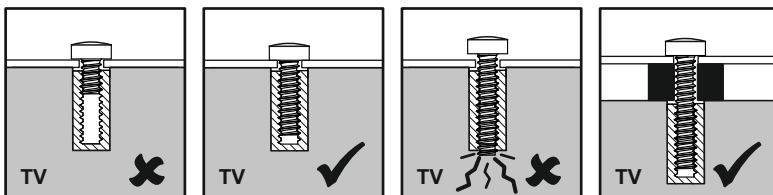

After completing step 5 you will have fittings left over, please keep for future reference.  
*Después de completar el paso 5 usted tendrá conexiones sobrantes, por favor guarde para futura referencia.*

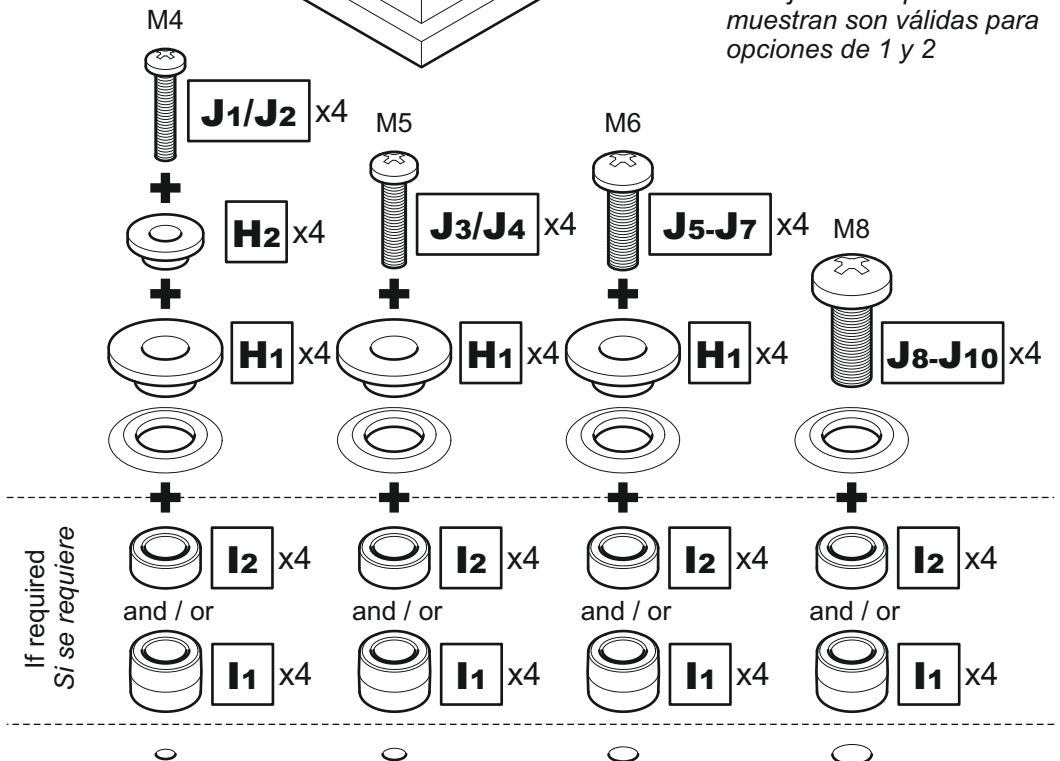
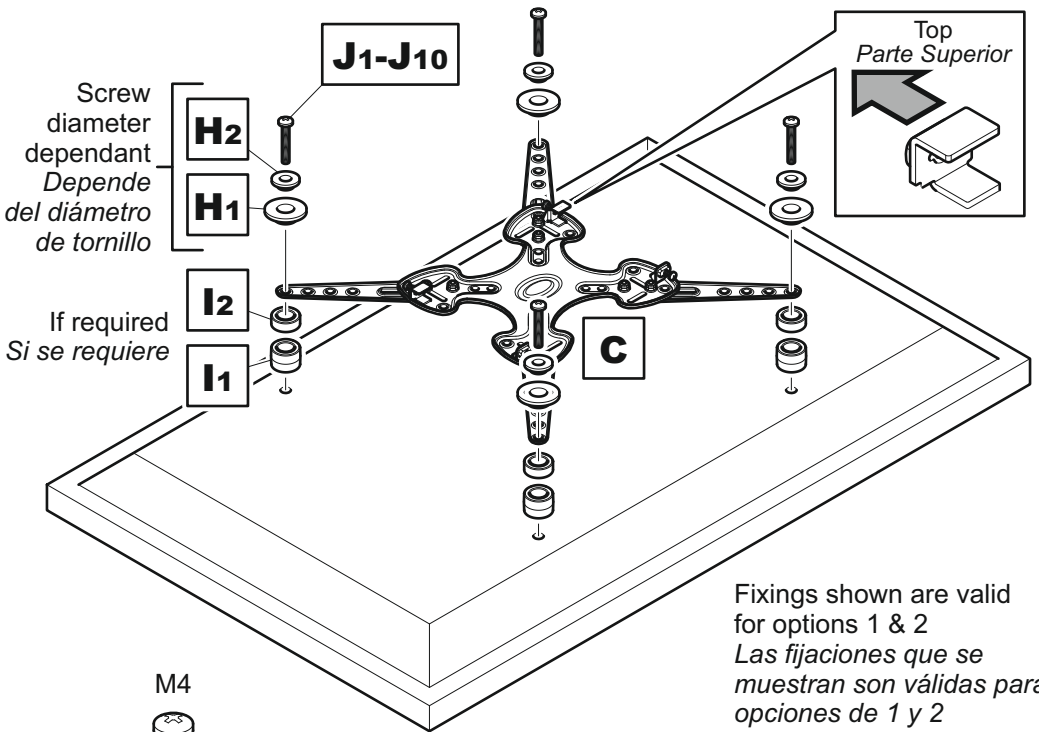

Attach the brackets to the back of your TV using suitable screw, reducer and spacer combinations.  
 Coloque los soportes a la parte posterior de su TV usando la combinación adecuada de tornillo, reductor y espaciador.

## 6 Fitting the Wall Bracket Fijando la Placa a la Pared

### Solid Wall / Pared sólida

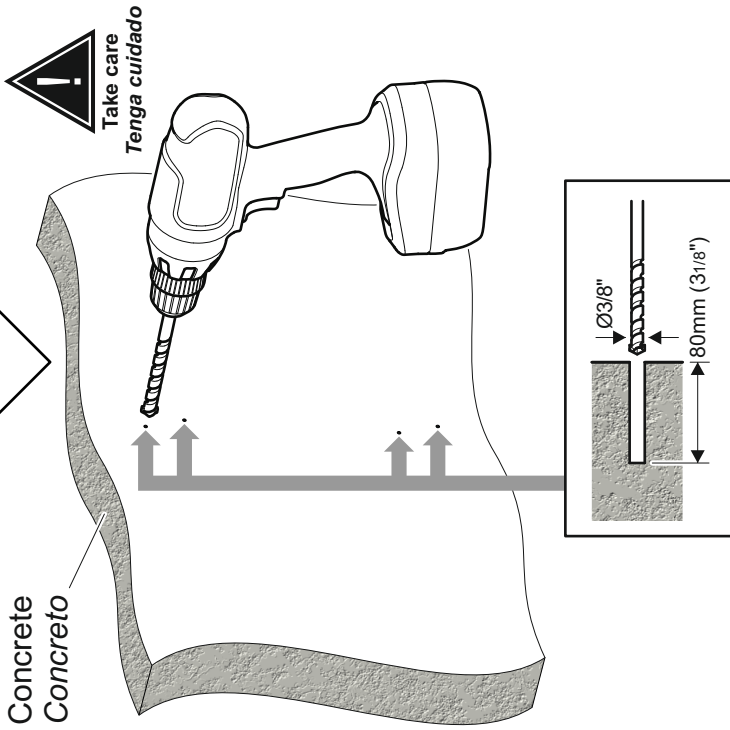

 Remove dust from hole  
Elimine el polvo del agujero

### Wood Stud / Viga de madera

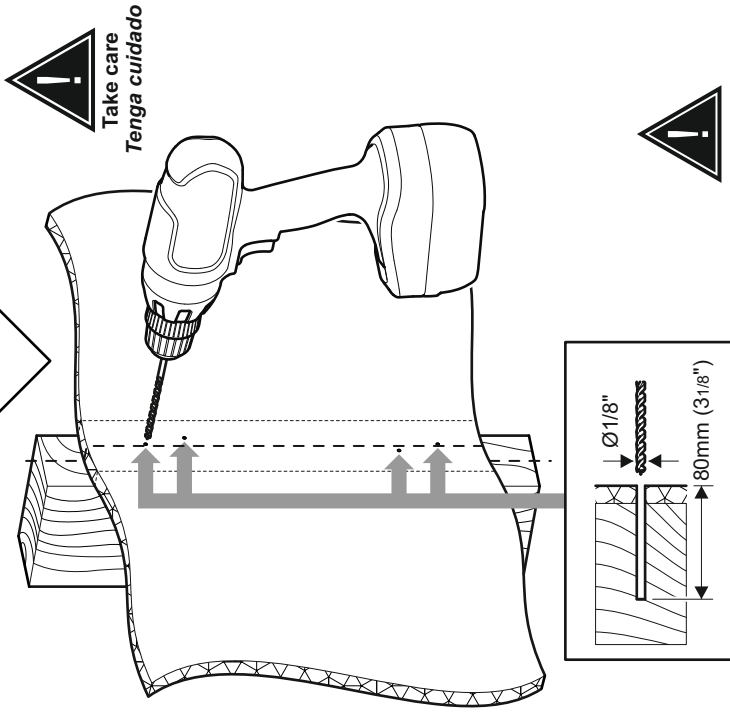

Ensure bracket is in the  
centre of the wood stud  
Asegúrese de que el  
soporte está en el centro  
de la viga de madera



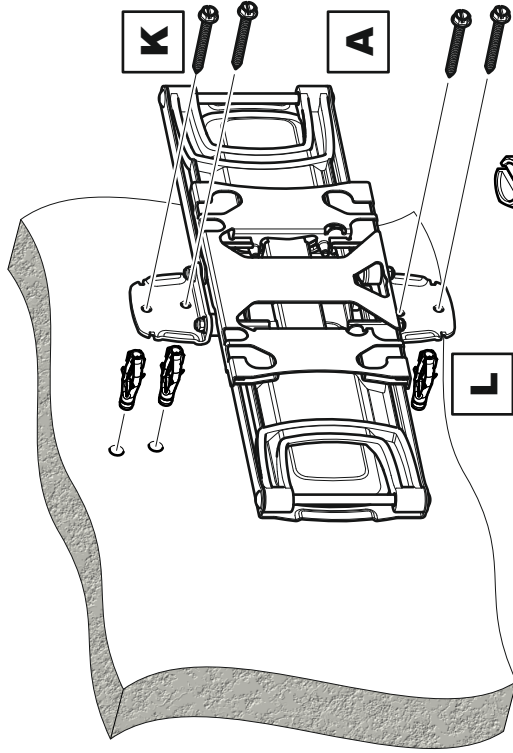
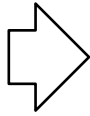

**K**

**A**

**L**

 Lubricate screw  
thread with soap  
*Lubrique la rosca  
del tornillo con jabón*

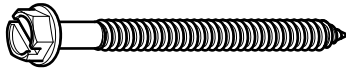

**K** x4

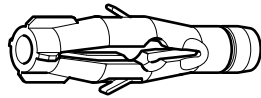

**L** x4



**DO NOT** over tighten screws  
Tighten screws by hand only  
**NO** sobre apriete los tornillos.  
*Apriete los tornillos sólo a mano*

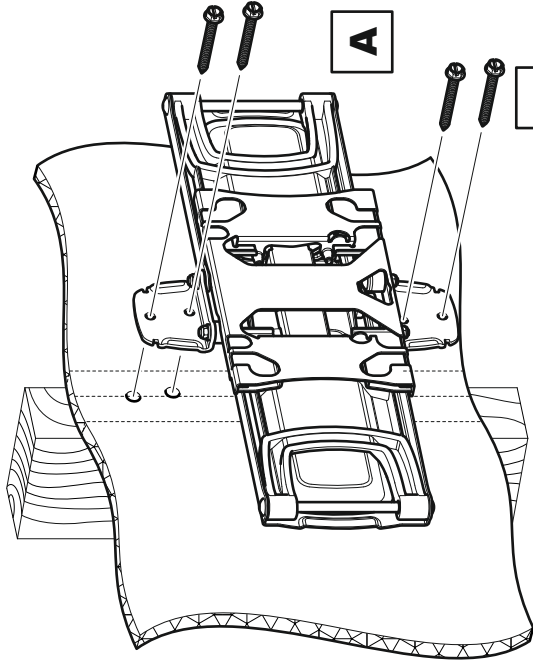
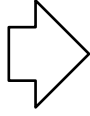

**A**

**K**

 Lubricate screw  
thread with soap  
*Lubrique la rosca  
del tornillo con jabón*



**K** x4



**DO NOT** over tighten screws  
Tighten screws by hand only  
**NO** sobre apriete los tornillos.  
*Apriete los tornillos sólo a mano*

**7**

## Fitting the Wall Bracket Covers *Fijando Las Cubiertas Del Soporte De Pared*

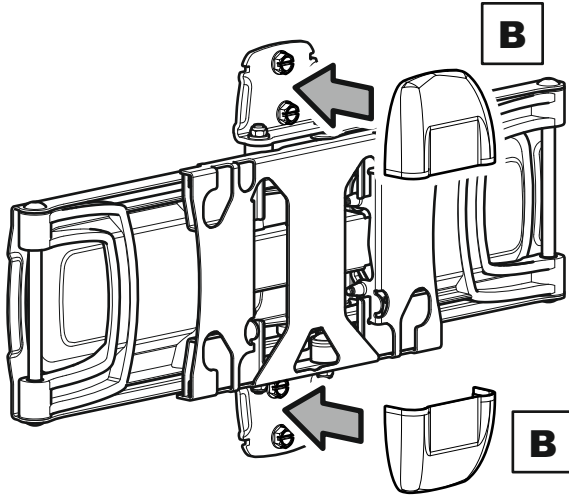
**8**

## Connecting the TV *Conectando la TV*

Attaching and Locking  
*Sujetando y Asegurando*

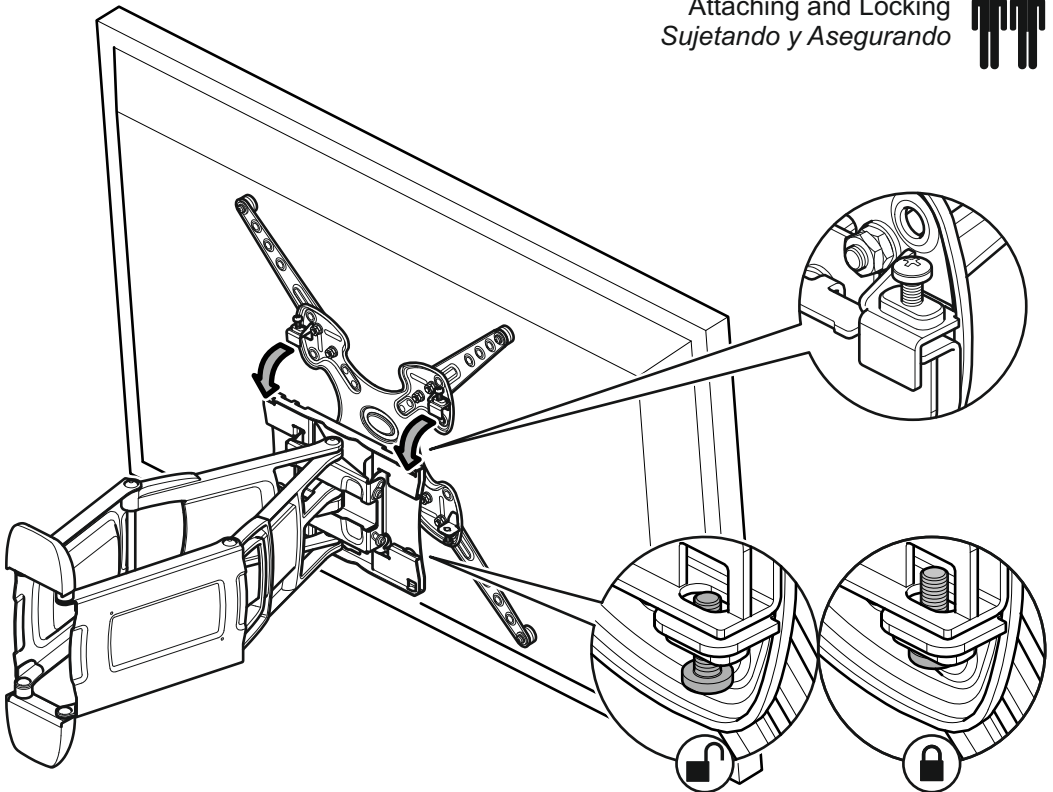

# 9

## Cable Management Manejo de Cable

Ensure cables don't restrict arm movement  
*Asegure que los cables no restringen el movimiento de los brazos*

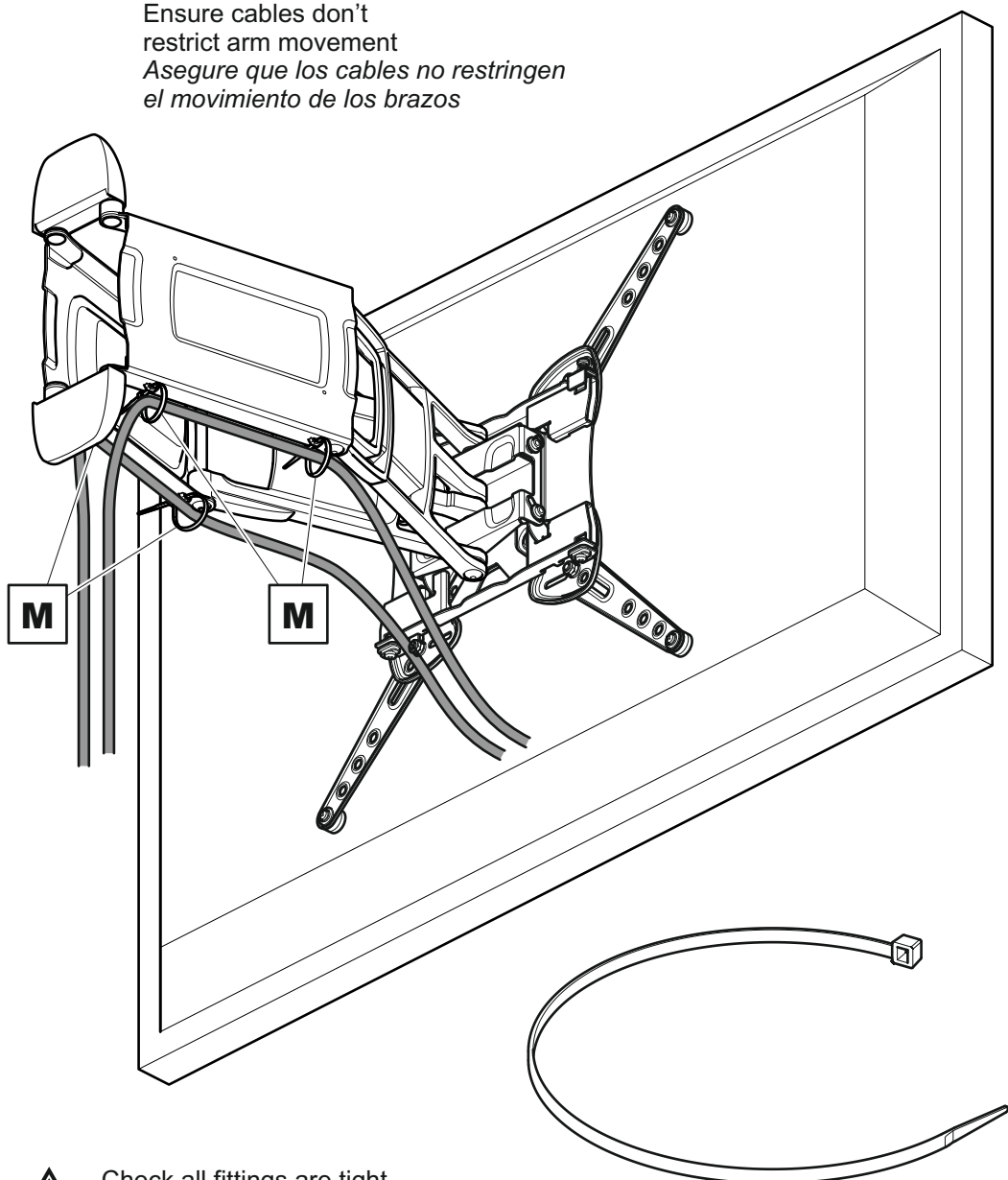

Check all fittings are tight  
*Compruebe que todas las fijaciones estén bien apretadas*

**M** x4

**Optional**  
**Opcional**

Lock tilt / Cerradura de la función de inclinación

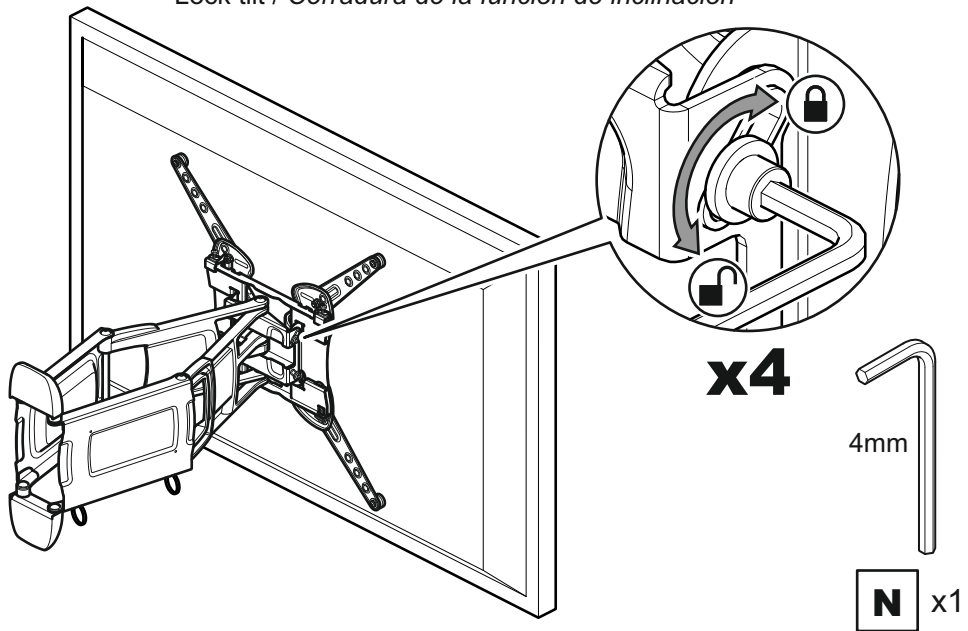

TV Levelling / Nivelación de TV

