

465803 rev 02

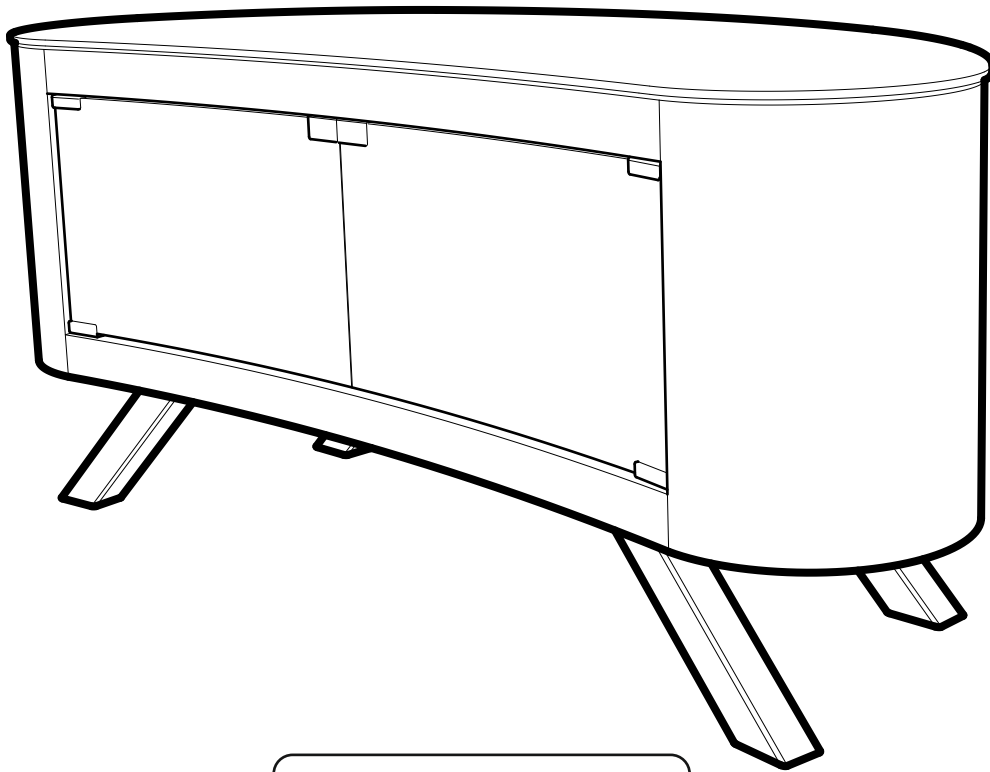

[www.avfgroup.com](http://www.avfgroup.com)



Read through **ALL** instructions before commencing assembly.  
If you have any questions about this product or issues with assembly contact the customer services help line before returning this product to the store.



Lisez toutes les instructions avant de débiter l'installation.  
Si vous avez des questions sur ce produit ou sur son installation, contactez le service d'assistance clientèle avant de renvoyer le produit au magasin.



Lea todas las instrucciones antes de empezar la instalación.  
Si usted tiene alguna pregunta acerca de este producto o problemas con la instalación contacte los servicios de ayuda al cliente antes de devolver este producto a la tienda.

CUSTOMER SERVICES HELP LINE NUMBER:  
NUMÉRO DE L'ASSISTANCE CLIENT:  
NUMERO DE SERVICIO DE ATENCION AL CLIENTE:  
**+44 (0) 333 320 0463 (UK)**

CUSTOMER SERVICES HELP LINE NUMBER:  
NUMÉRO DE L'ASSISTANCE CLIENT:  
NUMERO DE SERVICIO DE ATENCION AL CLIENTE:  
**1-800 667 0808 (USA)**

**AVF Group Ltd.** Hortonwood 30, Telford, Shropshire, TF1 7YE, England  
**AVF Group, Inc.** 2775 Broadway, Cheektowaga, Buffalo, New York, 14227, USA

### IMPORTANT INFORMATION!

We advise that before starting the assembly of this product that you familiarise yourself with the instructions and the parts list in this leaflet.

### INFORMATIONS IMPORTANTES!

Nous vous recommandons de vous familiariser avec ces instructions et la liste des pièces détachées contenues dans ce document avant de commencer l'assemblage de ce produit.

### INFORMACIÓN IMPORTANTE!

Le recommandamos que antes de comenzar el ensamblaje de este producto se familiarize con las instrucciones y la lista de partes en esta hoja informativa.

#### Do not's

Do not over tighten any part of this assembly.

Do not place hot or cold objects on to or close next to any glass surface unless the object is sufficiently insulated to prevent contact.

Do not strike the glass with hard or pointed items.

Do not sit or stand upon horizontal glass surfaces.

Do not use washing powders or other substances containing abrasives when cleaning the glass.

#### À ne pas faire

Ne serrez pas trop fort aucun des éléments de cet assemblage.

Ne placez aucun objet froid ou chaud sur ou à proximité de toute surface en verre à moins que celui-ci ne présente une isolation suffisante pour empêcher tout contact.

Ne frappez pas les surfaces en verre avec des objets lourds ou pointus.

Ne vous asseyez ni ne montez pas sur les surfaces horizontales en verre.

N'utilisez pas de poudre à récurer ou toute autre substance abrasive lorsque vous nettoierez les surfaces en verre car cela risquerait de provoquer des rayures.

#### No haga

No apriete demasiado ninguna de las piezas de este soporte.

No coloque objetos calientes o fríos en o cerca de cualquier superficie de vidrio, a menos que el objeto esté aislado para prevenir contacto directo.

No golpee el vidrio con artículos fuertes o punzantes.

No se siente o se pare en superficies de vidrio.

No use detergentes para lavar u otras sustancias que contengan abrasivos cuando esté limpiando el vidrio ya que estas pueden rayarlo.

#### Do's

Do use a damp cloth with diluted washing up liquid for cleaning the glass surfaces.

Do use a soft cloth with a suitable furniture polish when cleaning wooden panels.

#### À faire

Utilisez un chiffon humide imprégné de liquide vaisselle dilué pour le nettoyage des surfaces en verre.

Utilisez un chiffon doux avec un produit adapté pour le nettoyage des meubles afin de nettoyer les panneaux en bois.

#### Si haga

Use un trapo suave con líquido diluido en agua para limpiar las superficies de vidrio.

Use un trapo suave con limpiador o embellecedor de muebles cuando limpie paneles de madera.

#### Maximum TV weight and shelf capacities

Poids maximal du téléviseur et capacité de charge de l'étagère

Máximo peso y capacidad del estante de TV

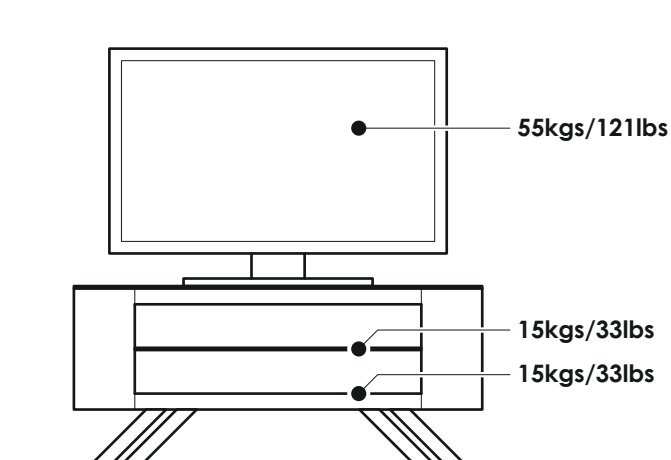

With optional FL602KIT  
Avec FL602KIT optionnel  
Con FL602KIT opcional

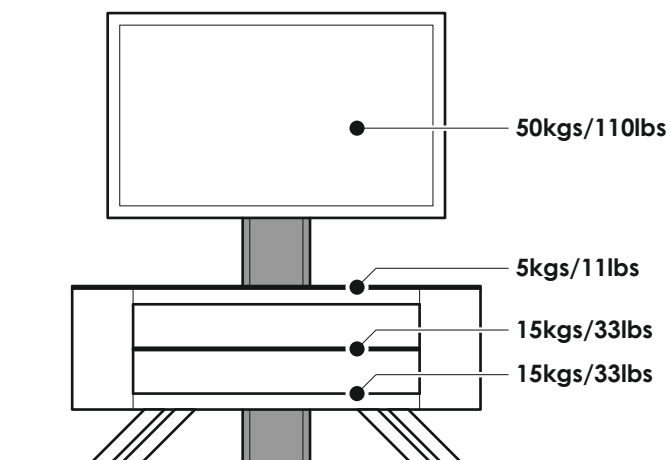

**WARNING:** Wherever possible distribute weight evenly.

**AVERTISSEMENT:** Répartissez le poids de manière uniforme lorsque cela est possible.

**ADVERTENCIA:** En la medida de lo posible distribuya el peso uniformemente.

**IMPORTANT:** Check all nuts and bolts from time to time.

**IMPORTANTES:** Vérifiez tous les écrous et les boulons de temps à autre.

**IMPORTANTE:** Compruebe todos los tornillos y tuercas de vez en cuando.

**Boxed Parts**  
*Pièces empaquetées*  
 Piezas en la Caja

**Tools Recommended**  
*Outils recommandés*  
 Herramientas recomendadas

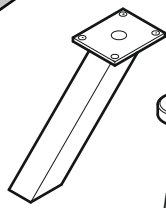
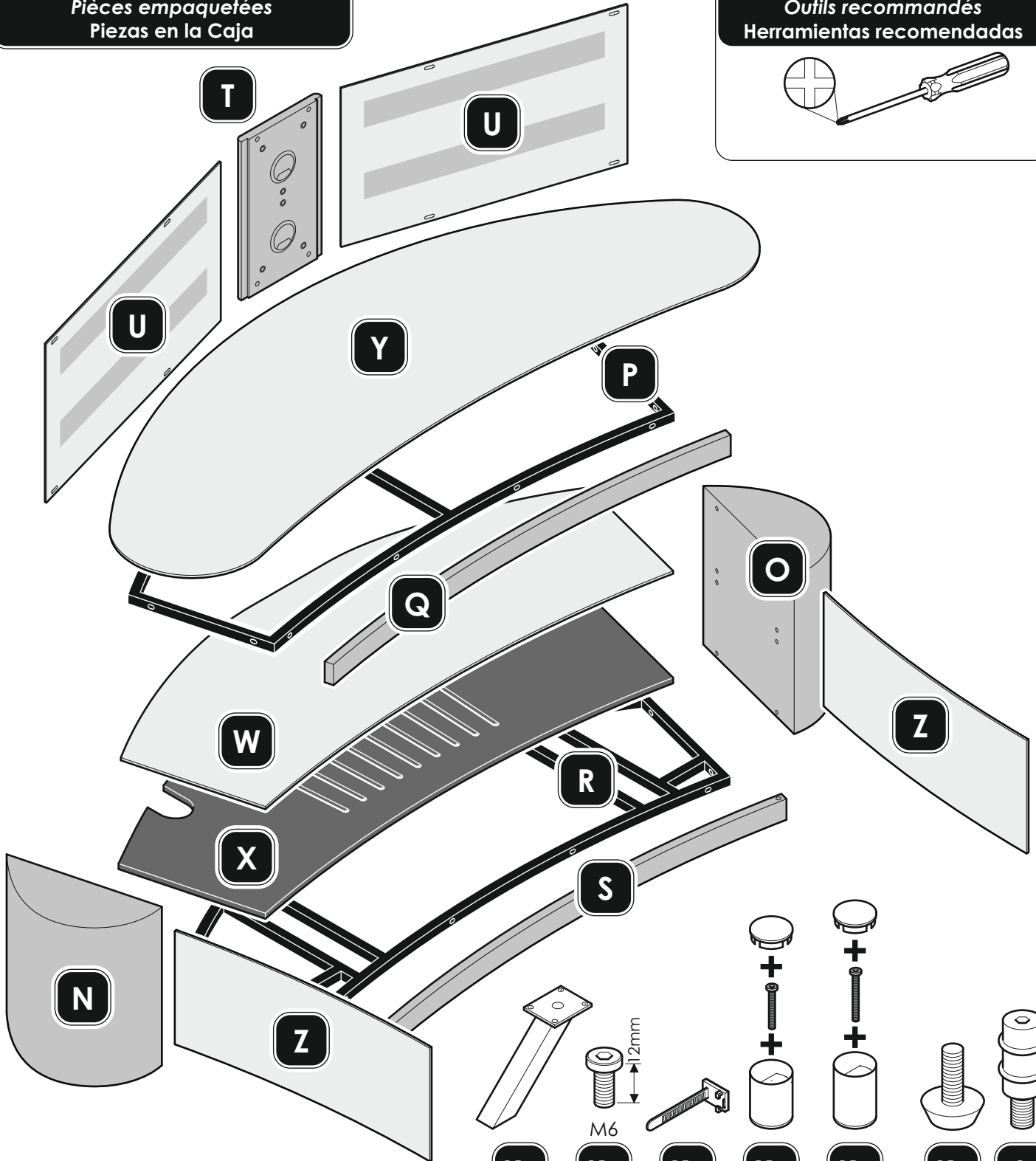
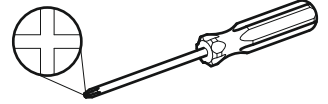

**K1**  
x4

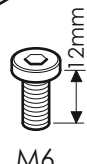

**K2**  
x16

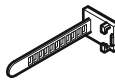

**K3**  
x4

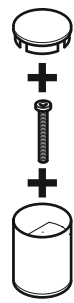

**K4**  
x2

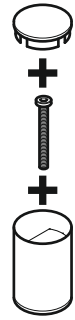

**K5**  
x2

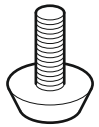

**K6**  
x6



**L**  
x5



**A**  
x4

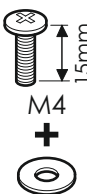

**B**  
x8

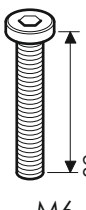

**C**  
x20



**D**  
x12

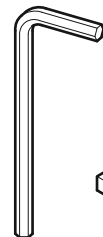

**E**  
x1

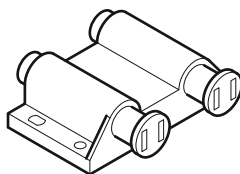

**F**  
x1

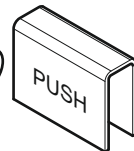

**G**  
x2

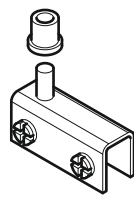

**H**  
x2

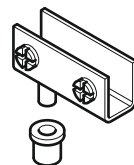

**I**  
x2



**J**  
x4

You are provided with 3 different styles of feet  
3 styles de pieds différents sont inclus  
Está provisto de 3 estilos diferentes de patas

**WARNING:** Wherever possible distribute weight evenly.  
**AVERTISSEMENT:** Répartissez le poids de manière uniforme lorsque cela est possible.  
**ADVERTENCIA:** En la medida de lo posible distribuya el peso uniformemente.

OPTION 1  
OPTION 1  
OPCIÓN 1

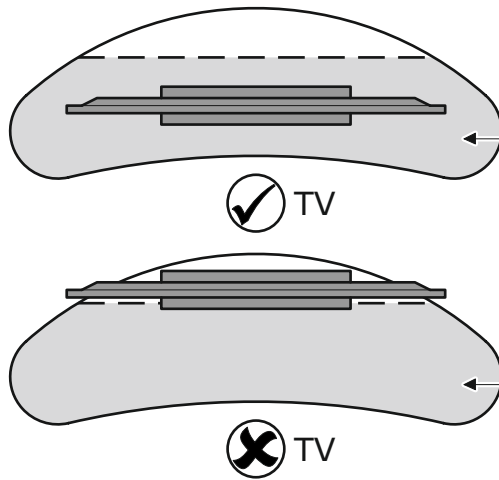

TV must sit within grey area  
*Le téléviseur doit s'asseoir à l'intérieur de la zone grise*  
El aparato de TV debe colocarse en el área gris

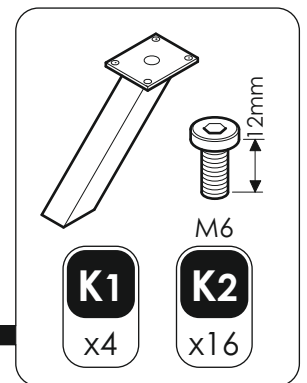
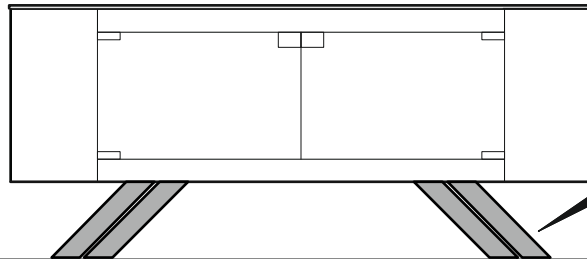

OPTION 2  
OPTION 2  
OPCIÓN 2

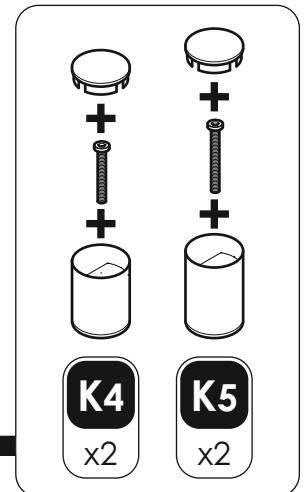
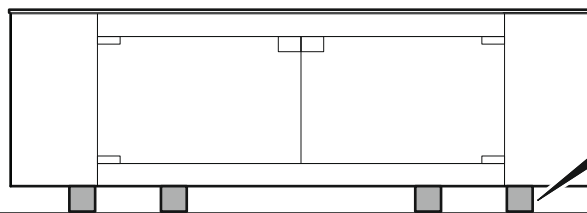

OPTION 3  
OPTION 3  
OPCIÓN 3

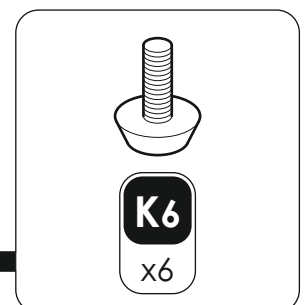
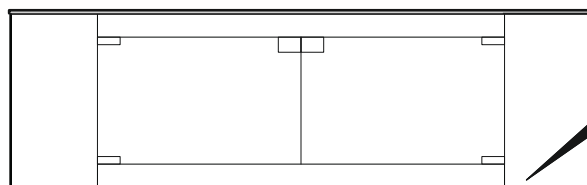

1

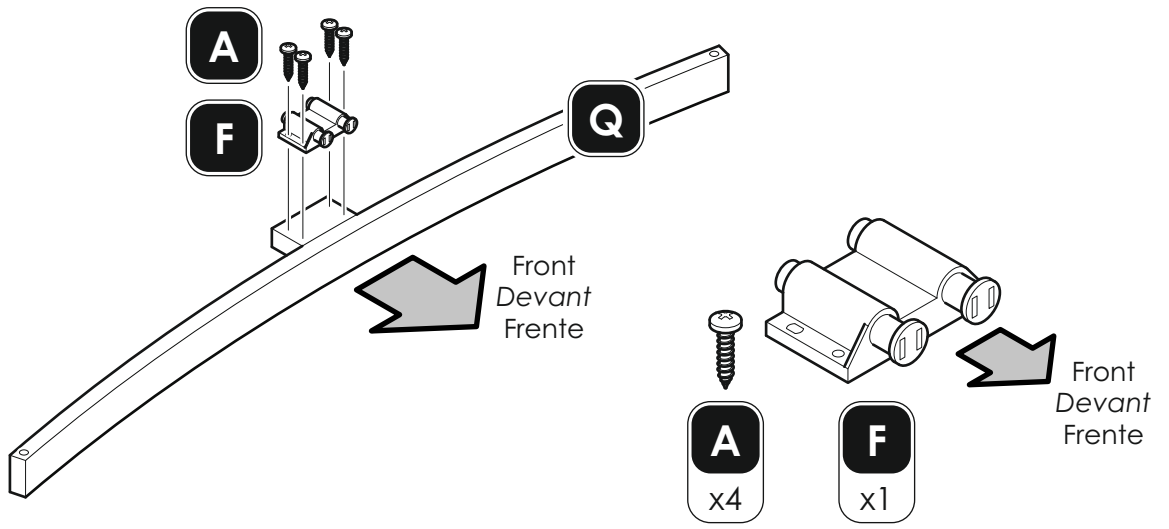

2

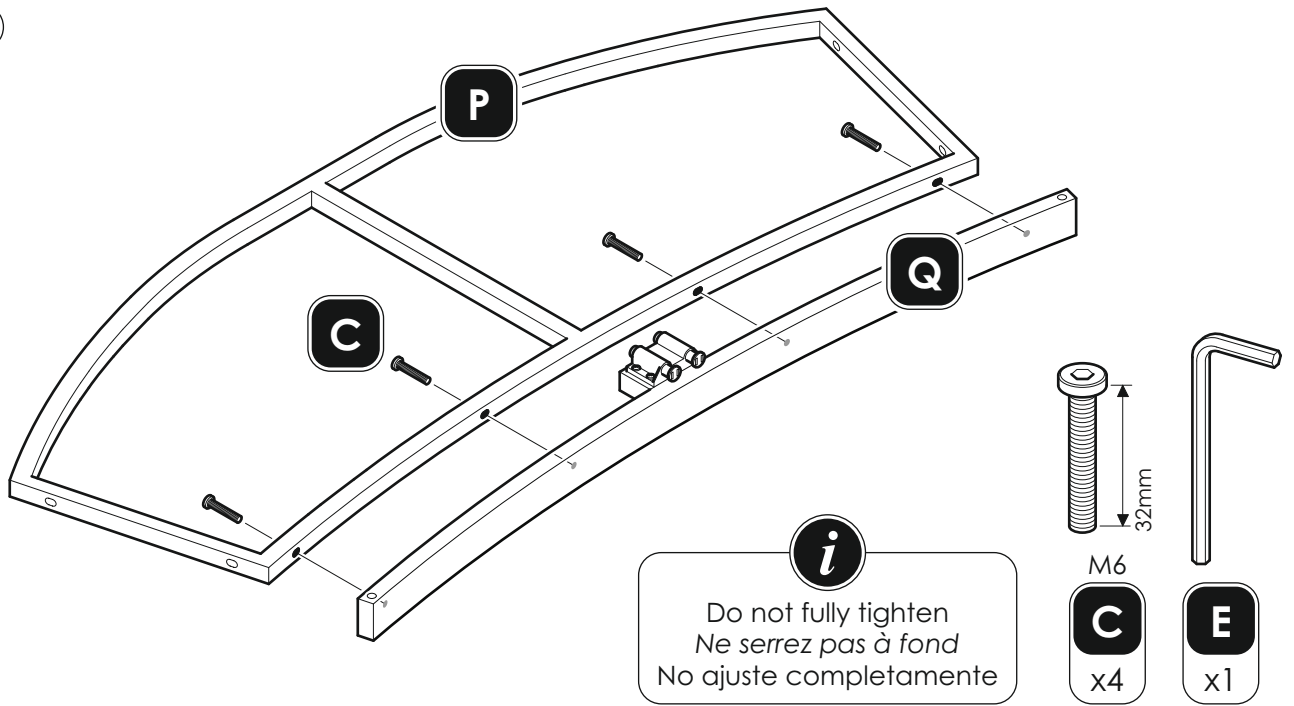

3

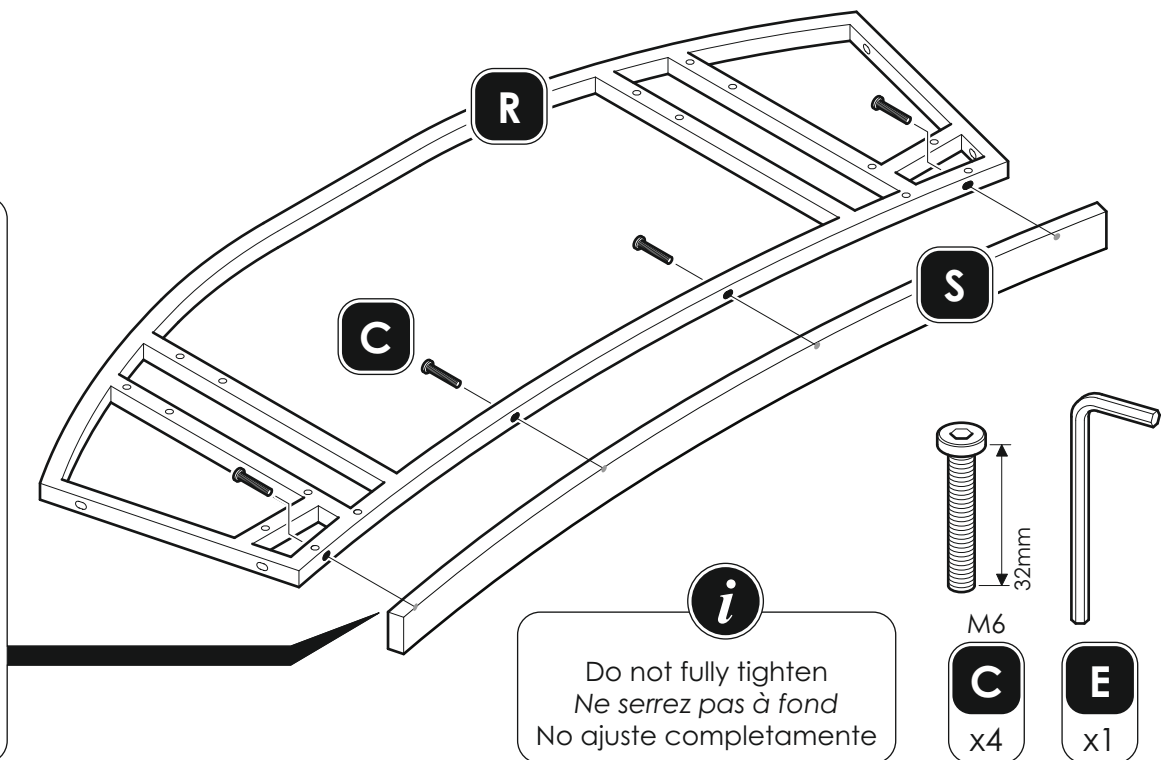
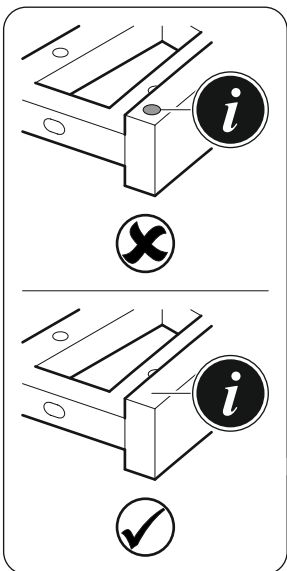

4

Use the appropriate option below to attach your choice of feet  
*Employez l'option appropriée, plus bas, pour fixer le pied que vous aurez choisi*  
Para conectar las patas de su elección, utilice la opción correspondiente que se ofrece a continuación

OPTION 1  
OPTION 1  
OPCIÓN 1

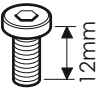
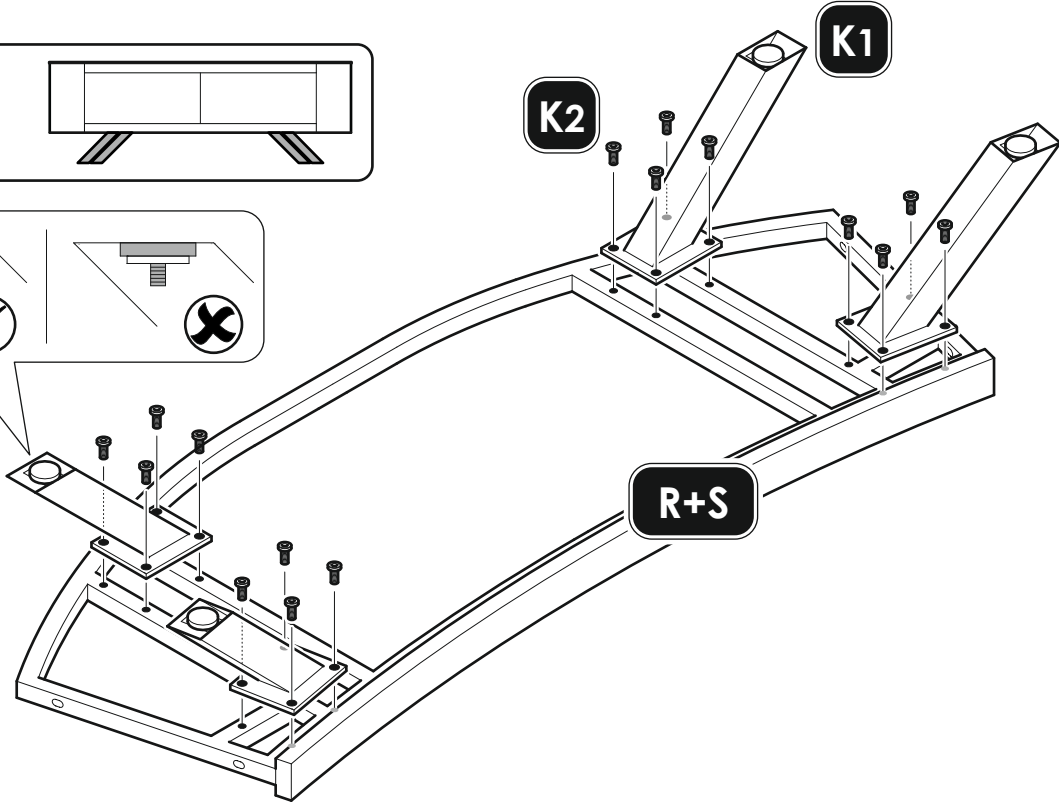
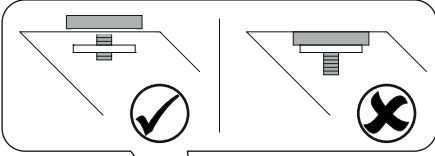
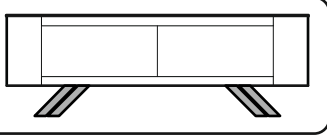

M6

**K2**

x16

OPTION 2  
OPTION 2  
OPCIÓN 2

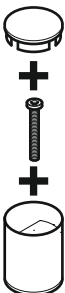
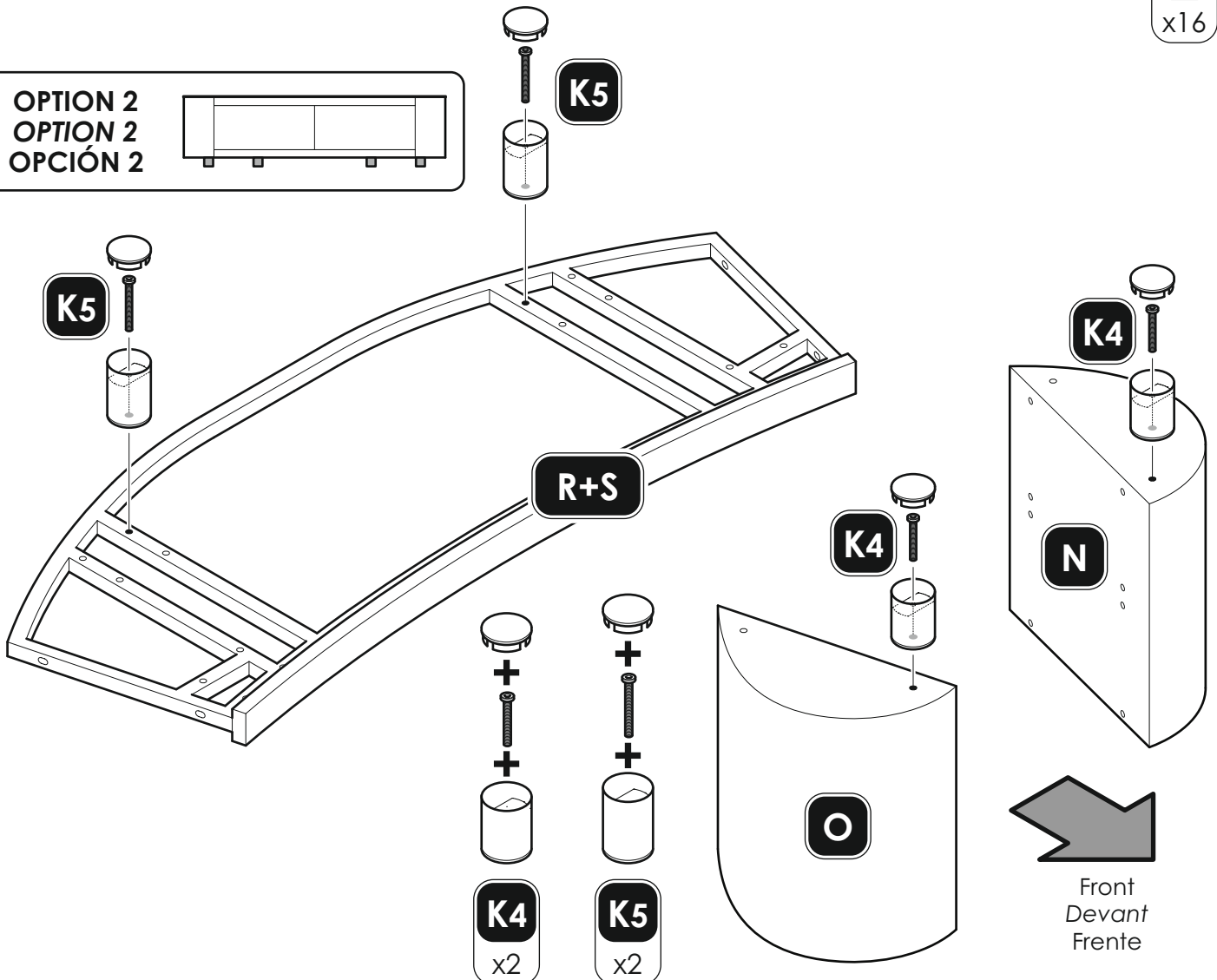
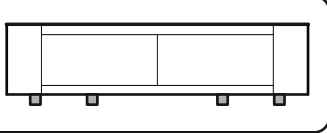

**K4**

x2

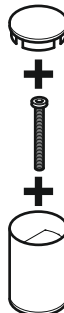

**K5**

x2

Front  
Devant  
Frente

OPTION 3  
 OPTION 3  
 OPCIÓN 3

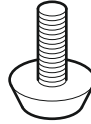
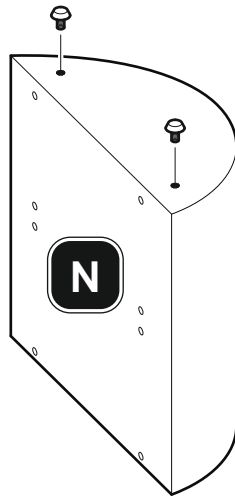
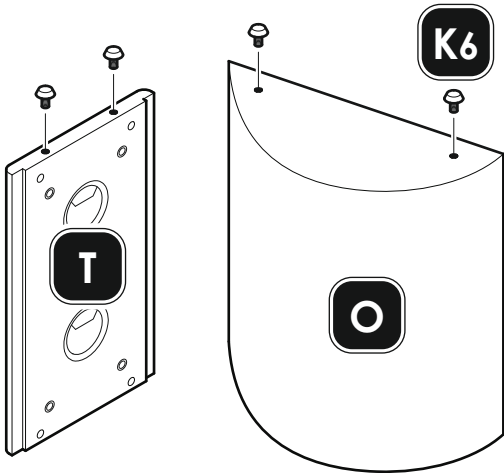
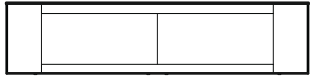

**K6**

x6



Please note, construction is the same regardless of the foot option you have chosen. Option 1 is shown for illustrative purposes.

*Veuillez noter que la construction est la même qu'importe le pied que vous avez choisi. L'option 1 est démontrée à des fins d'illustration seulement*

*Tenga en cuenta que la construcción es la misma, independientemente del tipo de pata que haya elegido. La opción 1 se muestra con fines ilustrativos*

**5**

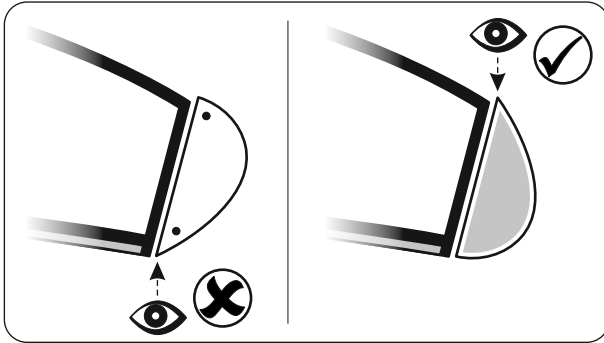

Do not fully tighten part C until step 7  
 Ne serrez pas complètement la pièce C avant l'étape 7  
 No apriete totalmente la parte C hasta el paso 7

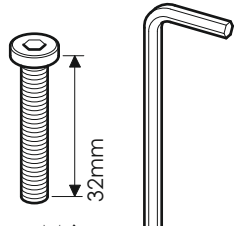
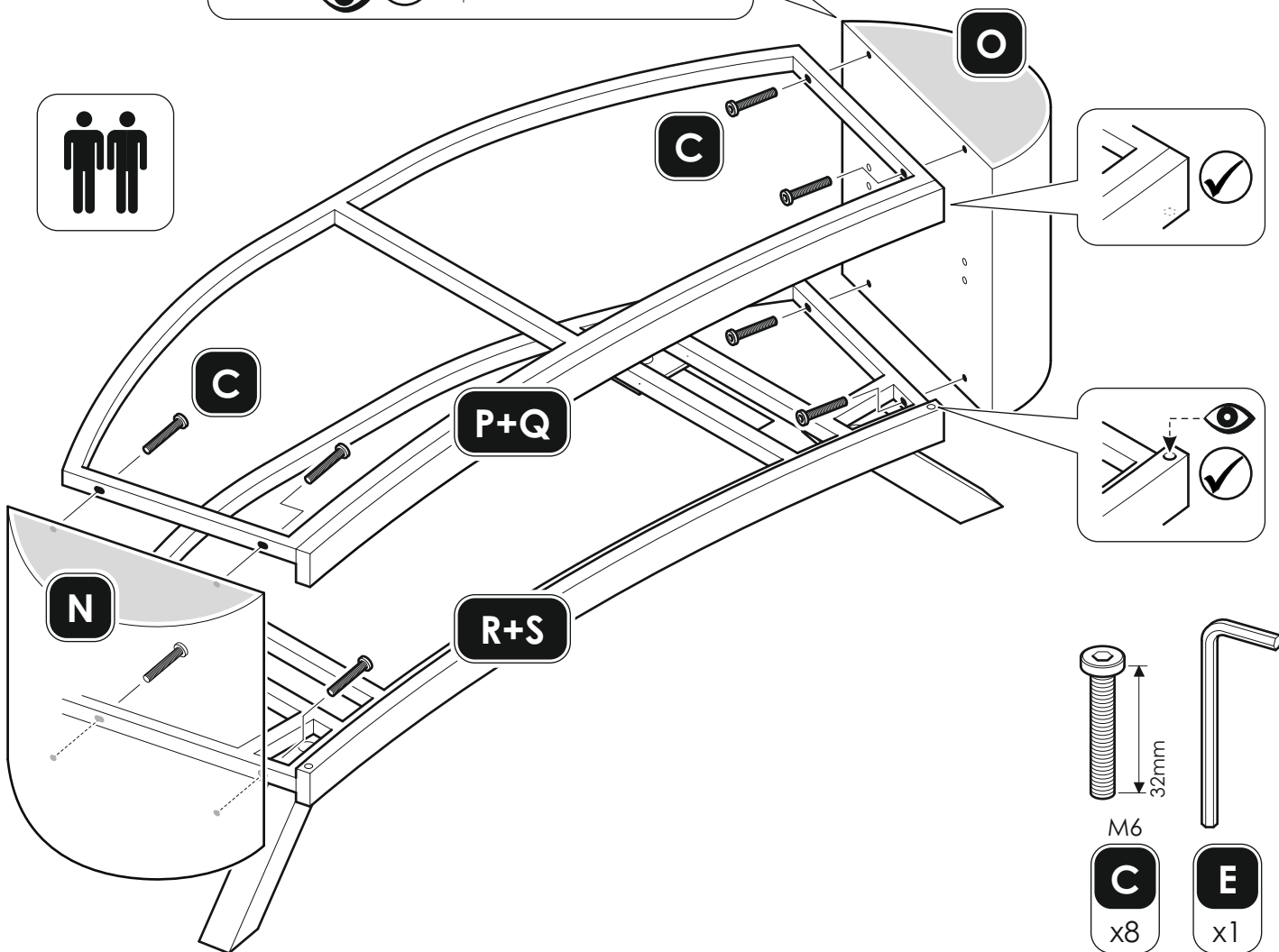

M6

**C**  
x8

**E**  
x1



# 6

Doors are optional  
 Les portes sont optionnelles  
 Las puertas son opcionales

**!**  
 Take care  
 Faire attention  
 Tenga cuidado

**!**  
 Do not over tighten  
 Ne serrez pas trop fort  
 No apriete demasiado

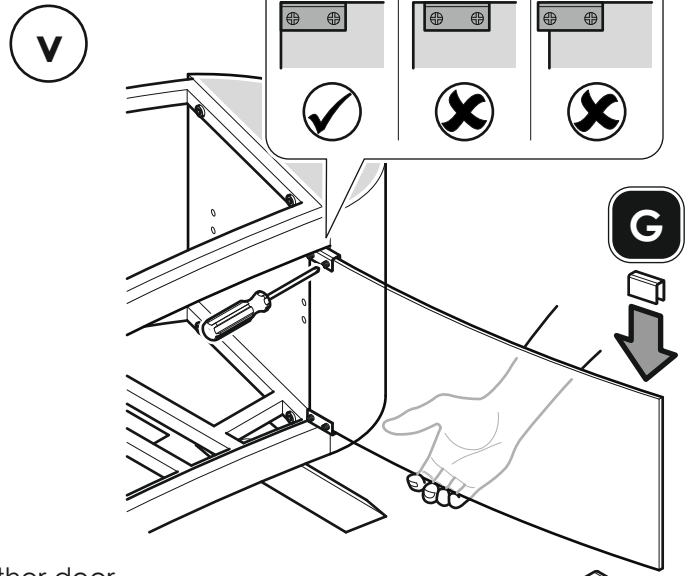
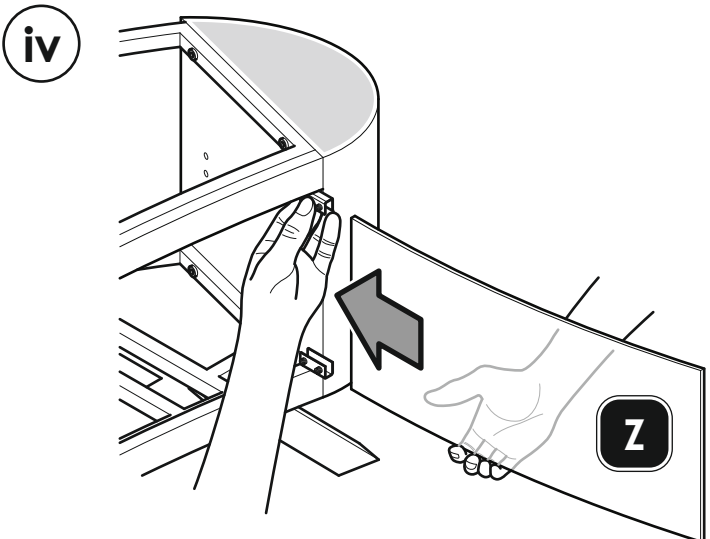
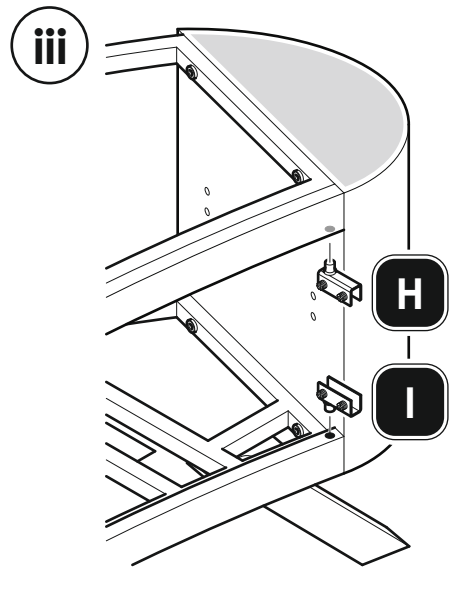
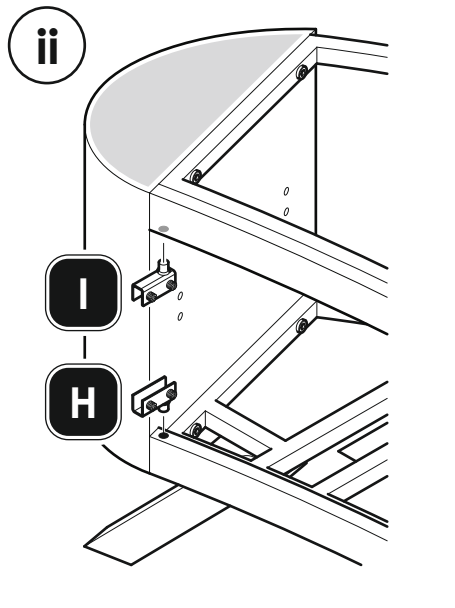
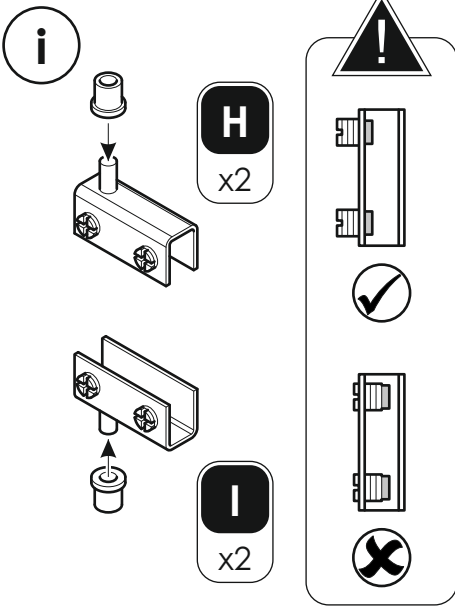

Repeat for other door  
 Recommencer pour l'autre porte  
 Repetir para la otra puerta

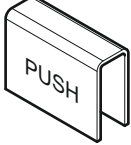

**G**  
 x2

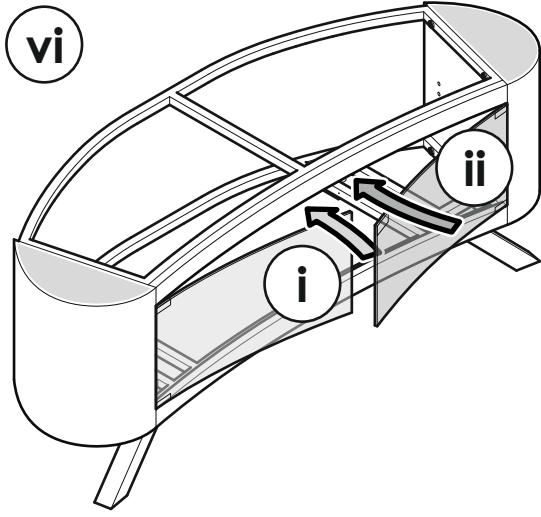



7

i

Small adjustments maybe required to align the unit and doors (if used).

To do this you can move panels **P+Q** and **R+S**

*De légers ajustements pourront être requis pour aligner l'unité avec les portes (si utilisées).*

*Pour ce faire, déplacez les panneaux **P et Q**, et **R et S***

Es posible que se requieran pequeños ajustes para alinear la unidad y las puertas (si se utilizan).

Para hacer esto, puede mover los paneles **P+Q** y **R+S**

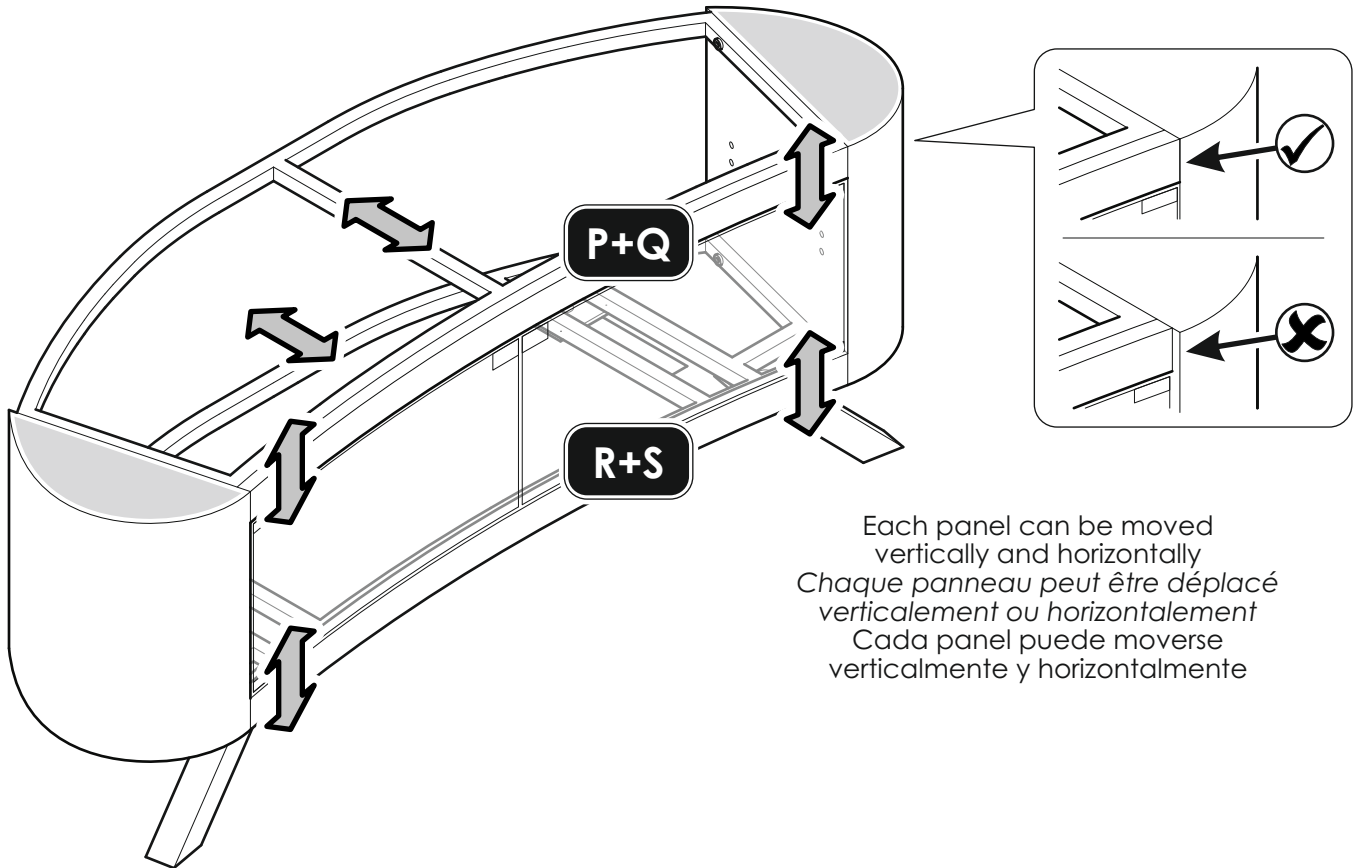

Each panel can be moved vertically and horizontally  
*Chaque panneau peut être déplacé verticalement ou horizontalement*  
Cada panel puede moverse verticalmente y horizontalmente

i

When you are happy that the unit is square and level, complete final tightening

*Lorsque l'unité est d'équerre et nivelée,*

*procédez au serrage final*

Cuando esté satisfecho de que la unidad esté cuadrada y nivelada por completo, apriétela finalmente

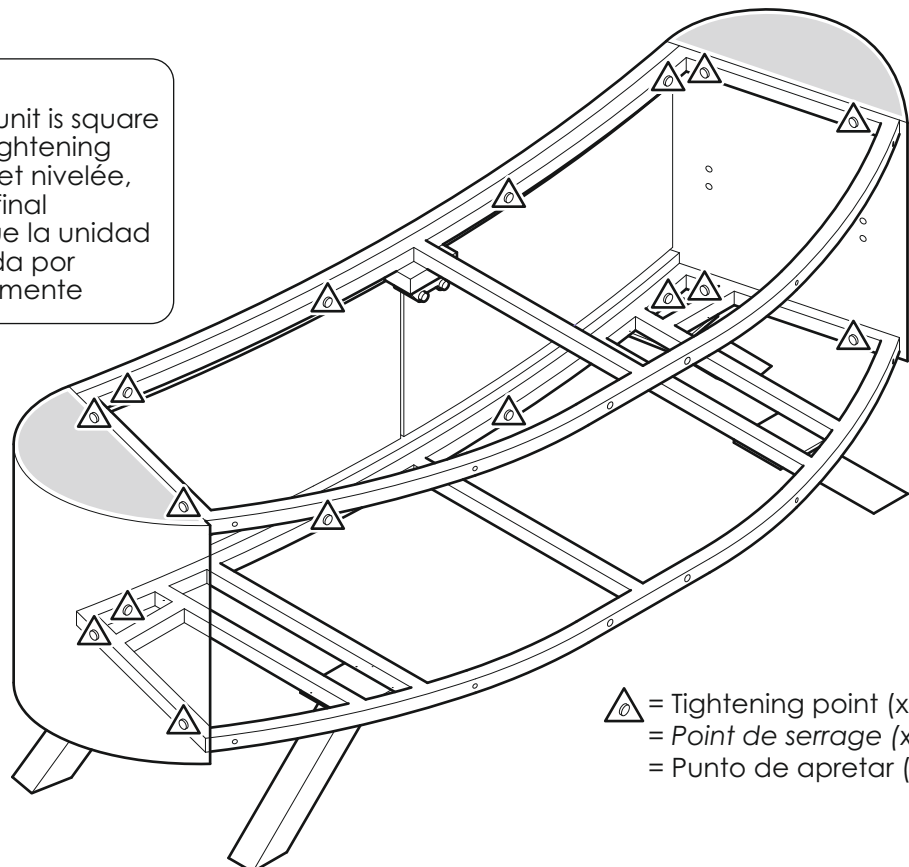

△ = Tightening point (x16)  
= Point de serrage (x16)  
= Punto de apretar (x16)

8

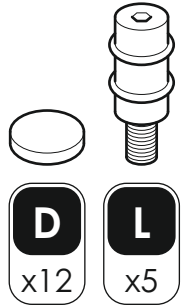
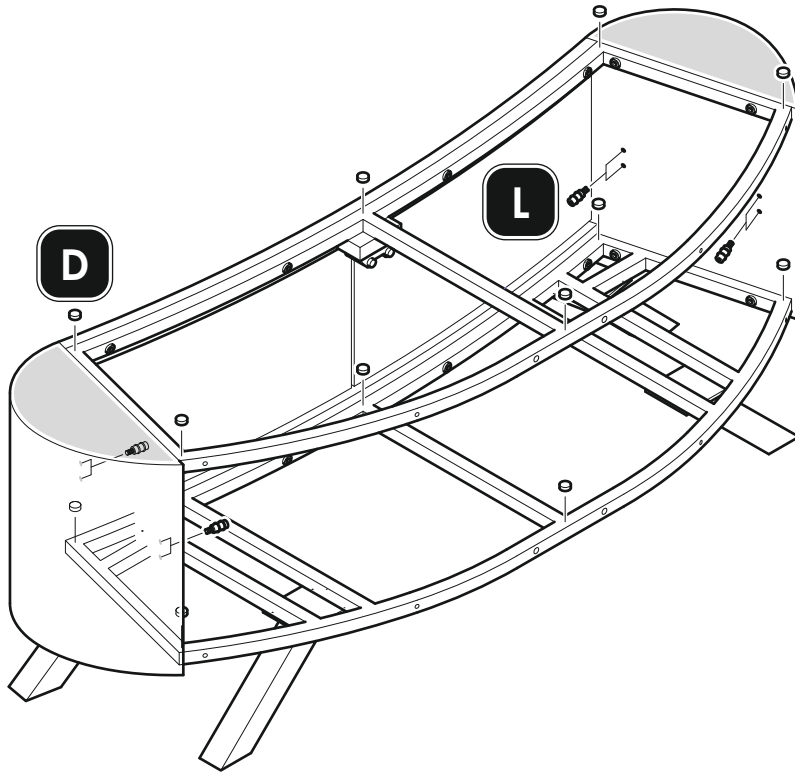
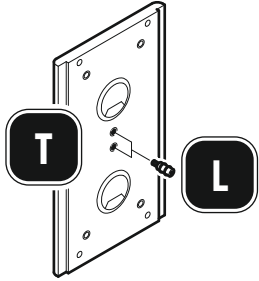

9

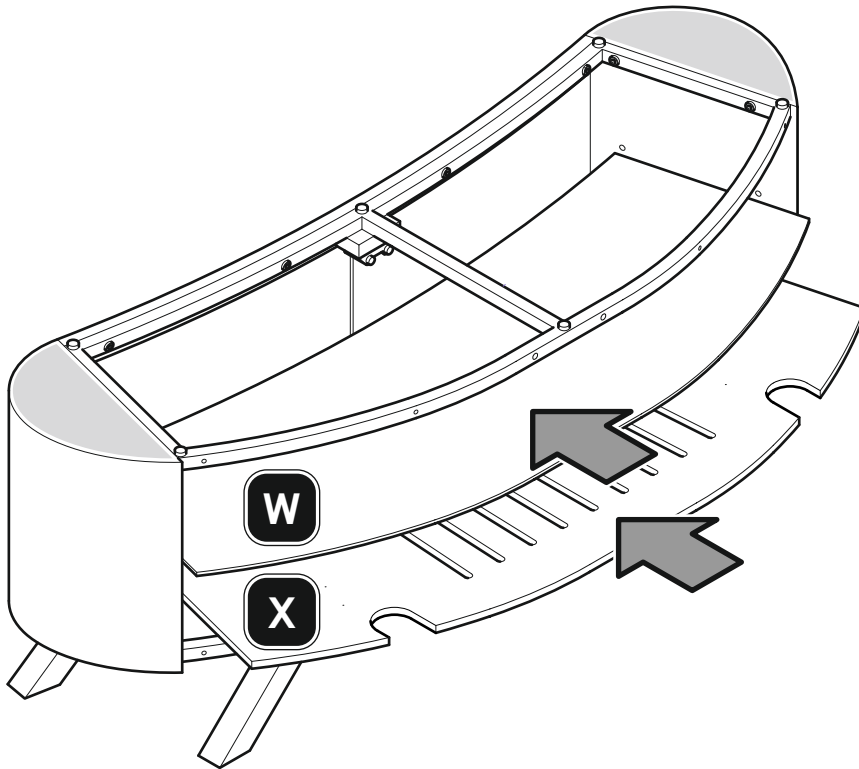

10



Panels **U** are optional  
 Les panneaux **U** sont optionnels  
 Los paneles **U** son opcionales

Panels **U** are reversible  
 Les panneaux **U** sont réversibles  
 Los paneles **U** son reversibles

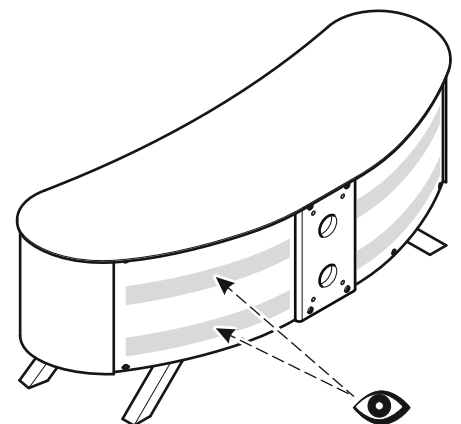
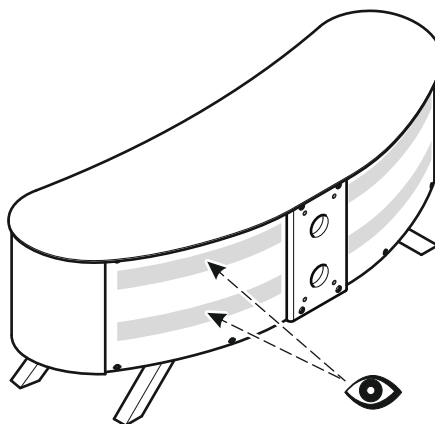

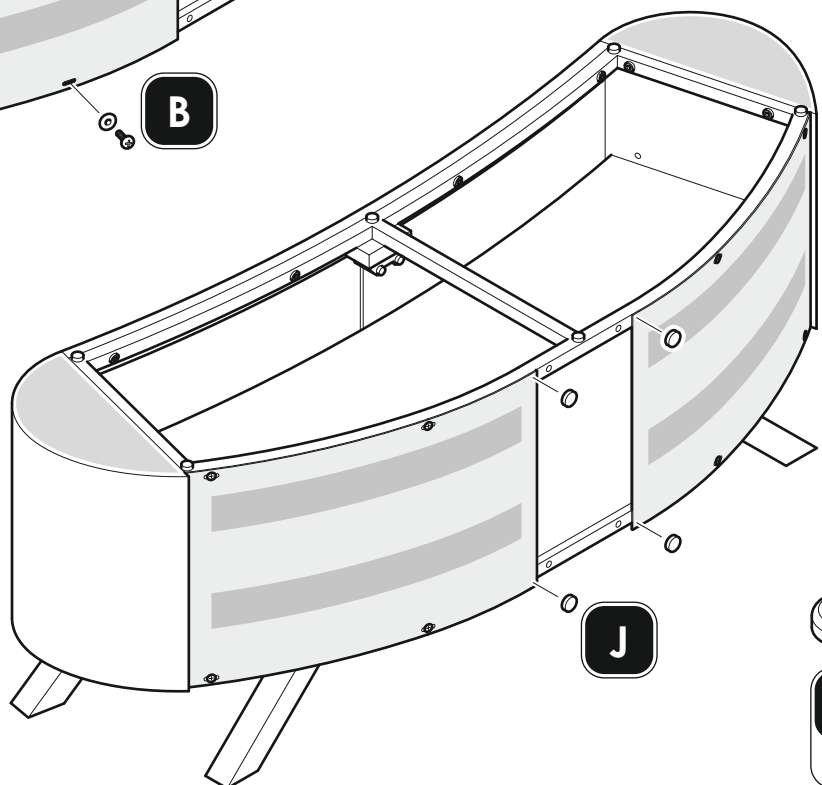
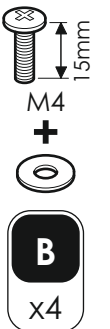
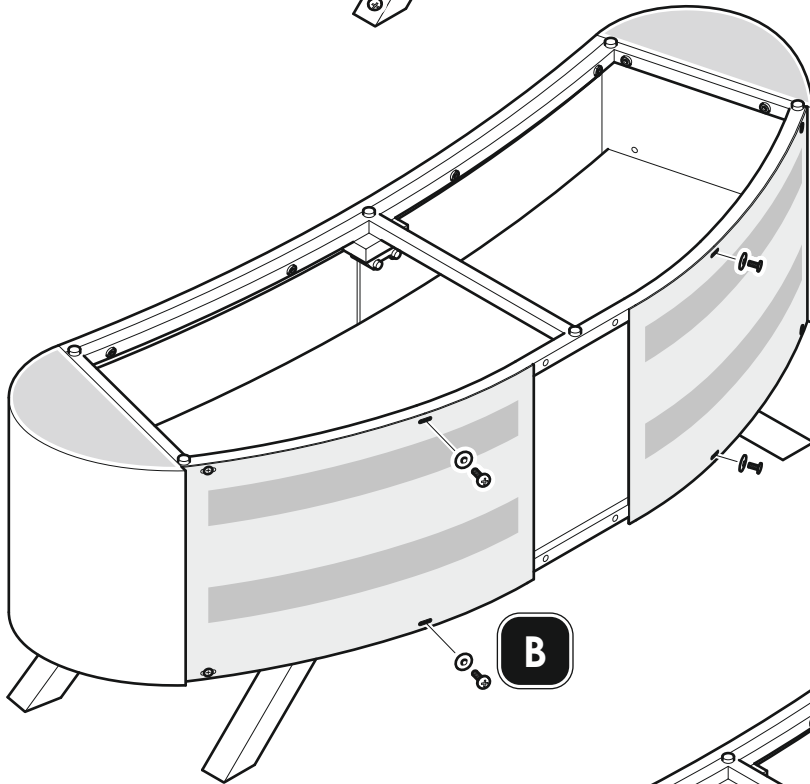
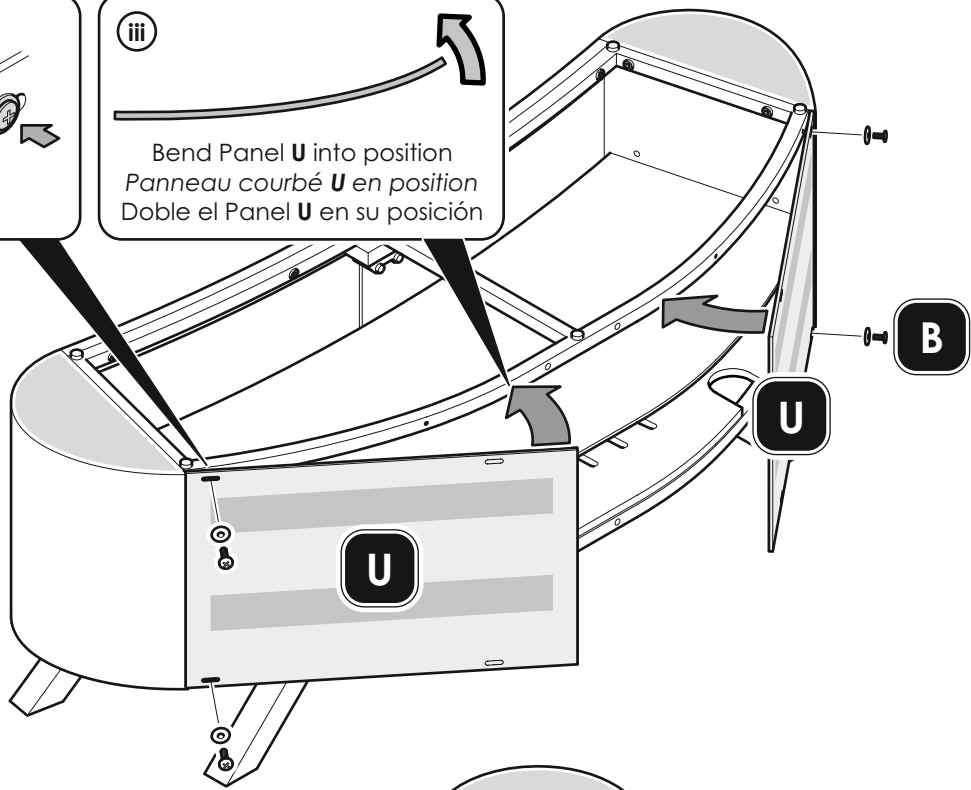
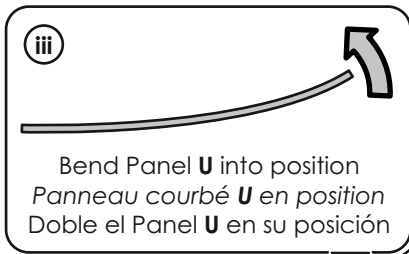
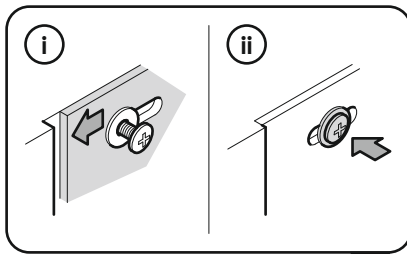

11

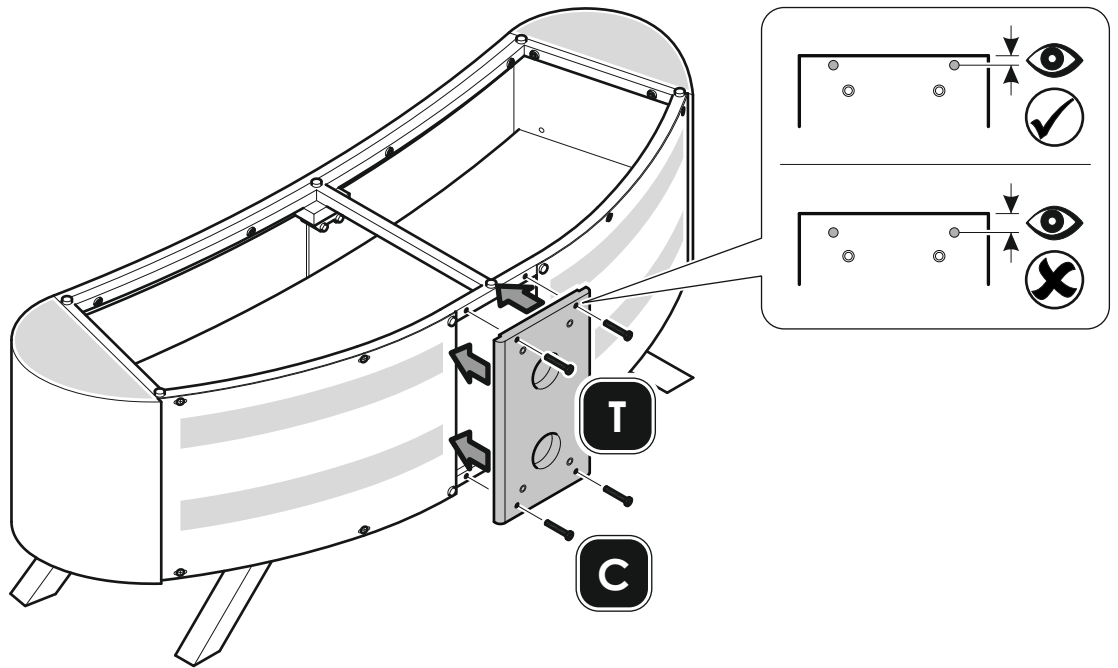
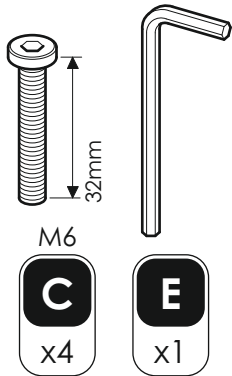

12

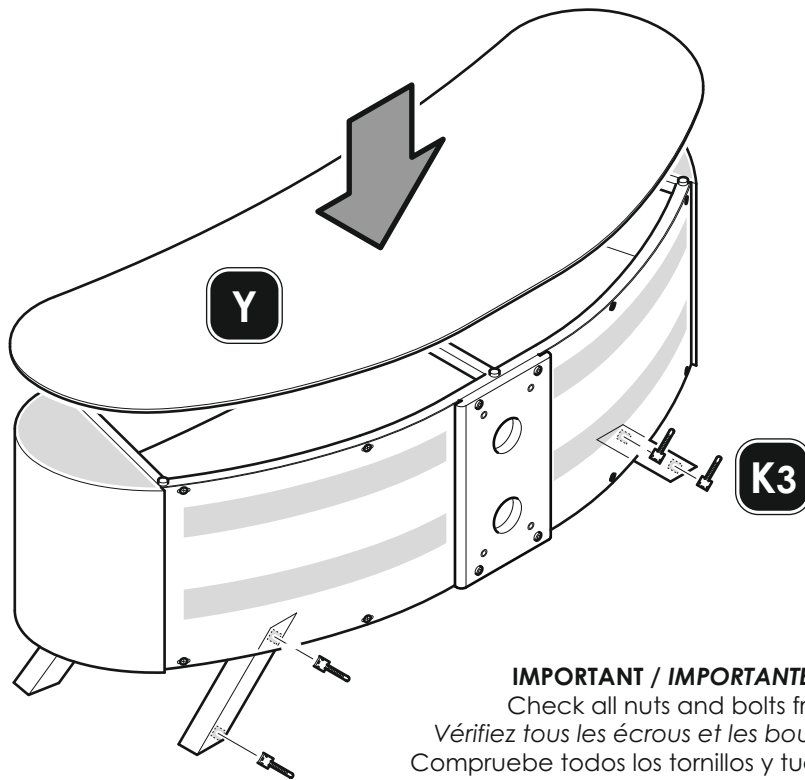

**IMPORTANT / IMPORTANTES / IMPORTANTE**  
 Check all nuts and bolts from time to time.  
 Vérifiez tous les écrous et les boulons de temps à autre.  
 Compruebe todos los tornillos y tuercas de vez en cuando.

## FL602KIT

If you are attaching column mount FL602KIT you will need to use the fixing types shown, for example **Type A** etc. Please see the FL602KIT instructions for more information.

Si vous fixez le support colonne FL602KIT, vous devrez utiliser les types d'attache montrés, par exemple **Type A** etc. Veuillez lire les instructions de FL602KIT pour plus d'informations.

Si va a colocar el soporte de columna FL602KIT, tendrá que utilizar los tipos de fijación que se muestran, por ejemplo **Tipo A** etc. Consulte las instrucciones de FL602KIT para obtener más información.

