

CNL454-E

English language / Idioma Español

Leaflet No. / No. de folleto **465395** rev 00

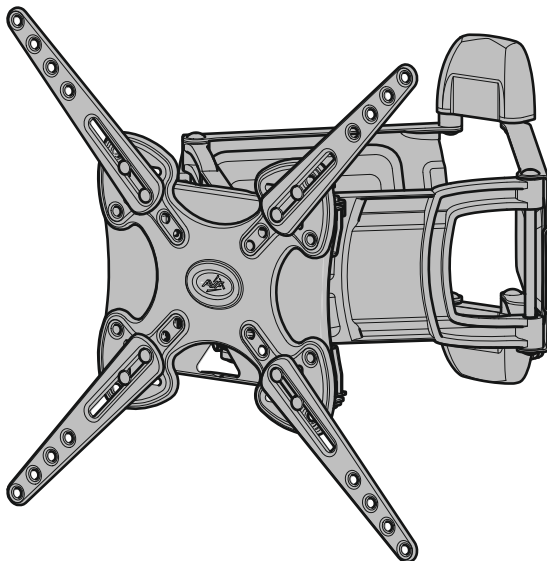

Read through ALL instructions before commencing installation.
If you have any questions about this product or issues with installation contact the customer services help line before returning this product to the store.
See www.cmx.avfgroup.com for installation video



Lea todas las instrucciones antes de comenzar la instalación.
Si tiene alguna pregunta sobre el producto o problemas con la instalación. llame a la línea de servicio al consumidor antes de devolverlo.
Vea www.cmx.avfgroup.com para el video de instalación



SOPORTE PARA TV DE PANEL PLANO

ITM./ART.: 732194 Modelo: CNL454-E

Para televisores de 56 cm (22 pulg.) a 119 cm (47 pulg.) Soporta un Peso de hasta 40 kg

Herramientas recomendadas:

- Broca para Mampostería 9,5mm - Broca para Madera 3mm

Tornillos de Televisor y Reductores: M4 16mm, M4 25mm

M5 16mm, M5 25mm, M6 16mm, M6 25mm, M6 45mm, M8 16mm, M8 25mm y M8 45mm

Orificios de Televisor: Ancho mínimo 75mm máximo 400mm –Alto mínimo 75 mm máximo 400mm

De ser necesario puede utilizar los espaciadores I1 y I2

Importado por: Importadora Primex, S.A. de C.V.

Bldv. Magnocentro No. 4 San Fernando La Herradura Huixquilucan, Estado de México, C.P. 52765

RFC: IPR-930907-S70 Tel: (5) 246-5500 www.costco.com.mx

Assembly Overview Ensambladura General



2 Person Installation Recommended
Instalación De 2 Personas Recomendado

Fit the TV Mounting Plate
Fije La Placa De Montaje De TV

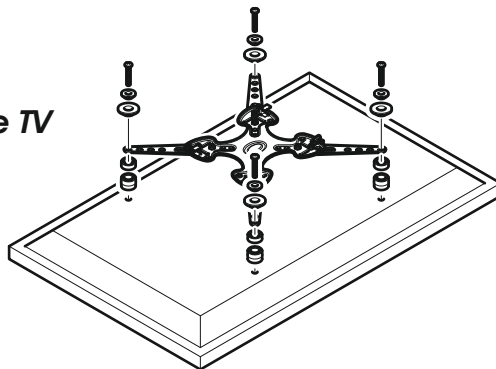

Fit the Wall Bracket
Fije el Soporte de Pared

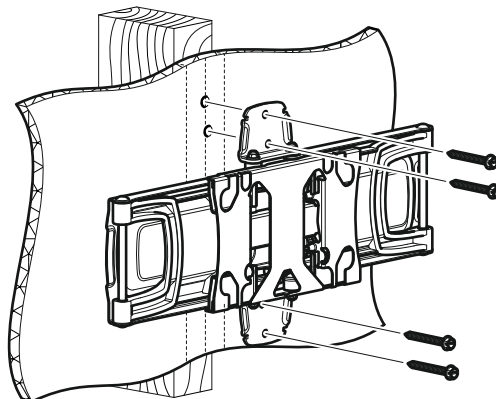

Connect the TV
Conecte la TV

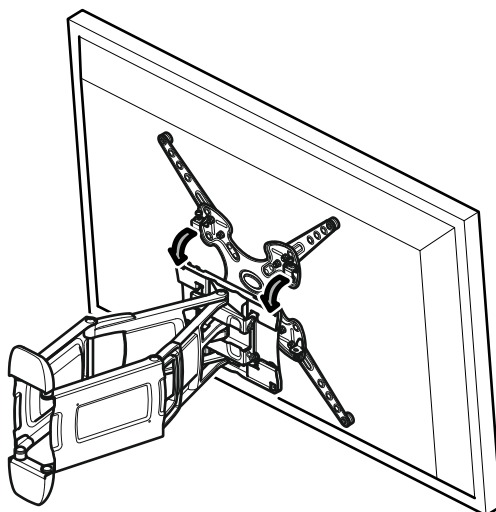

Index Índice

1 Measure the TV fixing holes Width and Height
Mida los orificios de su TV, lo ancho y lo alto

2 Preparing the Front Adaptor Plate
Preparando La Placa Adaptadora Frontal

3 Preparing the TV Mounting Plate
Preparando La Placa De Montaje De TV

4 Fitting the TV Mounting Plate
Fijando La Placa De Montaje De TV

5 Fitting the Wall Bracket
Fijando la Placa a la Pared

6 Fitting the Wall Bracket Covers
Fijando Las Cubiertas Del Soporte De Pared

7 Connecting the TV
Conectando la TV

8 Cable Management
Manejo de Cable

Retain all packaging in case the bracket needs to be returned.

Contents may vary from photography/ Illustrations.

You will not need all these parts, so expect there to be some left over depending upon the specification of your TV.

This product is intended for indoor use only. Use of this product outdoors could lead to failure and personal injury.

It is the responsibility of the installer to ensure that the mounting wall is of a suitable standard and void of any services (eg gas, electricity, water etc).

AVF accept no responsibility for any damage or loss caused by installing this product in a sub standard wall.

*Conserve todos los envasados en caso de que el soporte tenga que ser devuelto.
El contenido puede variar de la fotografía / ilustración.*

No necesitará todas estas partes, espere que sobren algunas según las especificaciones de su TV.

Este producto está diseñado para el uso en el interior solamente. El uso de este producto en el exterior podría llevar al fracaso y lesiones personales.

Es la responsabilidad del instalador de asegurarse de que la pared de montaje es de un nivel adecuado y carece de todo los servicios (gas, electricidad, agua, etc.).

AVF no acepta ninguna responsabilidad por cualquier daño o pérdida causada por la instalación de este producto en una pared inadecuada.

Tools Recommended
Herramientas recomendadas

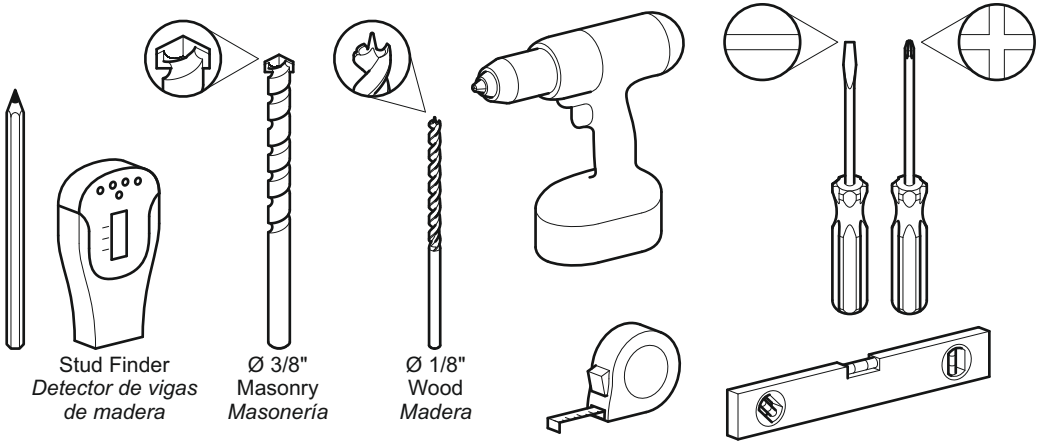

Boxed Parts
Piezas en la Caja

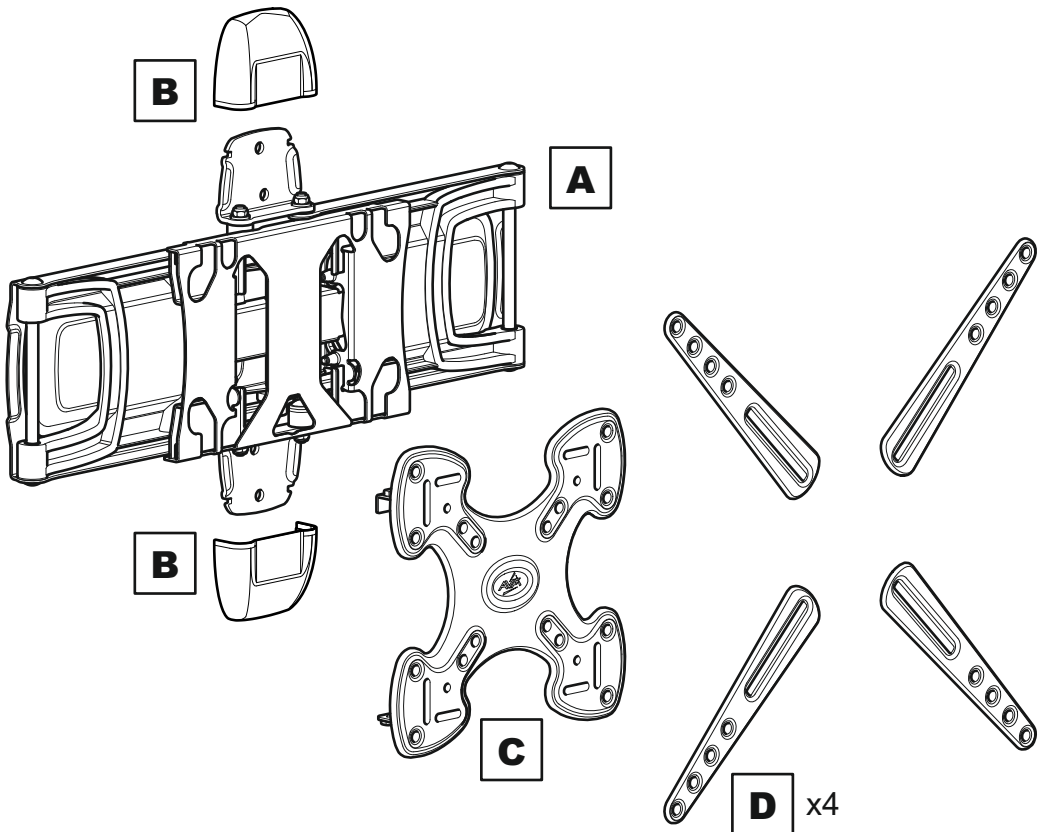

TV Screws, Reducers and Spacers

Tornillos, Reductores y Espaciadores para TV

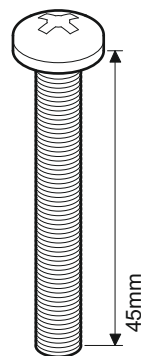

M6
J7 x4

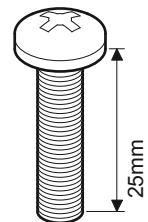

M6
J6 x4

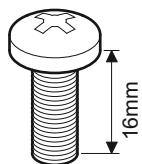

M6
J5 x4

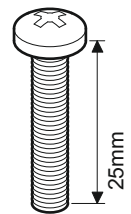

M5
J4 x4

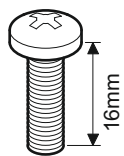

M5
J3 x8

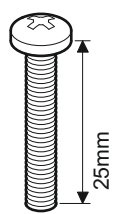

M4
J2 x4

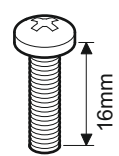

M4
J1 x4

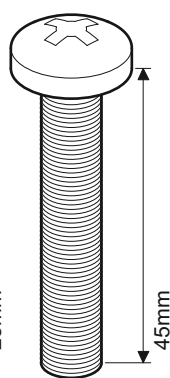

M8
J10 x4

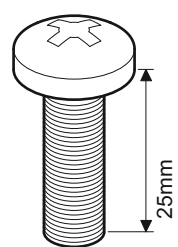

M8
J9 x4

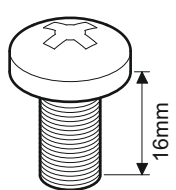

M8
J8 x4



H1 x4



H2 x4



I1 x12



I2 x4

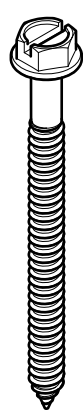

K x4

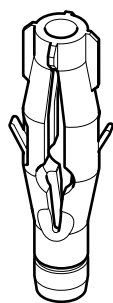

L x4

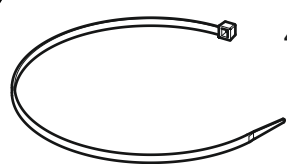

M x4



N x1



E x8



F x8



G x16

1 Measure the TV fixing holes Width and Height Mida los orificios de su TV, lo ancho y lo alto

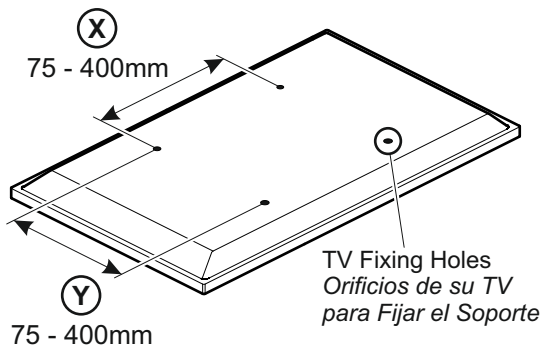

If width (X) is greater than 400mm or height (Y) greater than 400mm STOP installation now and contact the customer help line

Si la anchura (X) es mayor que 400mm o la altura de (Y) es mayor que 400mm DETENGA la instalación inmediatamente y póngase en contacto con la línea de ayuda al cliente

You are provided with 4 diameters of TV fixing screws, **M4**, **M5**, **M6** and **M8**. Determine the screw diameter that fits and remember for step 4.

Se le proporciona con 4 diámetros de tornillos de fijación para su TV: **M4**, **M5**, **M6** y **M8**. Determine el diámetro del tornillo que le quede a su TV y recuérdelo para el paso 4..

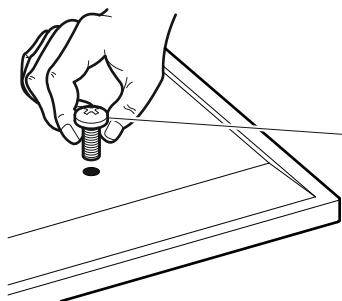

M4 = J1/J2

M5 = J3/J4

M6 = J5/J7

M8 = J8-J10



After completing step 4 you will have fittings left over, please keep for future reference
Después de completar el paso 4 usted tendrá conexiones sobrantes, por favor guarde para futura referencia.

2 Preparing the Front Adaptor Plate Preparando La Placa Adaptadora Frontal

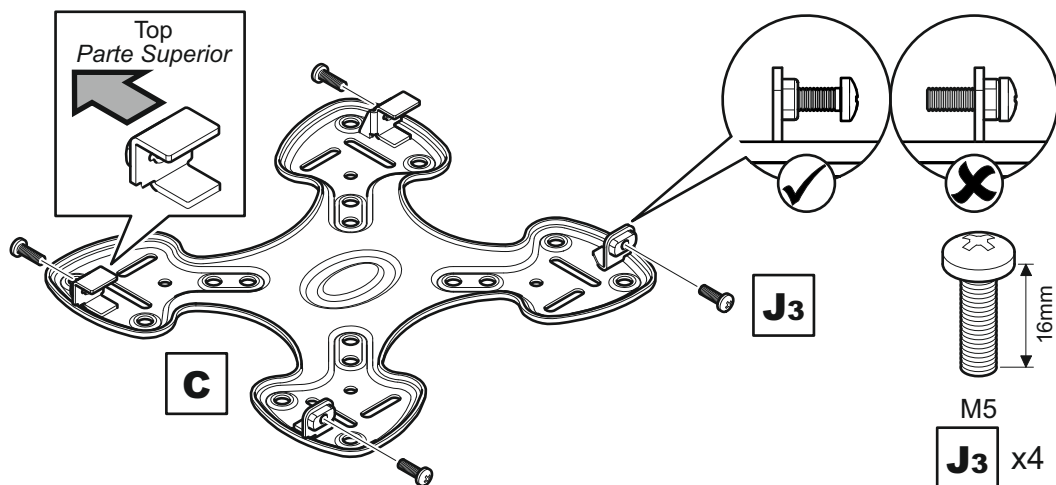

3

Preparing the TV Mounting Plate *Preparando La Placa De Montaje De TV*

Use the option that fits your TV / *Utilice la opción que mejor se adapte a su TV*
Do not fully tighten / *No ajuste completamente*

OPTION 1 / OPCIÓN 1

- | | |
|-----------|-----------|
| (X) 75mm | (Y) 75mm |
| (X) 100mm | (Y) 100mm |
| (X) 200mm | (Y) 100mm |
| (X) 200mm | (Y) 200mm |

OPTION 2 / OPCIÓN 2

- | | | | |
|-----------|-----------|----------------|----------------|
| (X) 300mm | (Y) 100mm | (X) 400mm | (Y) 200mm |
| (X) 300mm | (Y) 200mm | (X) 400mm | (Y) 300mm |
| (X) 300mm | (Y) 300mm | (X) 400mm | (Y) 400mm |
| (X) 400mm | (Y) 100mm | (X) 75 - 400mm | (Y) 75 - 400mm |

If in any doubt please call the customer help line.

Si tiene alguna duda, comuníquese con la línea de atención al cliente.

OPTION 1 / OPCIÓN 1

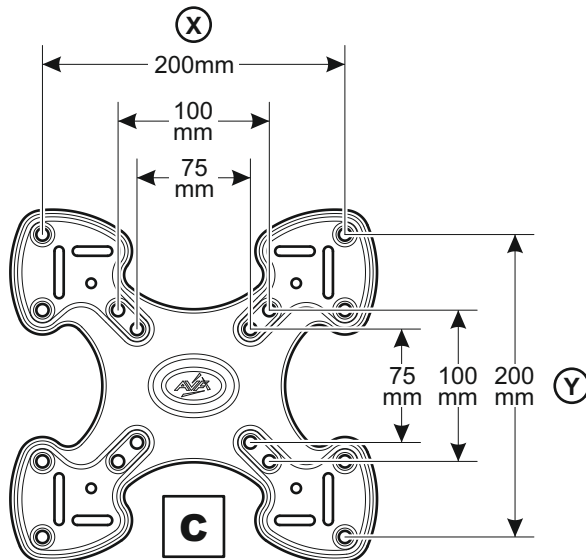

If your TV fixing holes match any of the sizes shown above you will not need to use any adaptors. Please go to step 4.

Si los orificios de ajuste del TV coinciden con cualquiera de los tamaños que se indican arriba, no necesitará utilizar adaptadores. Continúe con el paso 4

OPTION 2 / OPCIÓN 2



When attaching adaptors **D** you must always use **HOLES x4** and either of the **SLOTS**.

*Para colocar adaptadores **D** deberá siempre utilizar **ORIFICIOS x4** y alguna de las **RANURAS**.*

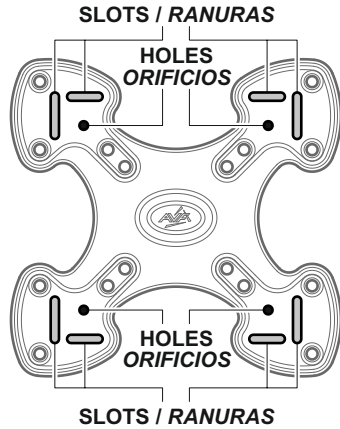

Top
Parte Superior

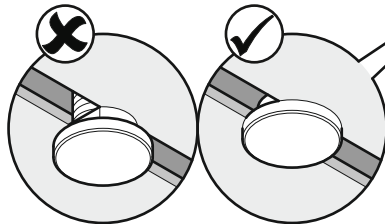
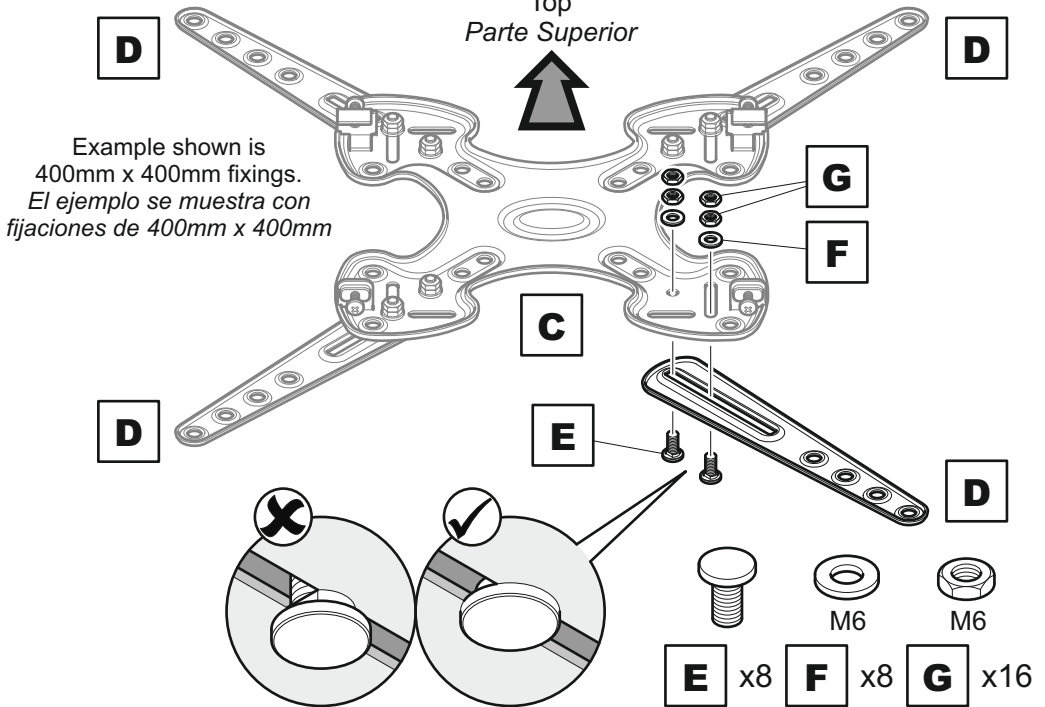

● = HOLES / ORIFICIOS
○ = SLOTS / RANURAS

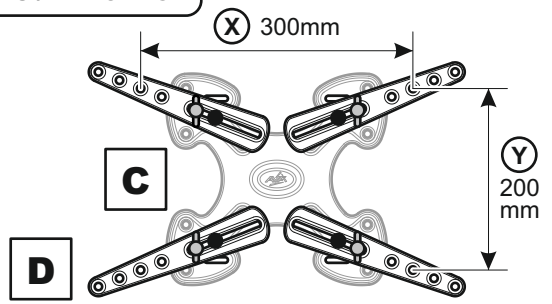
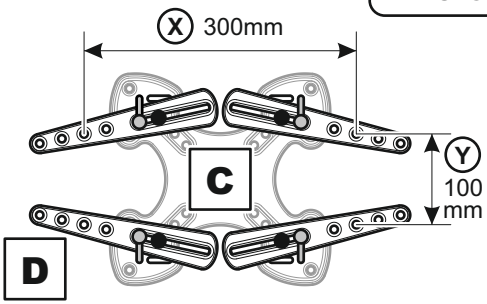

● = HOLES / ORIFICIOS
○ = SLOTS / RANURAS

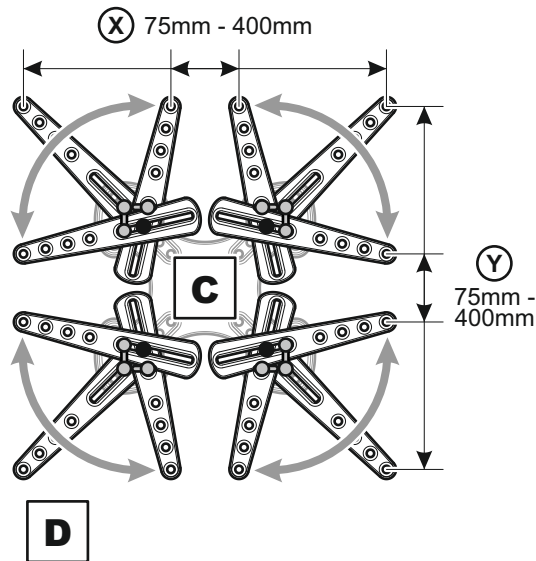
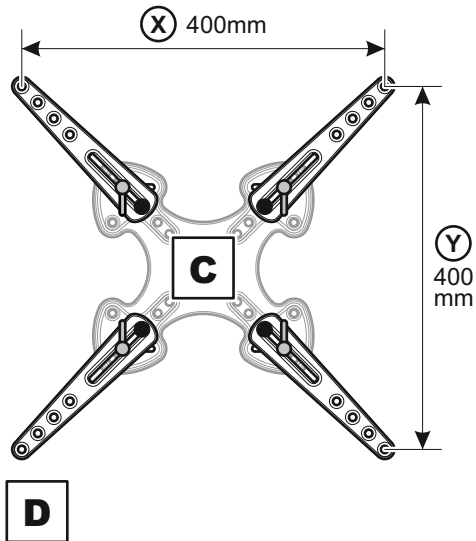
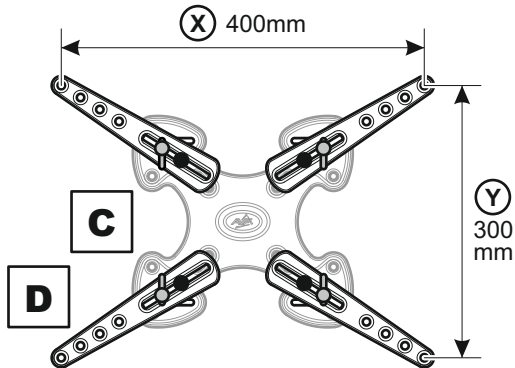
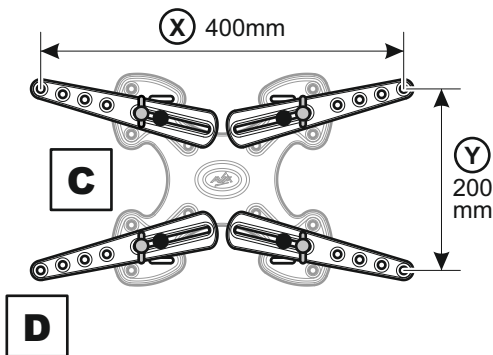
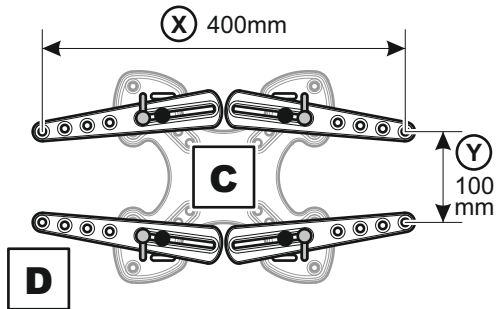
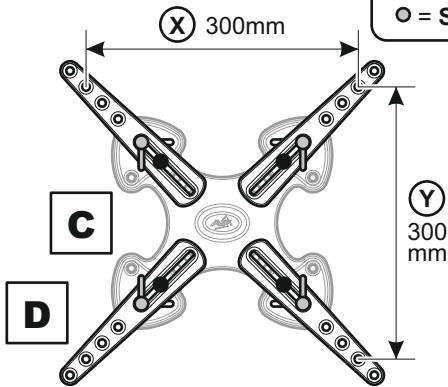

Adaptors **D** can be fixed in different positions in the slots on Plate **C** to match your TV fixing holes.
*Los adaptadores **D** pueden fijarse en diferentes posiciones en las ranuras de la placa **C** para que coincidan con los orificios de fijación de su televisor.*

4

Fitting the TV Mounting Plate Fijando la Placa de Montaje a su TV

Before you fully tighten the TV mounting plate please check that the mounting plate holes line up with the fixing holes on the back of your TV.

Antes de fijar completamente la placa de montaje de TV verifique que los orificios de la placa de montaje coincidan con los orificios en la parte posterior de su TV

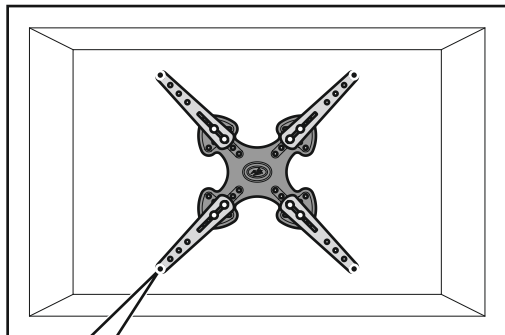

Holes do not line up and small adjustment is required before you fully tighten
Los orificios no coinciden y es necesario hacer un pequeño ajuste antes de fijar completamente

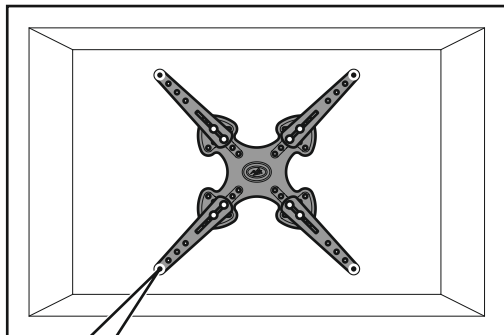

Holes line up and no adjustment is required before you fully tighten
Los orificios coinciden y no es necesario hacer ningún ajuste antes de fijar completamente

No Spacers Sin espaciadores

For TVs with flat/
unobstructed back
Para TVs con la parte posterior plana / sin obstáculos

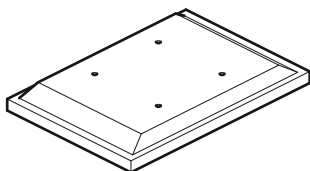

Spacers Espaciadores 1/12

For TVs with irregular/obstructed back
Para TVs con la parte posterior irregular / con obstáculos

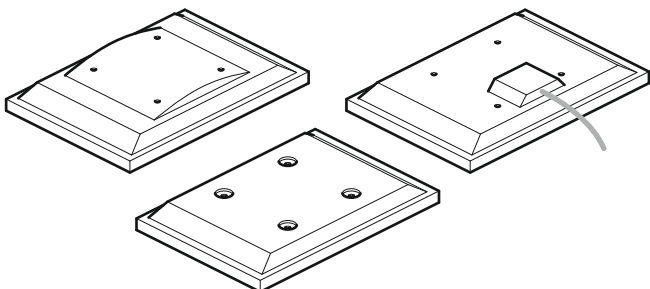

WARNING / ADVERTENCIA

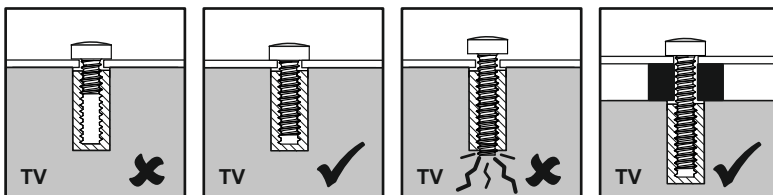

After completing step 4 you will have fittings left over, please keep for future reference.
Después de completar el paso 4 usted tendrá conexiones sobrantes, por favor guarde para futura referencia.

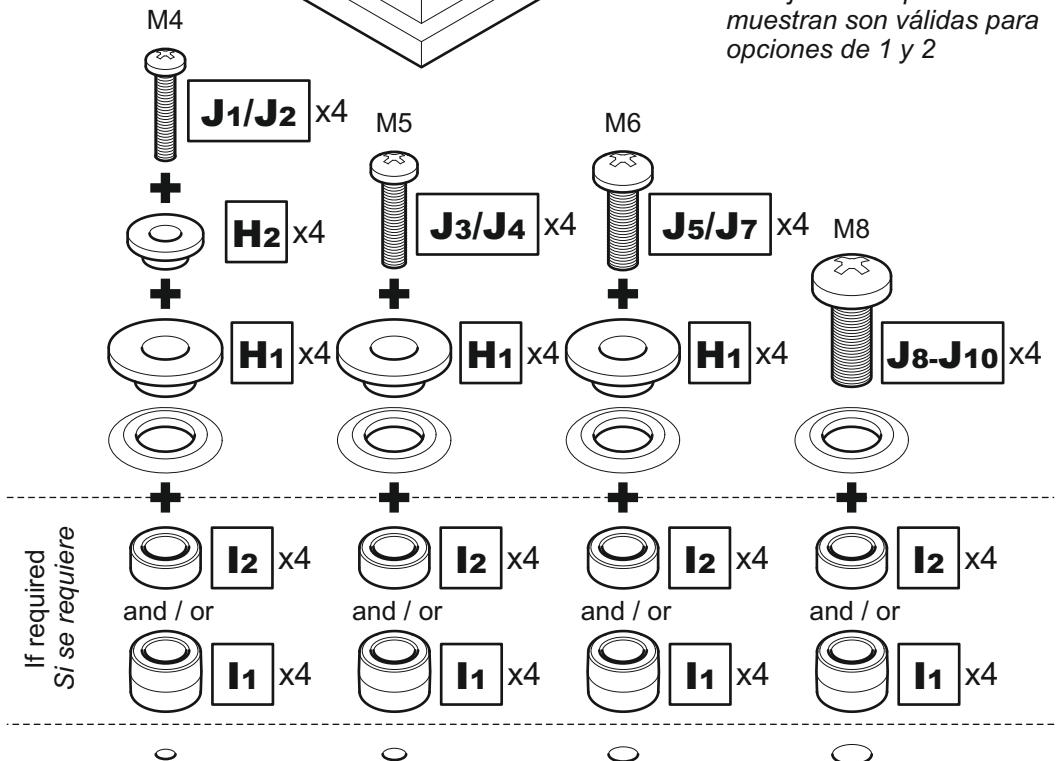
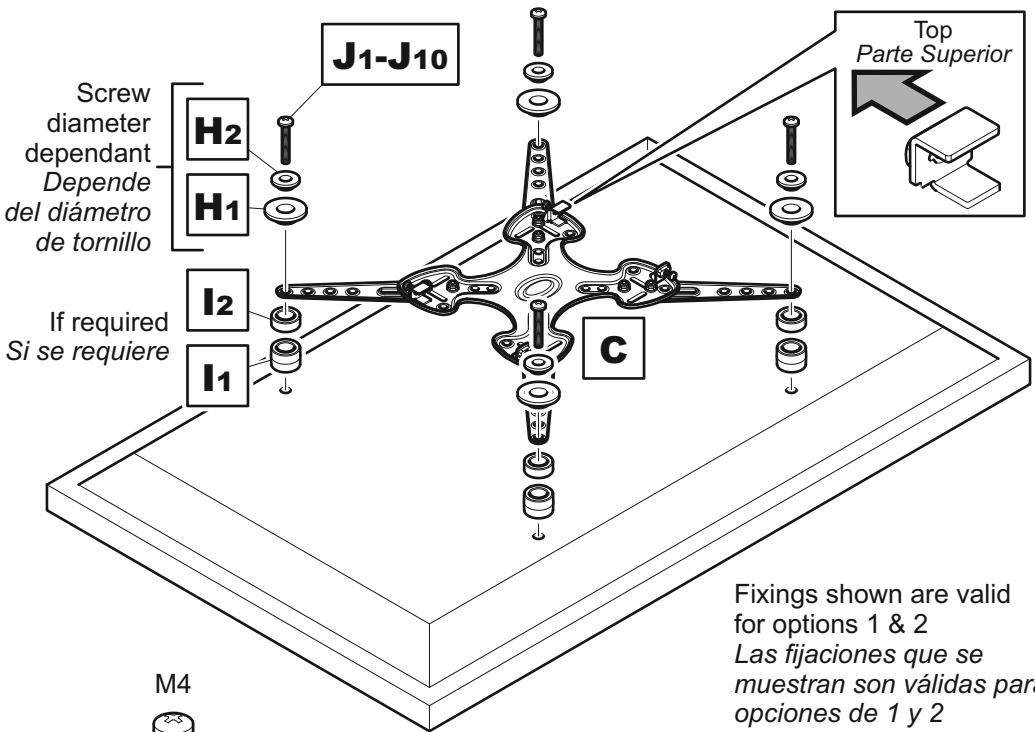

Attach the brackets to the back of your TV using suitable screw, reducer and spacer combinations.
Coloque los soportes a la parte posterior de su TV usando la combinación adecuada de tornillo, reductor y espaciador.

5 Fitting the Wall Bracket
Fijando la Placa a la Pared

Solid Wall / Pared sólida

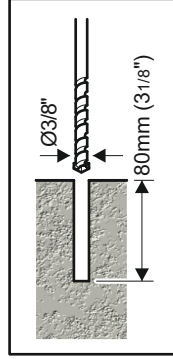
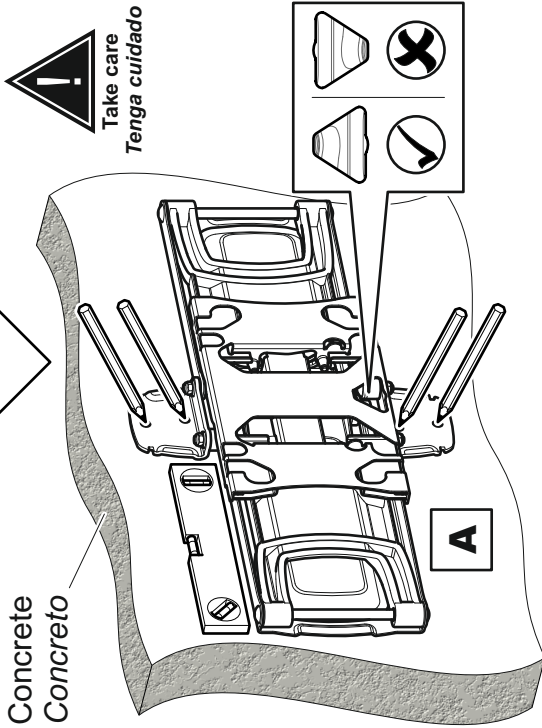

Remove dust from hole
Elimine el polvo del agujero

Wood Stud / Viga de madera

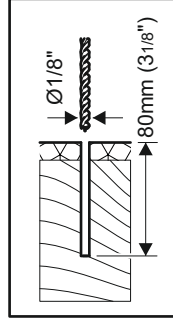
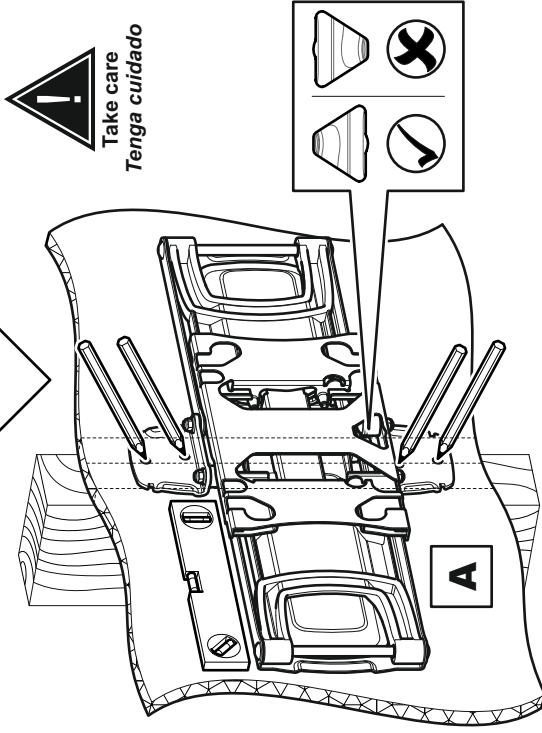

Ensure bracket is in the
 centre of the wood stud
*Asegúrese de que el
 soporte está en el centro
 de la viga de madera*

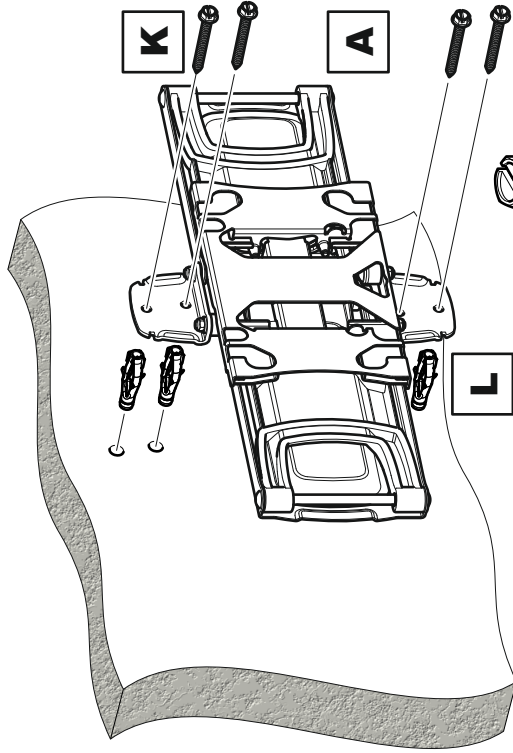
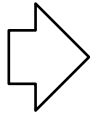

K

A

L

Lubricate screw
thread with soap
*Lubrique la rosca
del tornillo con jabón*



K x4

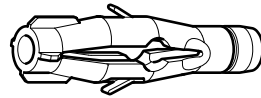

L x4



DO NOT over tighten screws
Tighten screws by hand only
NO sobre apriete los tornillos.
Apriete los tornillos sólo a mano

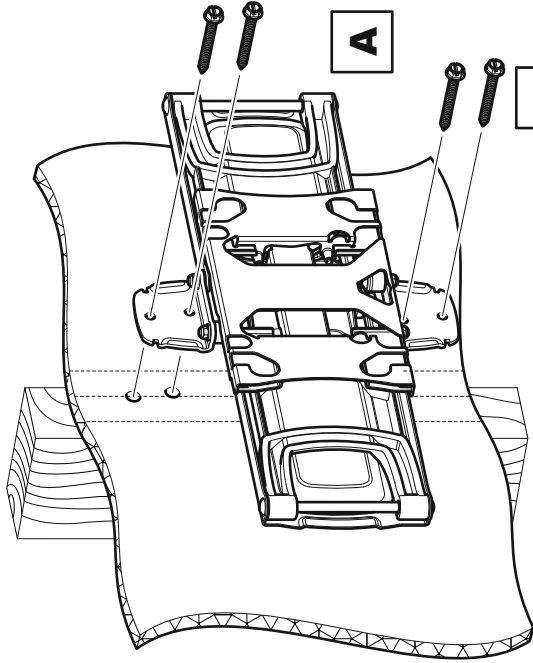
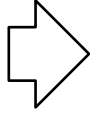

A

K

Lubricate screw
thread with soap
*Lubrique la rosca
del tornillo con jabón*

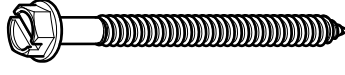

K x4



DO NOT over tighten screws
Tighten screws by hand only
NO sobre apriete los tornillos.
Apriete los tornillos sólo a mano

6

Fitting the Wall Bracket Covers *Fijando Las Cubiertas Del Soporte De Pared*

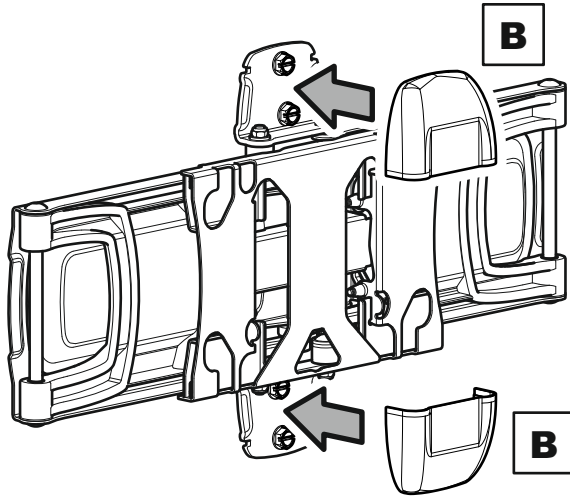
**7**

Connecting the TV *Conectando la TV*

Attaching and Locking
Sujetando y Asegurando

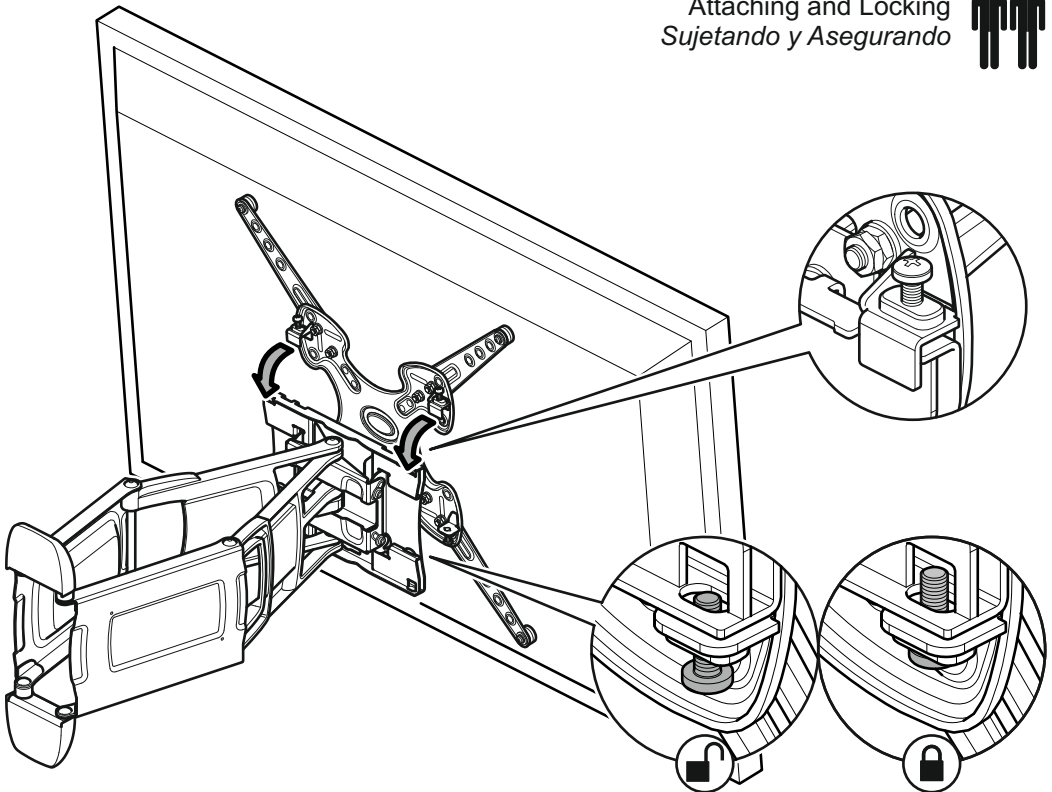

8

Cable Management Manejo de Cable

Ensure cables don't restrict arm movement
Asegure que los cables no restringen el movimiento de los brazos

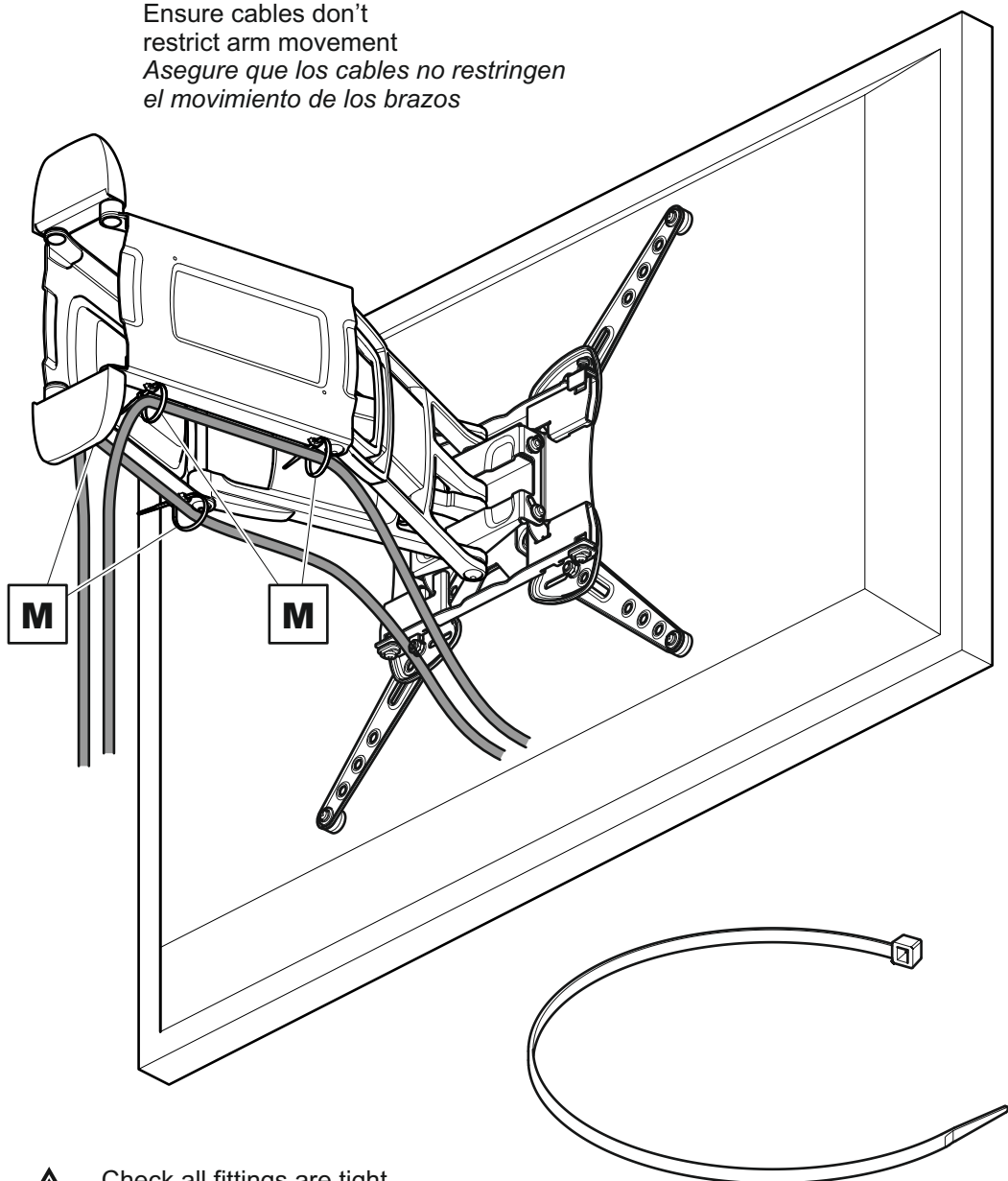

Check all fittings are tight
Compruebe que todas las fijaciones estén bien apretadas

M x4

**Optional
Opcional**

Lock tilt / Cerradura de la función de inclinación

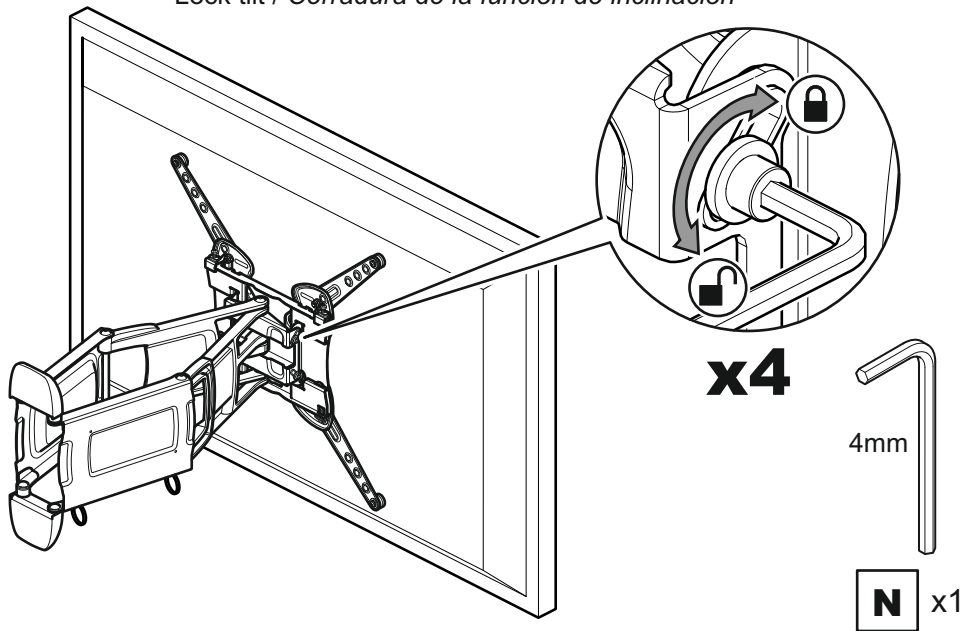

TV Levelling / Nivelación de TV

