

Read through ALL instructions before commencing installation.
If you have any questions about this product or issues with installation contact the customer services help line before returning this product to the store.
See www.avfgroup.com/unimax for instruction video.

CUSTOMER SERVICES HELP LINE NUMBER:
+44 (0) 333 320 0463 (UK)
1-800 667 0808 (USA)



1 Boxed Parts

You will not need all these parts, so expect there to be some left over depending upon the specification of your TV.

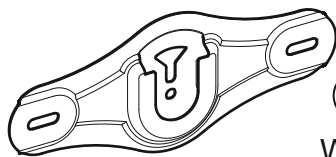

A - x1
Wall Bracket

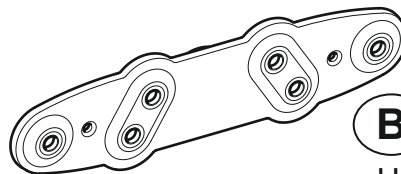

B - x1
Hanger

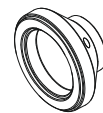

C - x2
Stand-off

TV Fixings: Parts go on the back of the TV (specification of your TV will determine which ones you require - see section 9).



D1 - x10
Spacer



D2 - x4
Spacer
(Red)



E1 - x4
M4
Adaptor



E2 - x4
M5
Adaptor



E3 - x4
M6
Adaptor



F1 - x2
M4 16mm



F2 - x2
M4 25mm

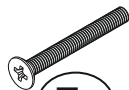

F3 - x2
M4 35mm

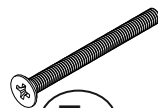

F4 - x2
M4 50mm

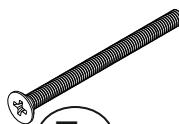

F5 - x2
M4 60mm



F6 - x2
M5 16mm



F7 - x2
M5 25mm

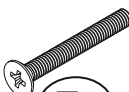

F8 - x2
M5 35mm

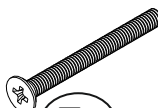

F9 - x2
M5 50mm



F10 - x2
M6 16mm



F11 - x2
M6 25mm

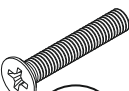

F12 - x2
M6 35mm

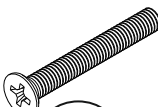

F13 - x2
M6 50mm



F14 - x2
M8 16mm



F15 - x2
M8 25mm

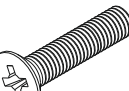

F16 - x2
M8 35mm

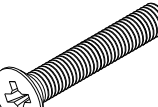

F17 - x2
M8 50mm

Wall Fixings: Parts to attach to the wall (type of wall will determine which fixings you require).



G - x2
Wall Fixing

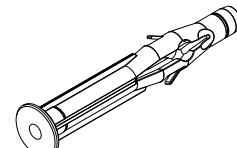

H - x2
Long Wall Plug



I - x4
Lock Nut

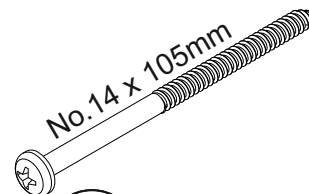

J - x2
Long Screw



K - x1
Metal
Stud Screw

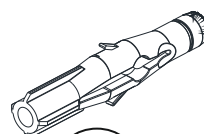

L - x2
Wall Plug

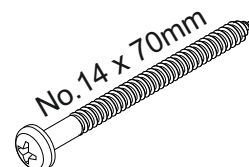

M - x2
Screw

Included Tools

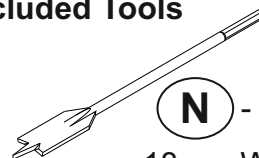

N - x1
18mm Wood
Drill



O - x1
3mm Hex
Key

2 Tools Required

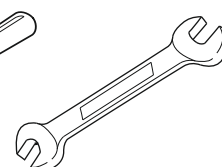
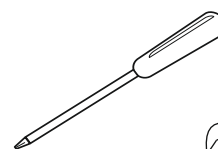
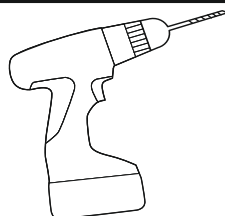
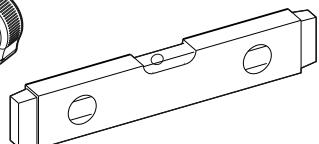
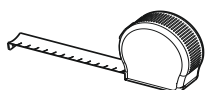

3 Determine Correct TV Screw Size

Choose from the TV Fixings selection. You need to determine which length and diameter of screws fits your TV. To determine the correct screw diameter, try screwing (F₂), (F₇), (F₁₁) & (F₁₅) into one of the fixing holes on the back of the screen until you find the one that fits. Note the thread size and ensure you use the appropriate diameter screws.

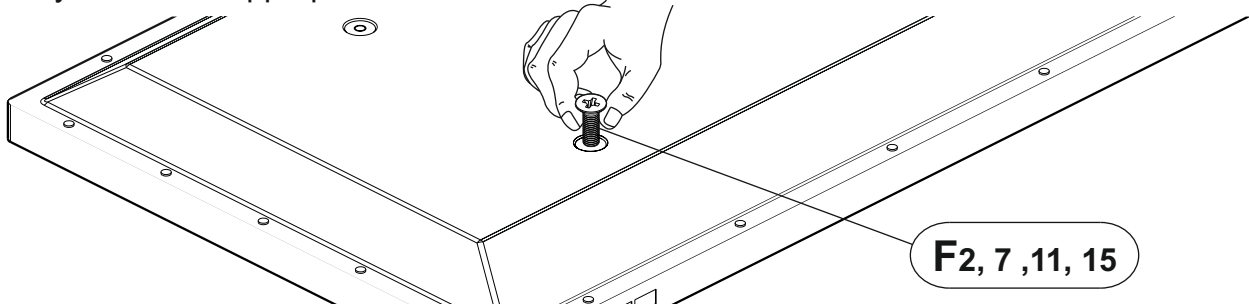

4 Fit Screen Hangers To TV

Once you have established which screws you need for your TV you can attach the Hanger (B) and Stand-offs (C) to the back of your TV.

Typical recommended examples shown are for fixings with the TV spaced 20mm from the wall. The TV Mount can position your TV between 20mm and 40mm from the wall. For alternative configurations see sections 9.

You might need to use spacers to increase the clearance of your TV from the wall in order to avoid cables coming out of your TV and improve access and ventilation to the back of your TV (spacers (D₁) allow you to have a gap of 30mm or 40mm, see section 9).

In certain circumstances it may be necessary to use red spacer (D₂) as either a replacement or addition to spacer (D₁). For more information please see section 9.

If your TV fixing centres don't fit, STOP installation and contact the customer services helpline.

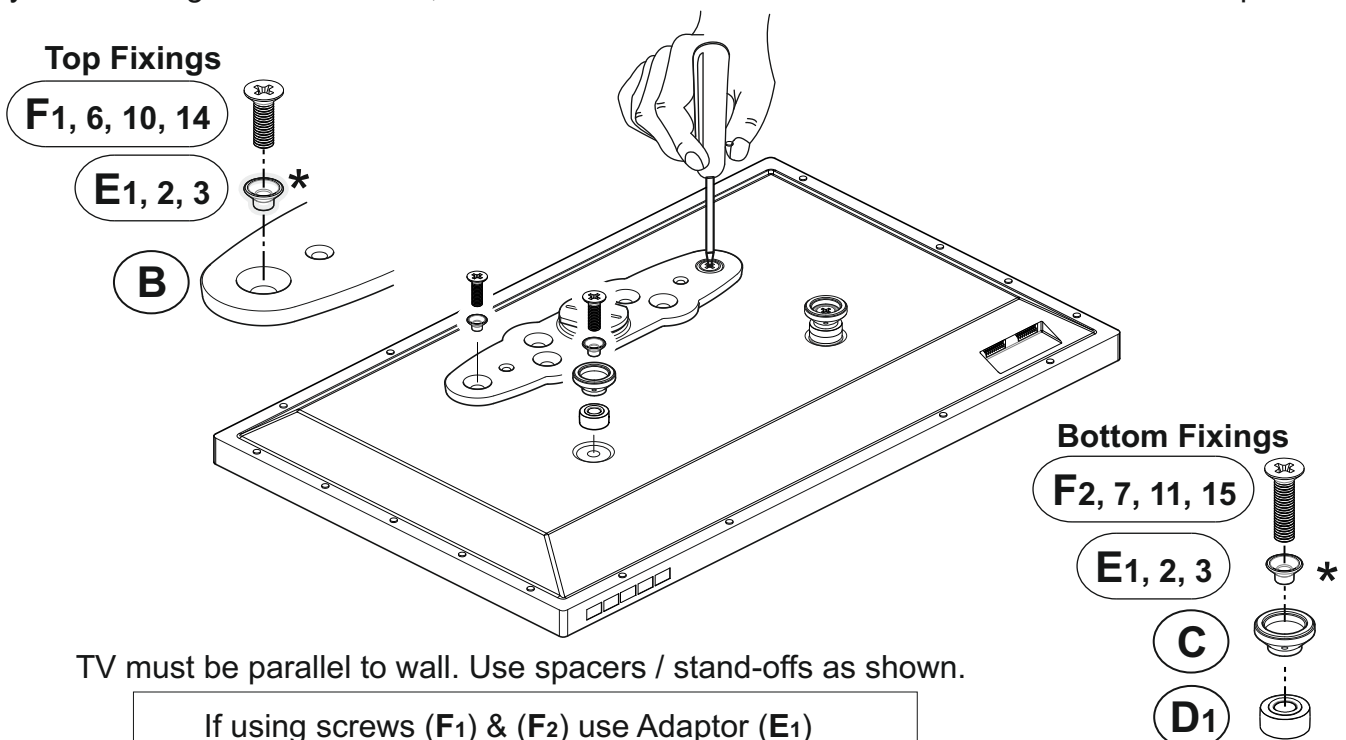

TV must be parallel to wall. Use spacers / stand-offs as shown.

- * If using screws (F₁) & (F₂) use Adaptor (E₁)
- * If using screws (F₆) & (F₇) use Adaptor (E₂)
- * If using screws (F₁₀) & (F₁₁) use Adaptor (E₃)
- * If using screws (F₁₄) & (F₁₅) no Adaptor required

5 Marking Wall For Drill Points



IMPORTANT:- When deciding where to locate your TV, remember clearance around your TV is required in order to fit the TV. See Section 8 "Hanging The TV".

Decide the position of your wall bracket and using a pencil lightly draw a straight, level line approx 220mm long.

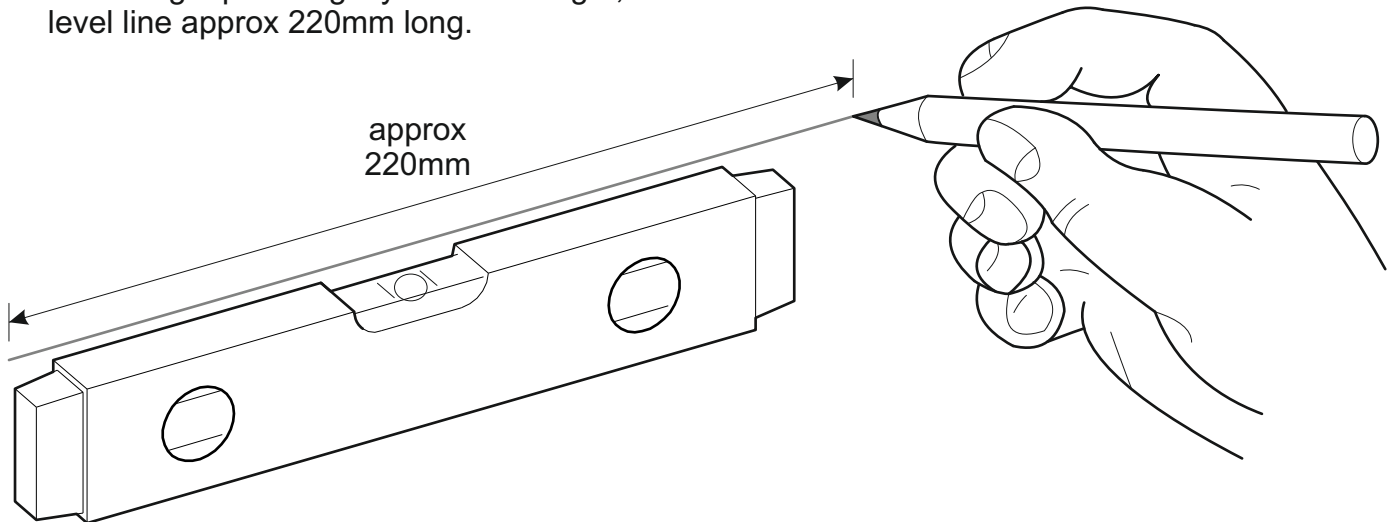

Use the Wall Bracket (A) as a template and position it on your wall. Ensure the bracket lines up with the line you have previously drawn and mark the two DRILL POINTS with a pencil.

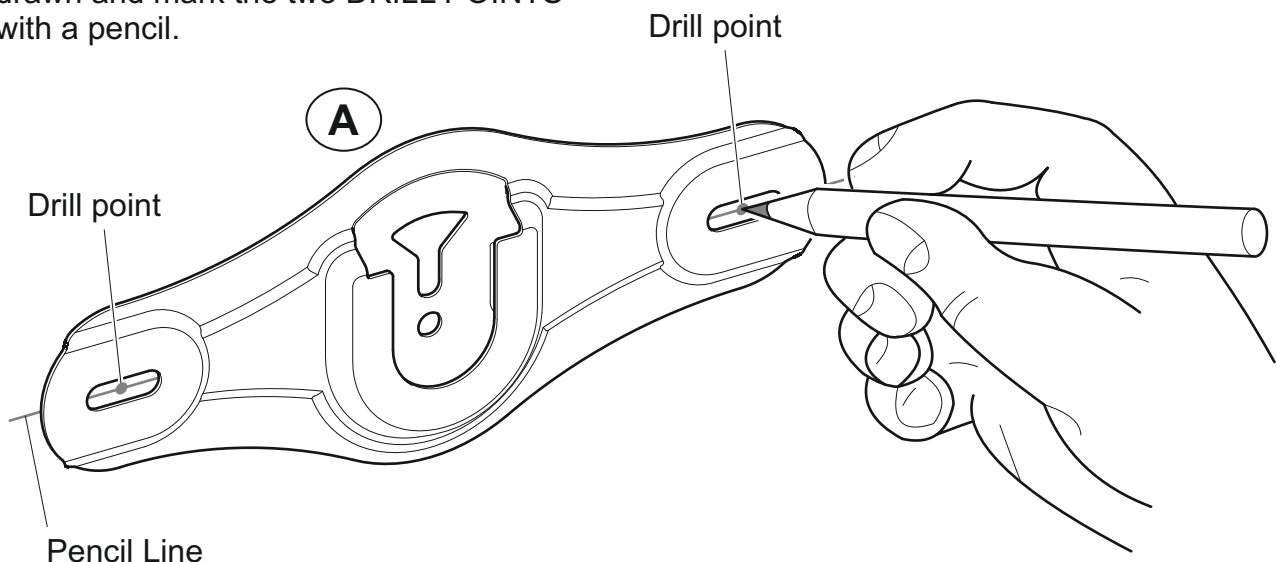

6 Planning & Preparation

Determine the wall type that you have (i.e. Brick/Stud/Plasterboard/Sheetrock).
Ensure the drilling area is free from mains services (Gas/Electric/Water).
Drill three 3mm diameter pilot holes to verify the wall type and select the appropriate fixings (See Section 7).

7 Install Wall Fixings

Use the correct fixings for your wall type. Mixing fixing types may be required for installations that span different wall types. **DO NOT OVER TIGHTEN SCREWS.**

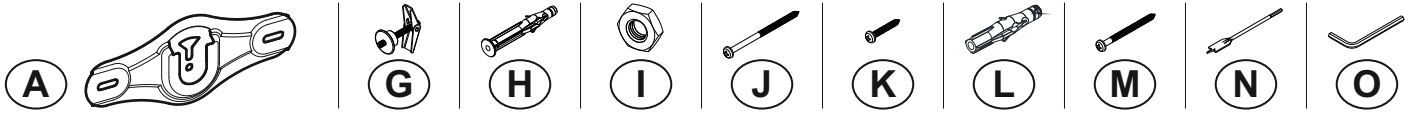

Solid Wall

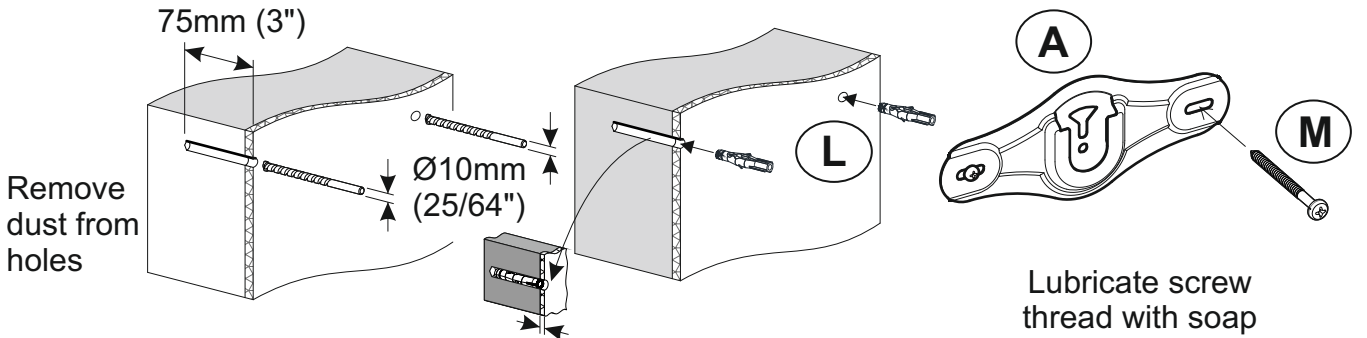

Dot & Dab

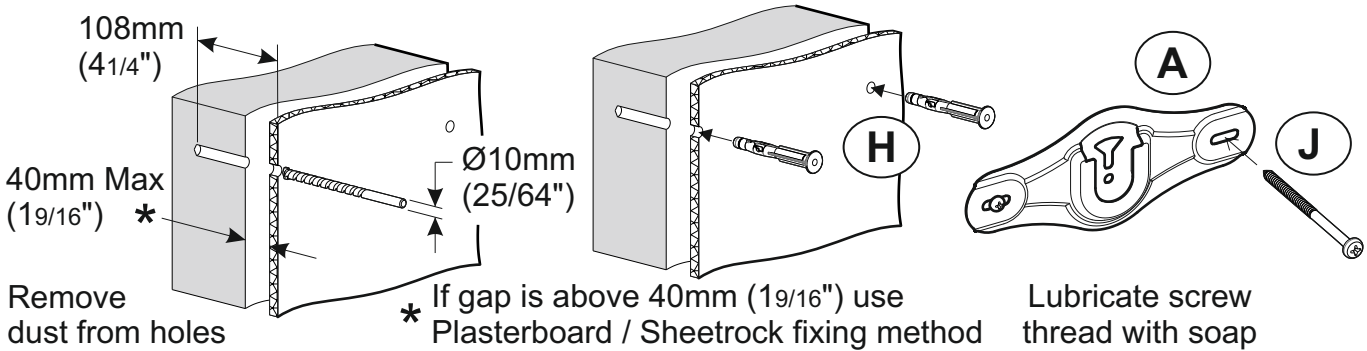

Plasterboard / Sheetrock

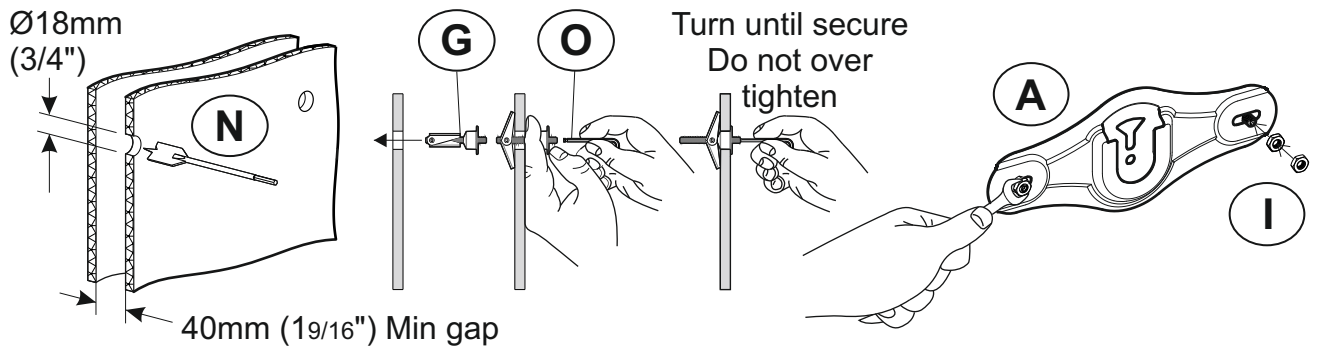

Wood Stud

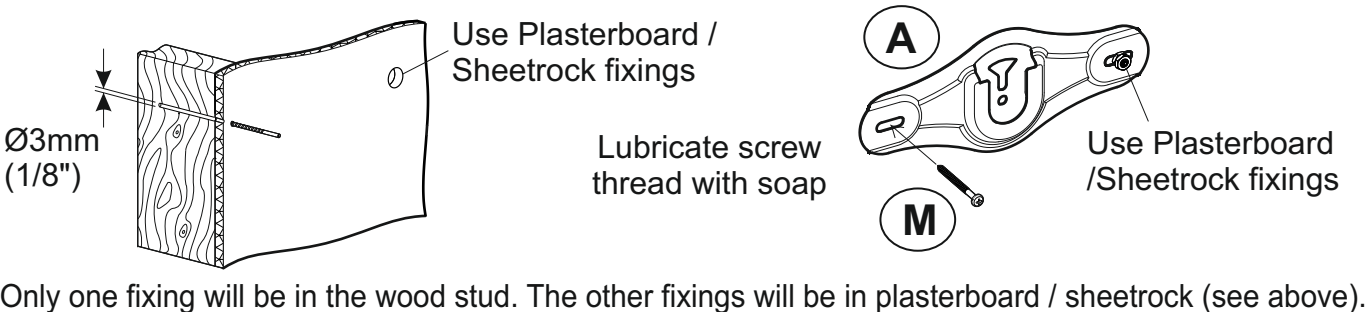

Metal Stud

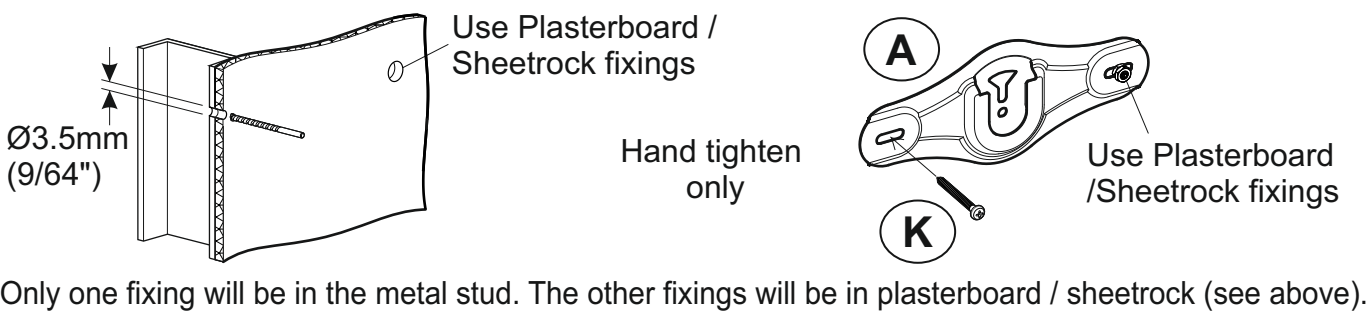

8 Hanging The TV

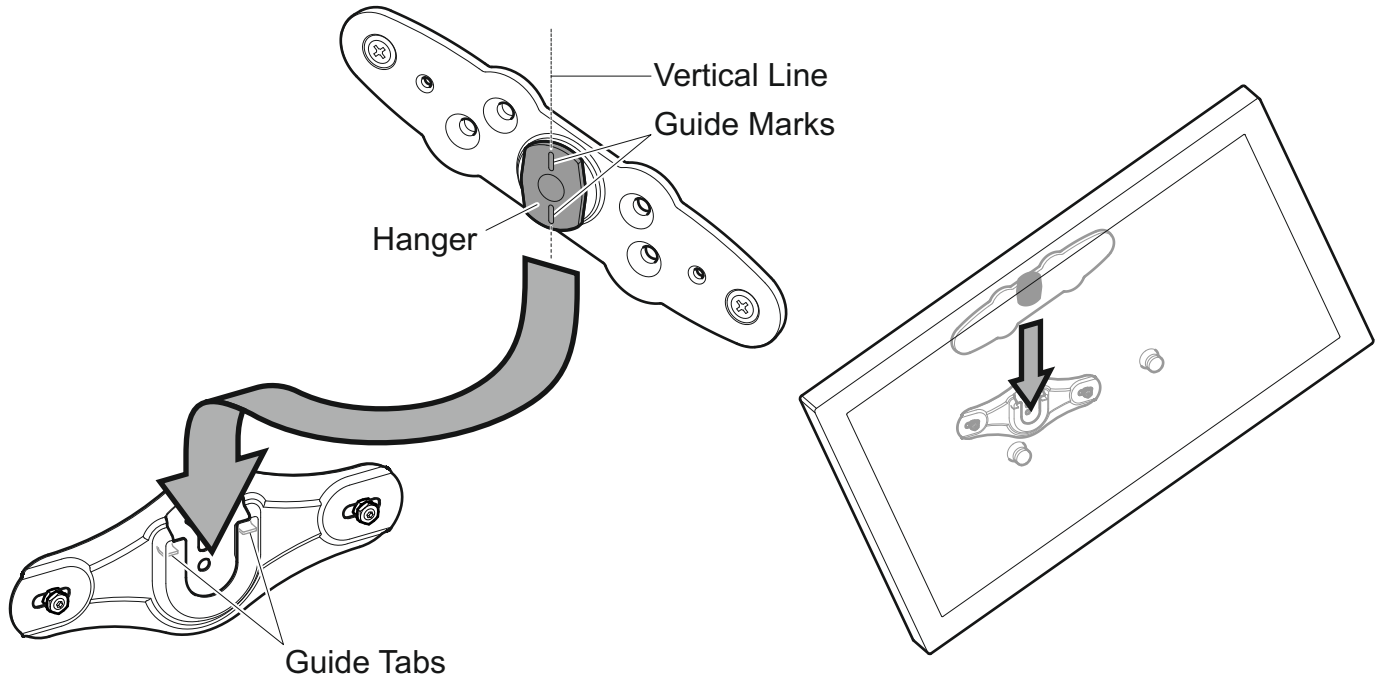

Rotate your TV so that the guide marks on the hanger are vertical. Next slide your TV down so that the hanger goes between the two guide tabs on the wall bracket. Ensure the hanger is fully engaged and rotate clockwise until your TV is level.

If cables from your TV prevent the TV resting against the wall then an alternative hanger configuration will be required (See Section 9).

TV must be parallel to wall. Use spacers / stand-offs as shown.

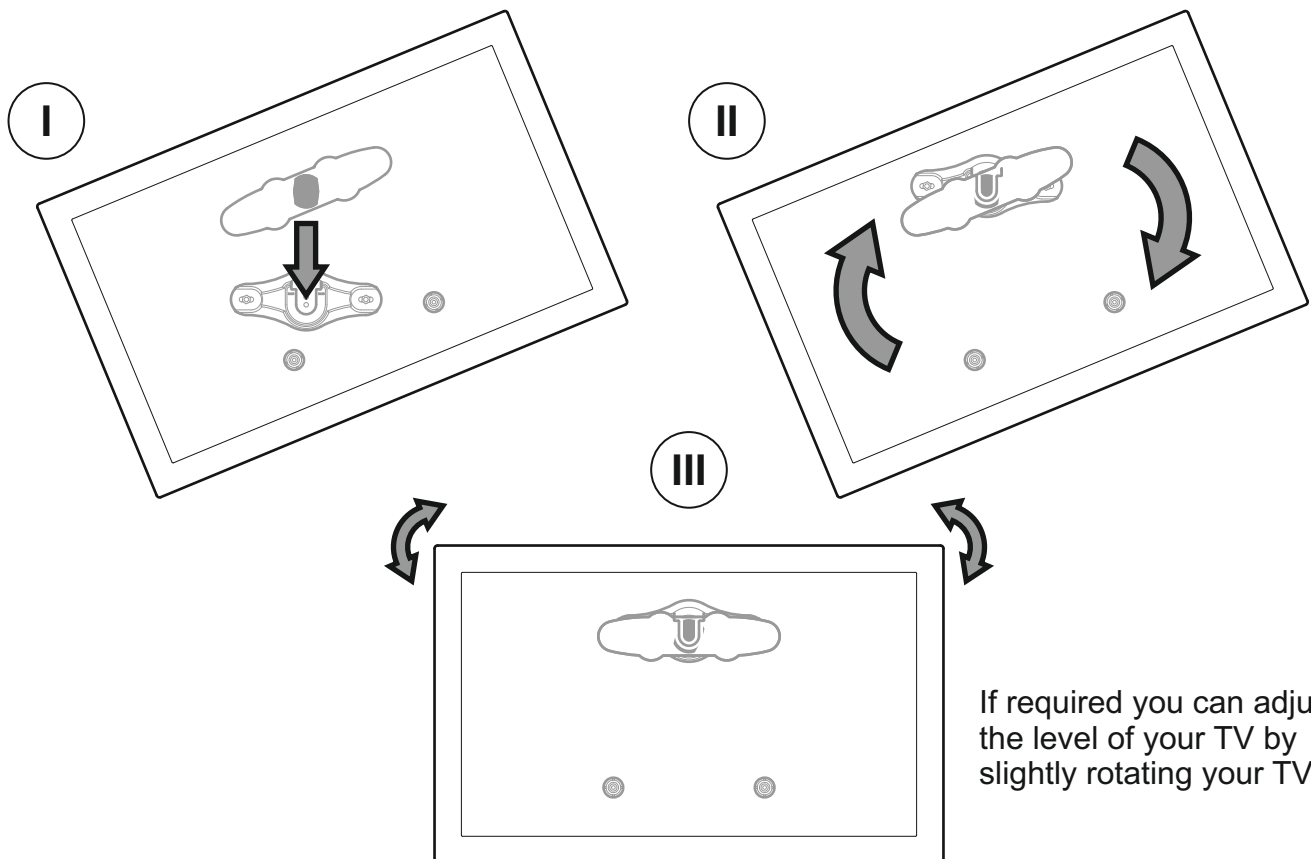

If required you can adjust the level of your TV by slightly rotating your TV.

Removing the TV

This is a two person job. To remove the TV rotate anti-clockwise between 15-30° and lift TV up and out (ie reverse the movements as shown above).

9 Alternative Hanger Configurations

Alternative Wall spacings of 20mm, 30mm & 40mm can be achieved using the spacer / screw combinations listed in this section.

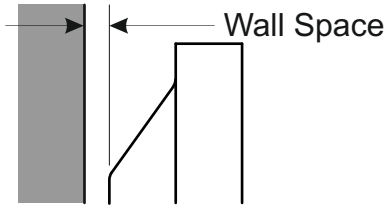

20mm Wall Space
(as shown in section 4)

Top Fixings



F1, 6, 10, 14



E1, 2, 3

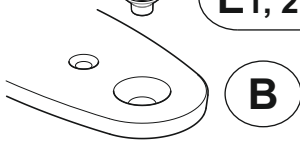

B

Bottom Fixings



F2, 7, 11, 15



E1, 2, 3



C



D1

30mm Wall Space

Top Fixings



F2, 7, 11, 15



E1, 2, 3

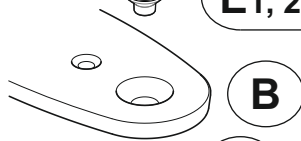

B

D1

Bottom Fixings



F3, 8, 12, 16



E1, 2, 3



C



D1



D1

40mm Wall Space

Top Fixings



F3, 8, 12, 16



E1, 2, 3

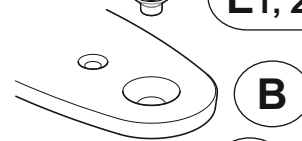

B

D1



D1

Bottom Fixings



F4, 9, 13, 17



E1, 2, 3



C



D1



D1



D1

TV must be parallel to wall. Use spacers / stand-offs as shown.

- Use adaptor (E₁) with screws (F₁), (F₂), (F₃), (F₄) & (F₅)
- Use adaptor (E₂) with screws (F₆), (F₇), (F₈) & (F₉)
- * Use adaptor (E₃) with screws (F₁₀), (F₁₁), (F₁₂) & (F₁₃)
- No adaptor required with screws (F₁₄), (F₁₅), (F₁₆) & (F₁₇)



When is it necessary to use red spacers?



D2 - x4

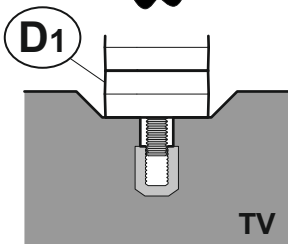

Problem
Not enough
screw engagement

It is recommended that when fitting Hanger (B) and Stand-offs (C) to your TV you have at least 5-10mm of screw engagement. In certain circumstances you may need to use red spacers (D₂) as either a replacement, or together with spacers (D₁) to achieve this. Whenever you use red spacers (D₂) you must use all 4 provided.

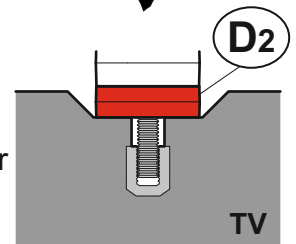

Solution
Red spacer (D₂) has
replaced spacer (D₁)

