

Instructions Instrucciones Instructions

464553 rev00

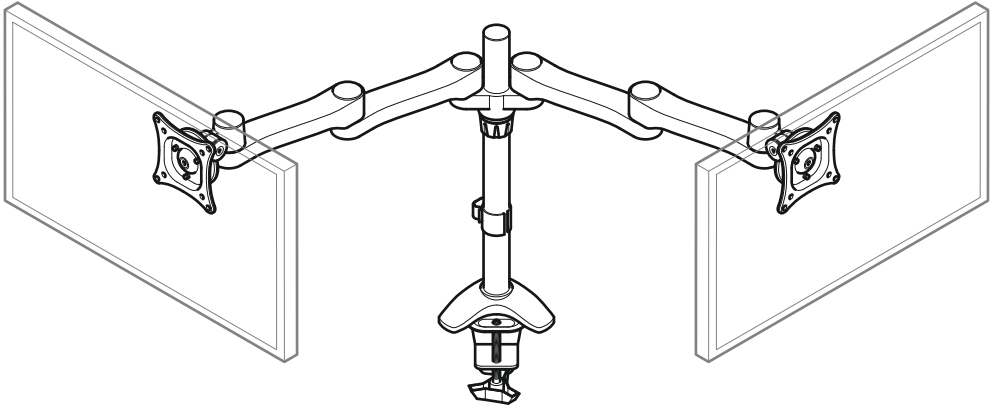

*Read through **ALL** instructions before commencing assembly.
If you have any questions about this product or issues with assembly contact the customer services help line before returning this product to the store.*



*Lea todas las instrucciones antes de empezar la instalación.
Si usted tiene alguna pregunta acerca de este producto o problemas con la instalación contacte los servicios de ayuda al cliente antes de devolver este producto a la tienda.*



*Lisez toutes les instructions avant de débiter l'installation.
Si vous avez des questions sur ce produit ou sur son installation, contactez le service d'assistance clientèle avant de renvoyer le produit au magasin.*

**CUSTOMER SERVICES HELP LINE NUMBER:
NUMERO DE SERVICIO DE ATENCION AL CLIENTE:
NUMÉRO DE L'ASSISTANCE CLIENT:**

**+44 (0)1952 670009 (UK)
1-800 667 0808 (USA)**



**Per Screen
Por cada pantalla
Par écran**

27"
68cm

AVF Group Ltd. Hortonwood 30, Telford, Shropshire, TF1 7YE, England
AVF Incorporated 3187, Cornerstone Drive, Eastvale, CA 91752, USA
www.avfgroup.com

Retain all packaging in case the bracket needs to be returned.

Contents may vary from photography/ Illustrations.

You will not need all these parts, so expect there to be some left over depending upon the specification of your projector.

This product is intended for indoor use only. Use of this product outdoors could lead to failure and personal injury.

It is the responsibility of the installer to ensure that the mounting surface is of a suitable standard and void of any services (eg gas, electricity, water etc).

AVF accept no responsibility for any damage or loss caused by installing this product on a sub standard surface.

Conserve todos los envasados en caso de que el soporte tenga que ser devuelto.

El contenido puede variar de la fotografía / ilustración.

No necesitará todas estas partes, espere que sobren algunas según las especificaciones de su proyector.

Este producto está diseñado para el uso en el interior solamente. El uso de este producto en el exterior podría llevar al fracaso y lesiones personales.

Es la responsabilidad del instalador de asegurarse de que la superficie de montaje es de un nivel adecuado y carece de todo los servicios (gas, electricidad, agua, etc.).

AVF no acepta ninguna responsabilidad por cualquier daño o pérdida causada por la instalación de este producto en una superficie inadecuada.

Conserver les emballages si l'applique a besoin d'être ramenée.

Les contenus peuvent varier de la photographie/illustrations.

Vous n'aurez pas besoin de toutes ces pièces, attendez-vous donc à ce qu'il reste des pièces selon les caractéristiques de votre projecteur..

Ce produit est à utiliser à l'intérieur uniquement. Utiliser ce produit à l'extérieur causera des défaillances et de possibles accidents..

Il est de la responsabilité de l'installateur de s'assurer que les surface soient aux critères requis et vides de tout câblage (ex : gaz, électricité, eau etc....)

AVF n'acceptera aucune responsabilité pour tout dommage ou perte causée par l'installation du produit dans un surface en deçà de ces critères.

Tools Recommended
Herramientas recomendadas
Outils recommandés

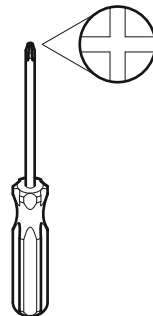
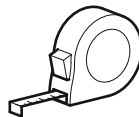
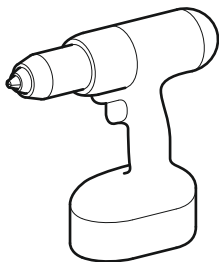

Ø12mm (1/2")
Wood
Madera
Bois

Boxed Parts
Piezas en la Caja
Pièces empaquetées

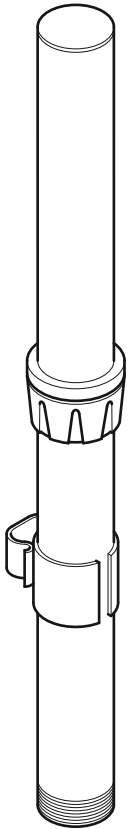

A x1

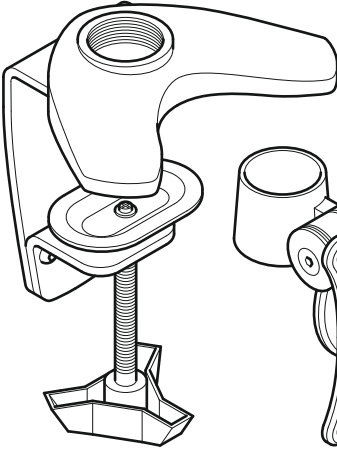

B x1

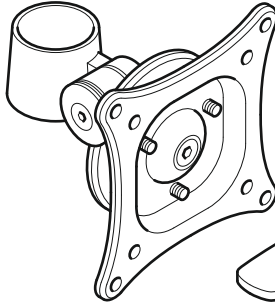

C x2



D x1



E x1



F x8



L x6

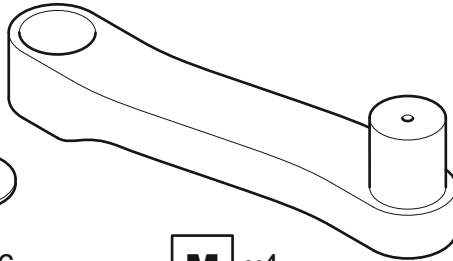

M x4

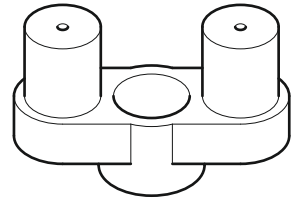

N x1

Monitor Screws
Tornillos del monitor
Vis de fixation de l'écran

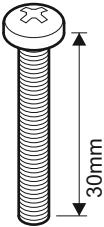

M4

G1 x8

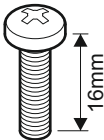

M4

G2 x8

30mm

16mm



H1 x8



H2 x8

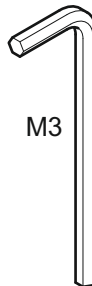

M3

I x1

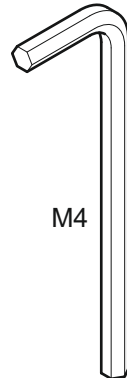

M4

J x1

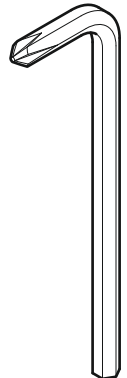

K x1

1

Measure the Monitor fixing holes
 Medir los orificios de fijación del monitor
 Mesurer les trous d'ancrage de l'écran

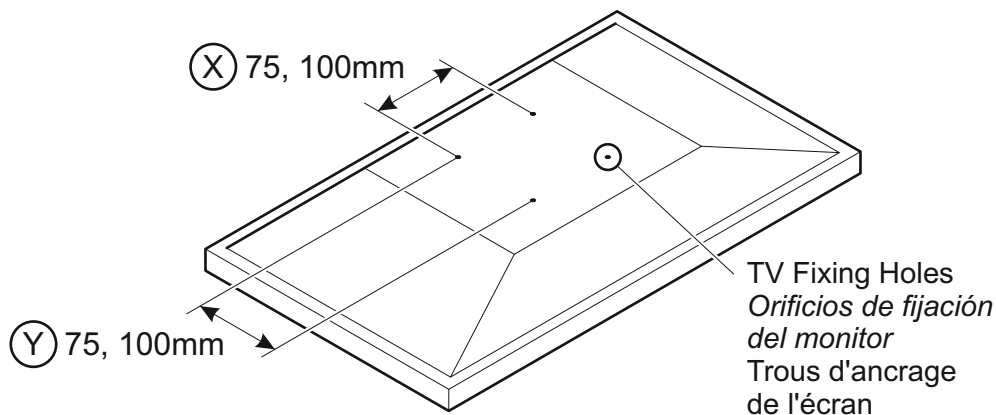

If width (X) is not equal to 75 or 100mm or height (Y) is not equal to 75 or 100mm STOP installation now and contact the customer help line

Si el ancho (X) no es igual a 75 o 100 mm, o si la altura (Y) no es igual a 75 o 100 mm DETENGA en este momento la instalación y póngase en contacto con la línea de asistencia al cliente

Si la largeur (X) n'est pas égale à 75 ou 100mm ou si la hauteur (Y) n'est pas égale à 75 ou 100mm, ARRÊTER immédiatement l'installation et communiquez avec le service d'assistance à la clientèle

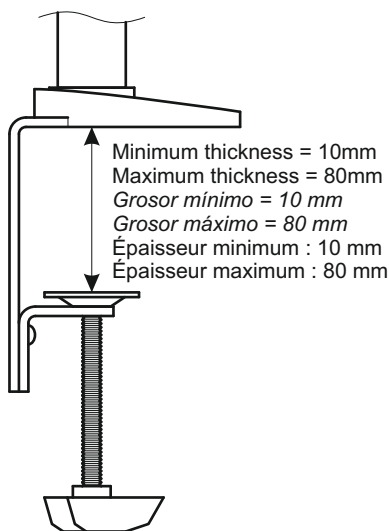

If mounting material is less than 10mm or more than 80mm STOP installation now and contact the customer help line

Si el material de montaje es menor a 10 mm o más de 80 mm, DETENGA la instalación y contacte a la línea de ayuda de atención al cliente

Si l'épaisseur du matériel de fixation est inférieure à 10 mm ou supérieure à 80 mm, CESSEZ l'installation immédiatement et communiquez avec le soutien technique

2

Column assembly
 Columna de ensamblaje
 Assemblage du bras de fixation

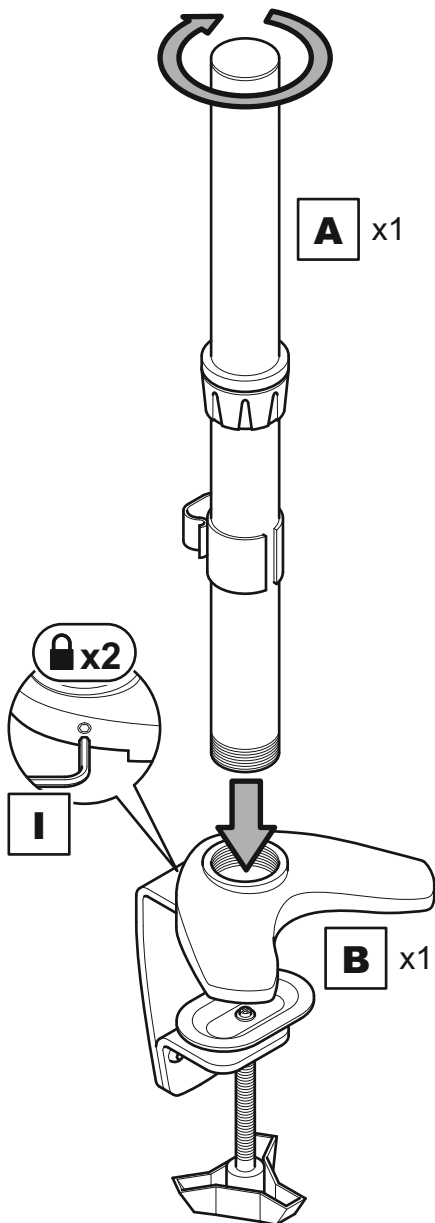

Do not over tighten
 No apriete demasiado
 Ne serrez pas trop fort

**3**

Installation Method
 Método de instalación
 Méthode d'installation

You can install the mount in 2 ways
 Puede instalar el soporte de 2 maneras
 Il existe deux méthodes possibles de fixation murale

Clamp Method
 Método con abrazaderas
 Méthode par bloc d'attache

or / o / ou

Hole Method
 Método con orificios
 Méthode par trous d'ancrage

Decide what installation method you require and follow the appropriate steps
 Decida qué método de instalación requiere y siga los pasos apropiados
 Décider de la méthode de montage souhaitée et suivre les instructions appropriées

Clamp Method
 Método con abrazaderas
 Méthode par bloc d'attache

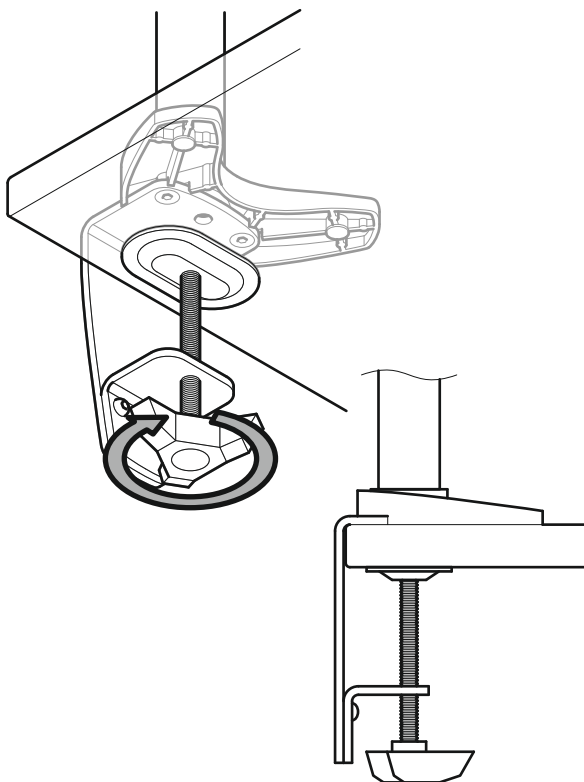

Hole Method
Método con orificios
Méthode par trous d'ancrage

i

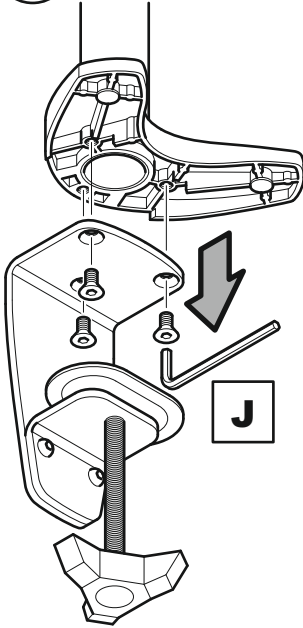

ii

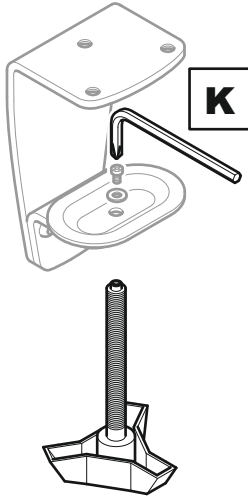

iii

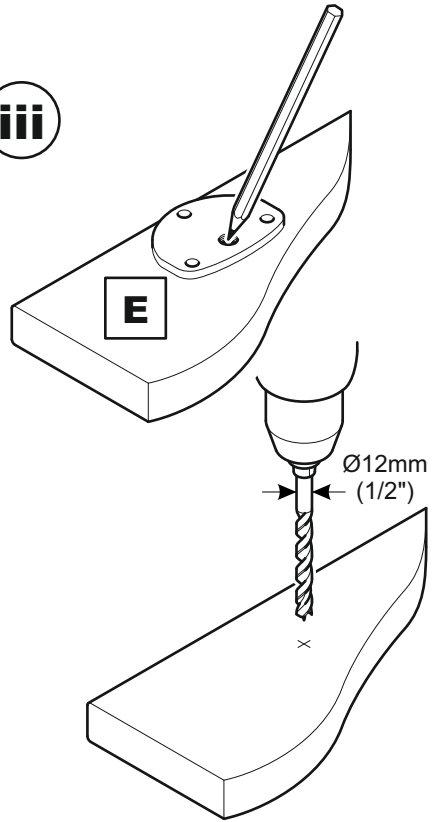

Remove and keep
Retire y mantenga
Retirer et conserver

iv

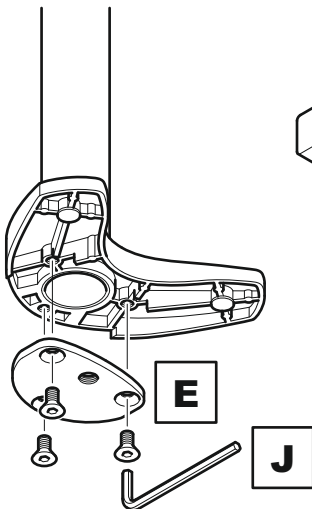

v

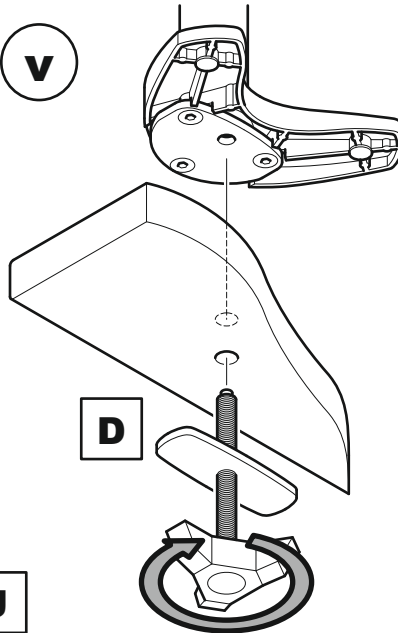

vi

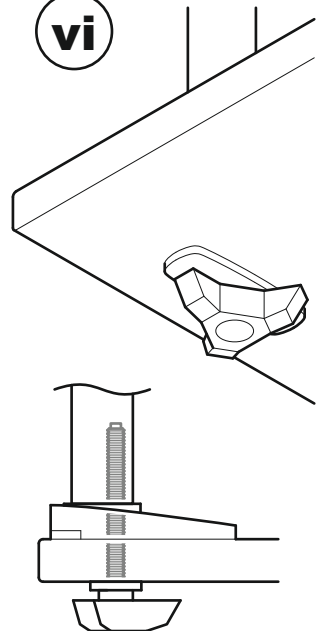

4

Fitting the Monitor Mounting Bracket Ajuste el monitor al soporte de montaje Installation du support de montage de l'écran

No Spacers
Sin espaciadores
Pas de séparateur

For Monitors with flat/
unobstructed back
Para monitores con el dorso
plano / sin obstrucciones
Pour des écrans à arrière plat
et dégagé

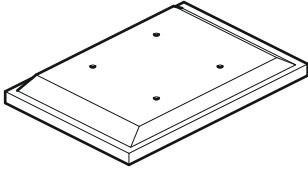

Spacers
Espaciadores
Séparateurs

H1/H2

For Monitors with irregular/obstructed back
Para monitores con dorso irregular / obstrucciones
Pour des écrans à arrière irrégulier et non dégagé

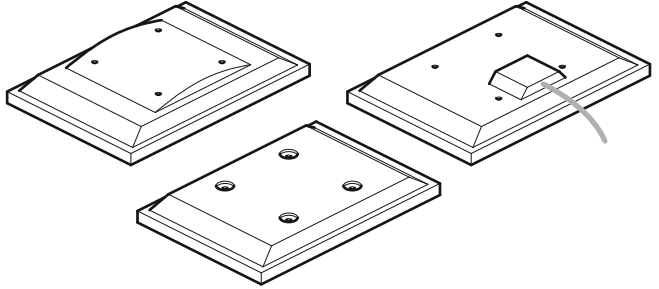

WARNING / ADVERTENCIA / AVERTISSEMENT

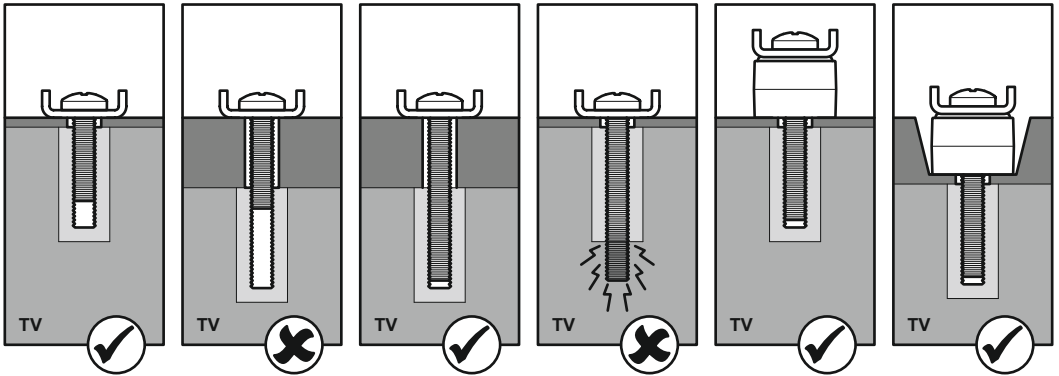

You can install the monitor in 2 ways
Puede instalar el monitor de 2 maneras
Il existe deux façons possibles
d'installer l'écran

Landscape
Paisaje
En position horizontale

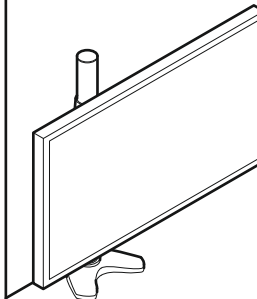

or
ou

Portrait
Retrato
En position
verticale

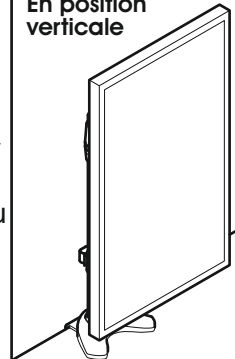

Decide what installation
method you require and
follow the appropriate steps
Decida qué método de
instalación requiere y siga
los pasos apropiados
Décider de la méthode de
montage souhaitée et suivre
les instructions appropriées

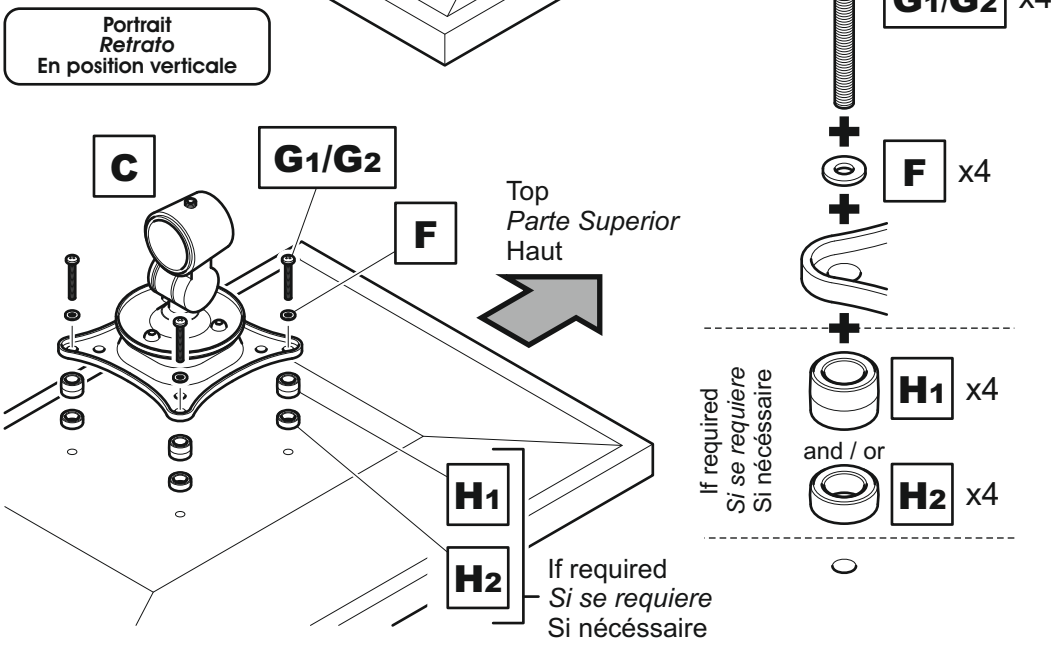
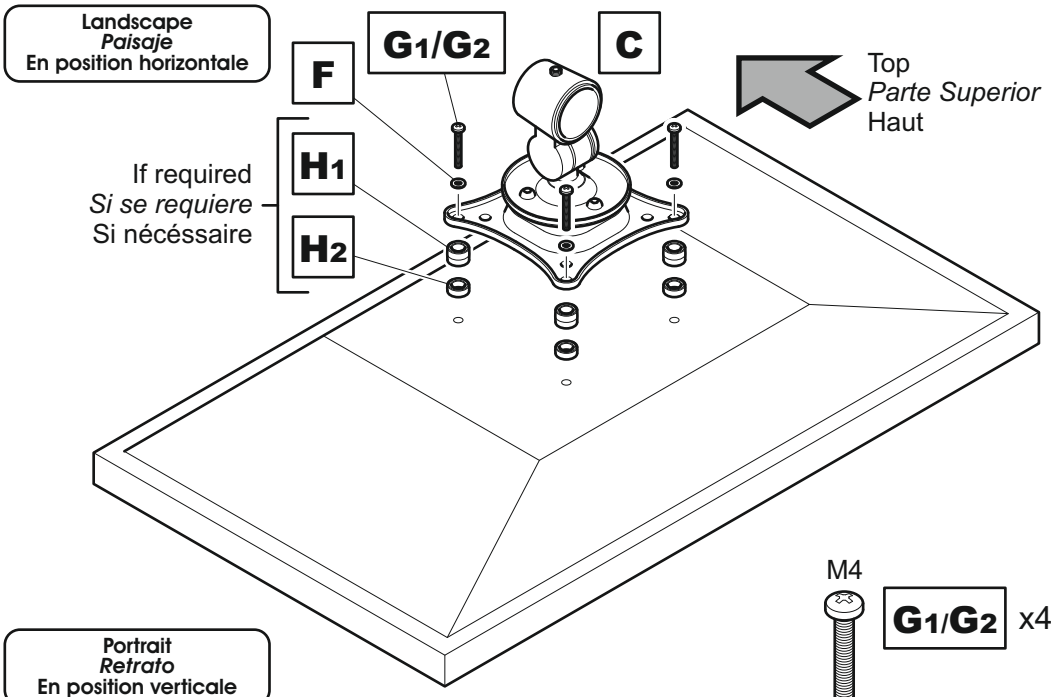

Attach the bracket to your Monitor using suitable screw, reducer and spacer combinations
Fije el soporte al monitor usando el tornillo adecuado, combine reducciones y espaciamento
 Fixez le support à votre écran en utilisant des combinaisons appropriées de vis, de réducteur et d'entretoise.



After completing step 4 you will have fittings left over, please keep for future reference
Después de completar el paso 4 usted tendrá conexiones sobrantes, por favor guarde para futura referencia.
 Après avoir complété l'étape 4 il vous restera des pièces d'assemblage, conservez-les

5

Setting Height Ajuste la altura Déterminer la hauteur

Before fixing height consider the size of your monitor

Antes de ajustar la altura tenga en cuenta el tamaño de su monitor

Veillez prendre en considération la taille de l'écran avant de déterminer la hauteur à laquelle il sera installé



Unlock
Desbloquear
Déverrouiller

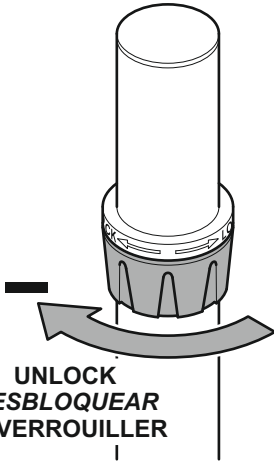

Set height
Ajustar altura
Déterminer la hauteur

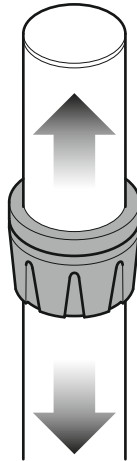

Lock
Bloquear
Verrouiller

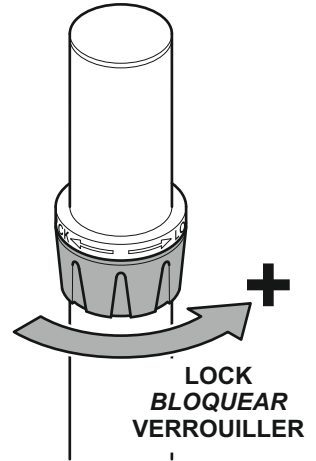

6

Attaching Monitor Colocación del monitor Fixer l'écran

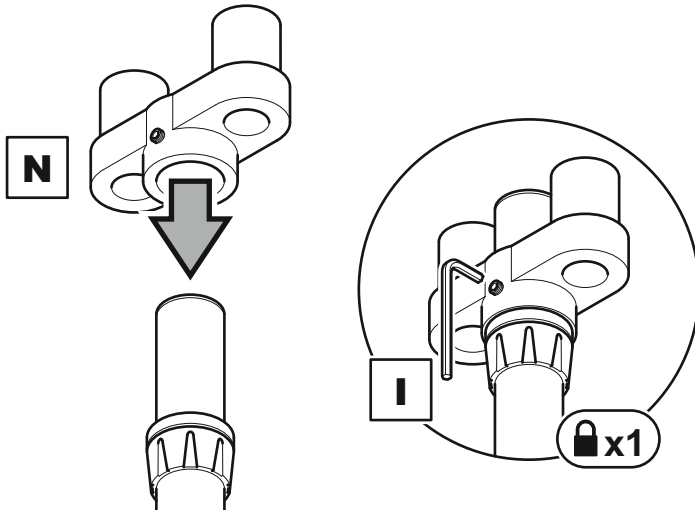

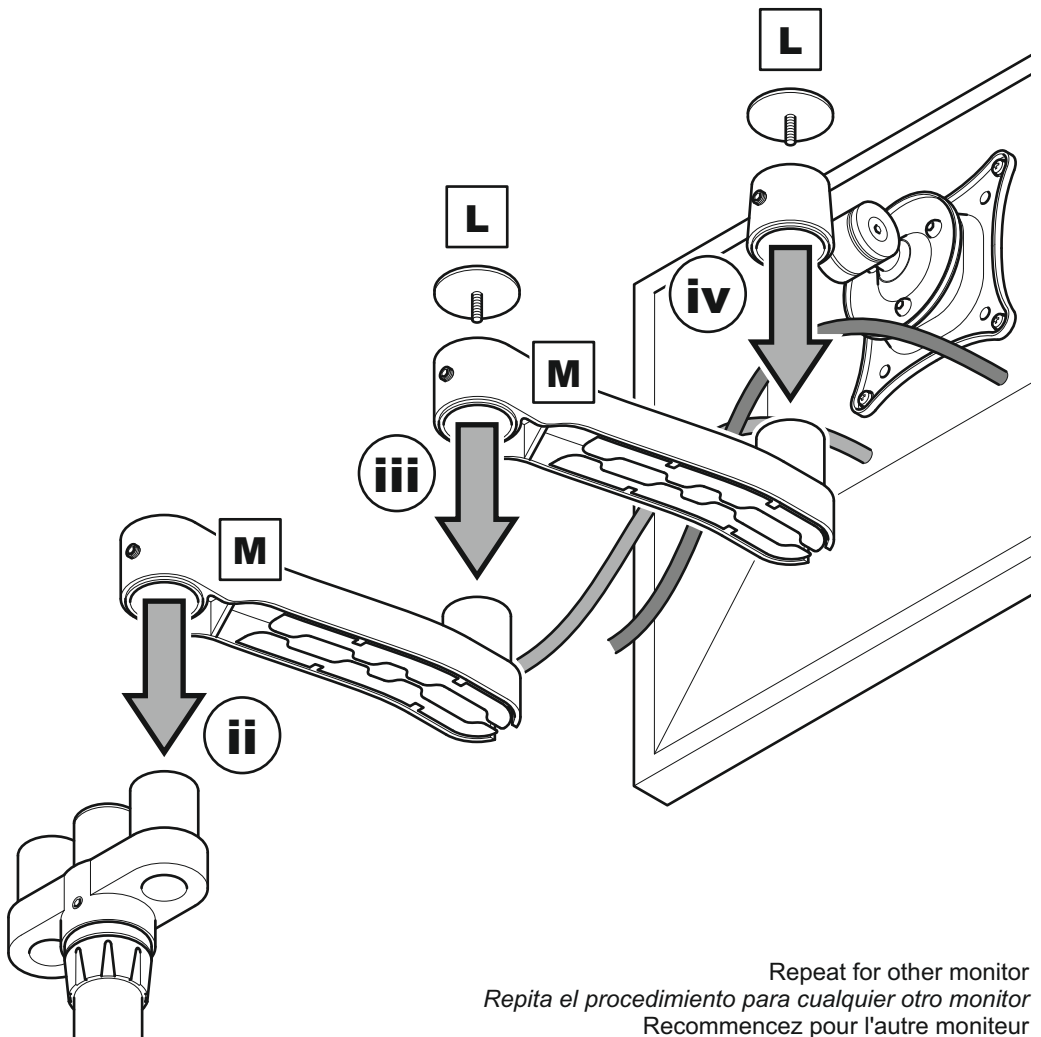
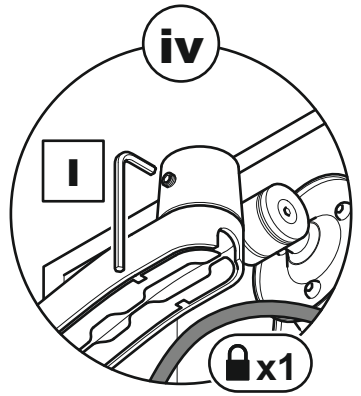
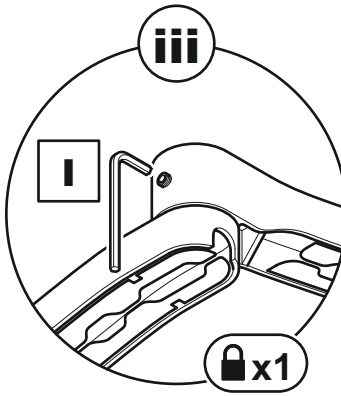
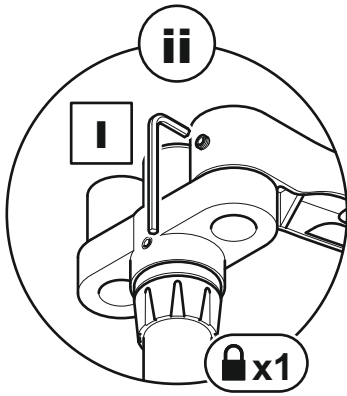

Repeat for other monitor
 Repita el procedimiento para cualquier otro monitor
 Recommencez pour l'autre moniteur

7

Cable Management Cache-câbles Manejo de Cable



Ensure cables don't restrict movement
Assurez-vous que les câbles ne limitent pas les mouvements
Asegúrese de que los cables no restrinjan el movimiento

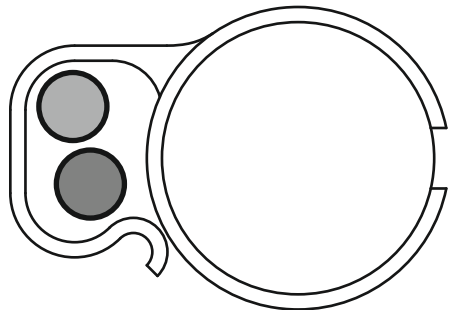
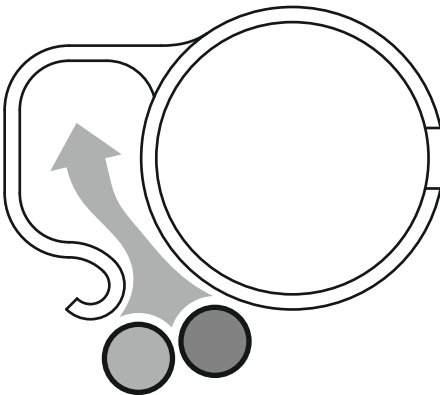
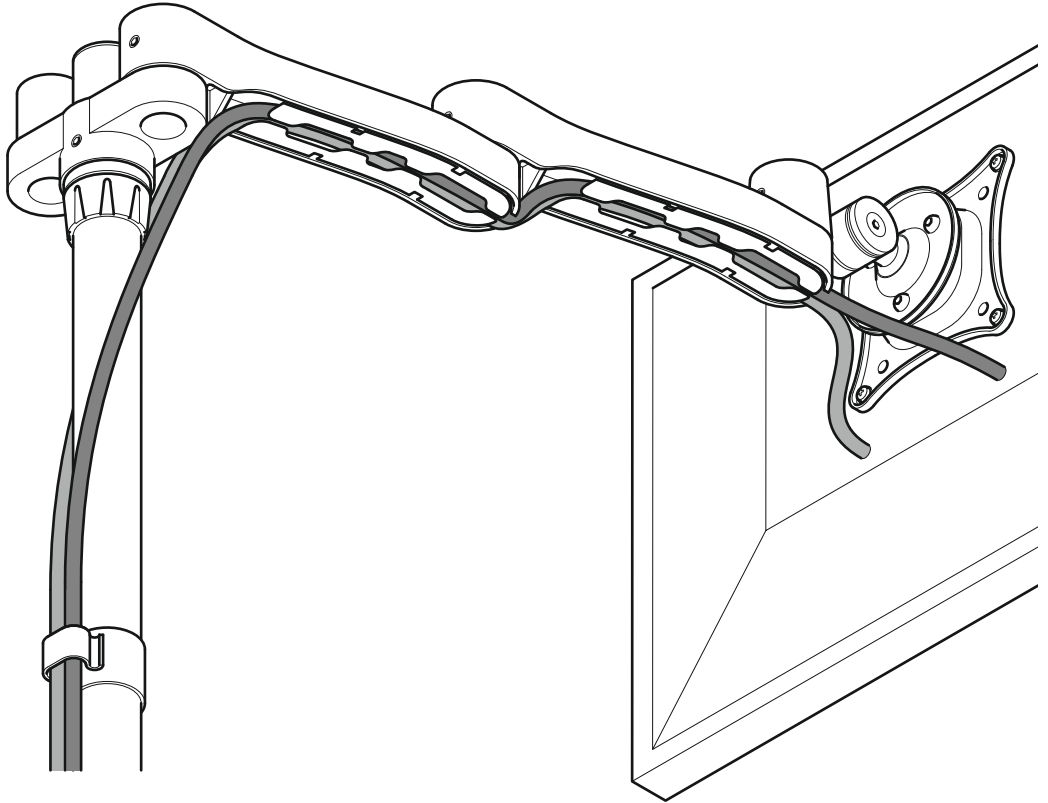

Repeat for other monitor
Repita el procedimiento para cualquier otro monitor
Recommencez pour l'autre moniteur

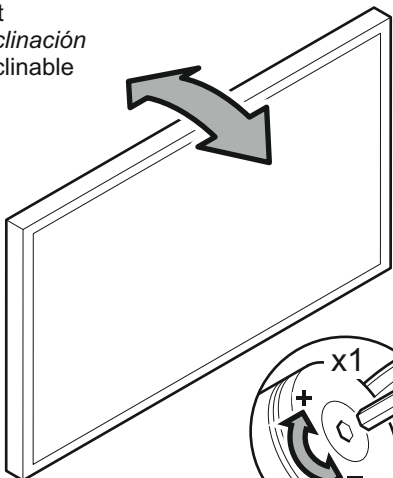
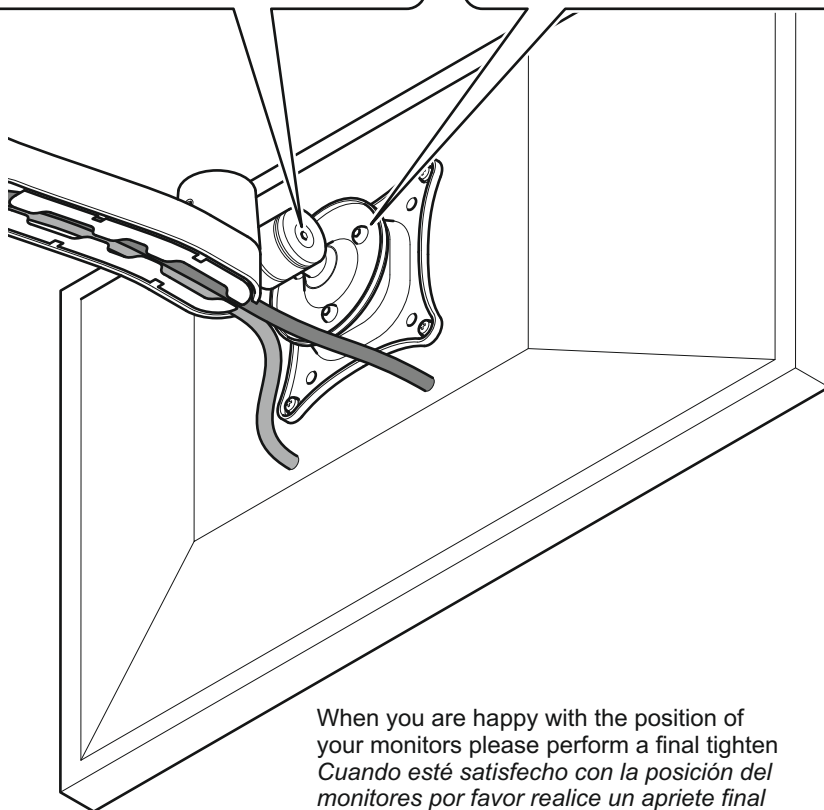
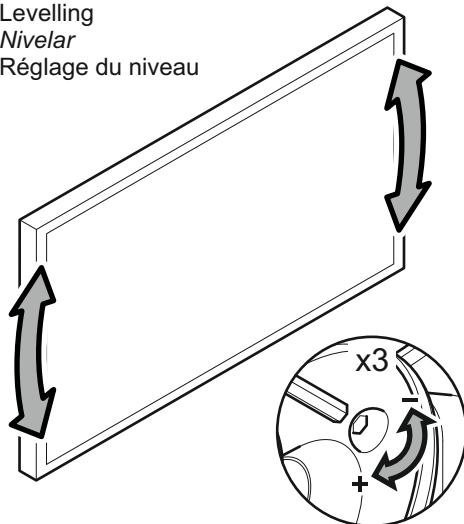
8**Optional
Optionnel
Opcional****Tilt**
Inclinación
Inclinable**Levelling**
Nivelar
Réglage du niveau

M4

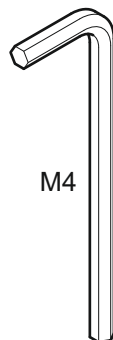

When you are happy with the position of your monitors please perform a final tighten
Cuando esté satisfecho con la posición de los monitores por favor realice un apriete final
Lorsque vous êtes satisfait de la position de vos moniteurs, veuillez effectuer un dernier serrage

J

x1