

1 Prepare the Joint and Base  
Prepara las juntas y la base

Optional  
Opcional

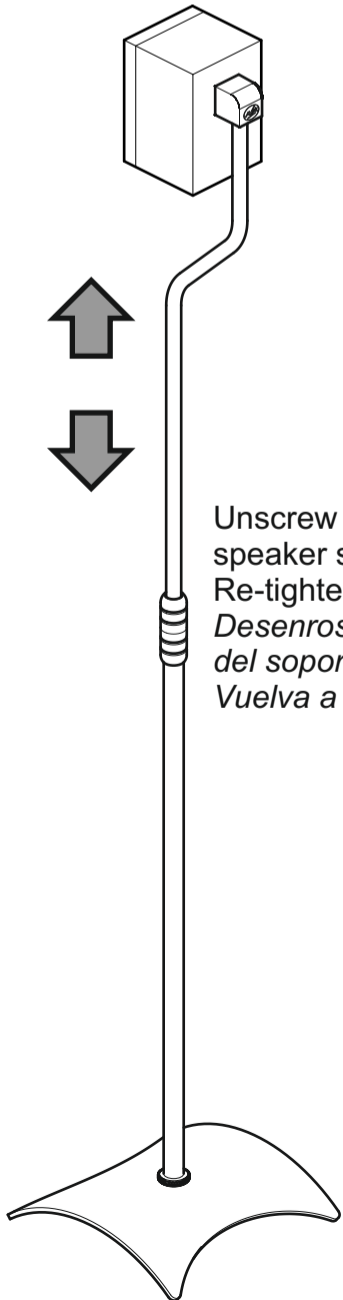

Unscrew joint to adjust the height of the speaker stand.  
Re-tighten after adjustment.  
Desenrosque la junta para ajustar la altura del soporte del altavoz  
Vuelva a apretar después del ajuste

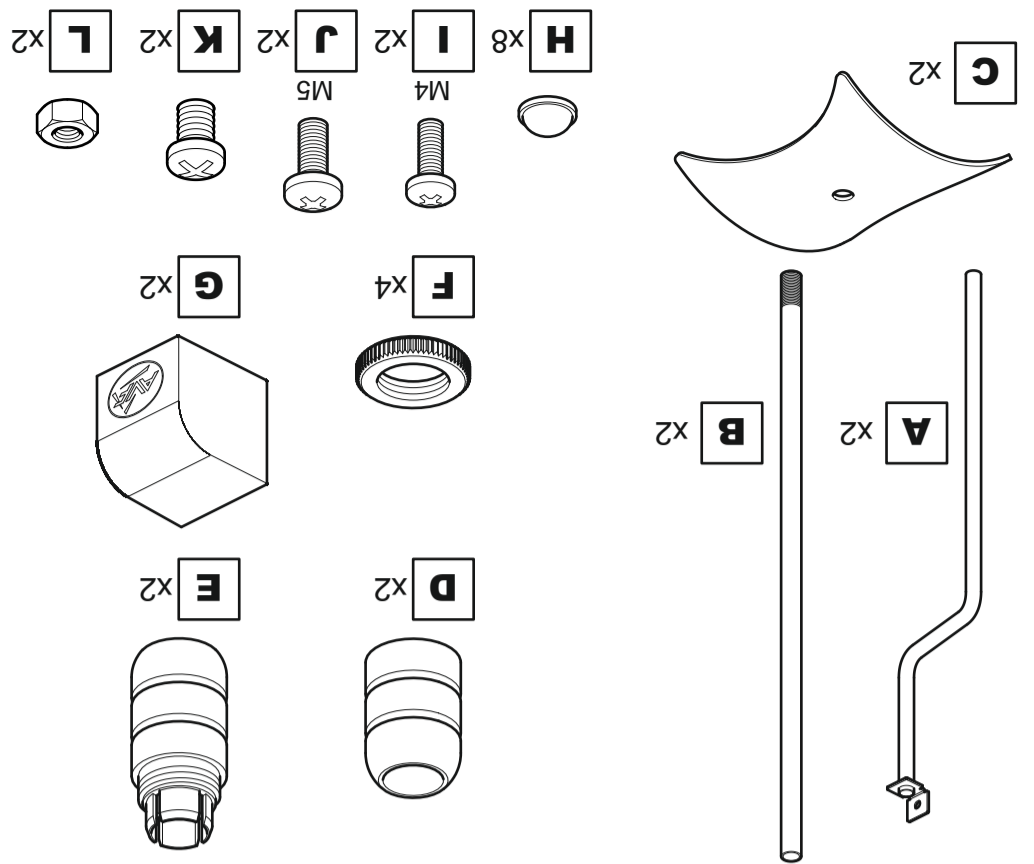

Boxed Parts  
Piezas en la Caja

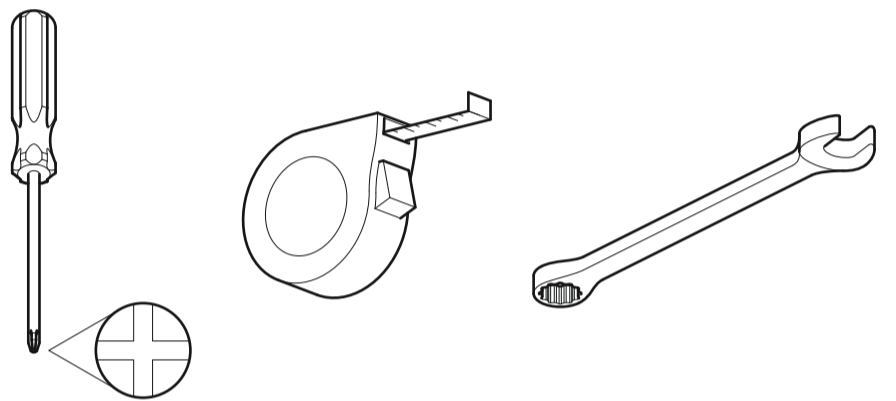

Tools Recommended  
Herramientas recomendadas

**EAK80-E**

English language / Idioma Español

Leaflet No. / No. de folleto 464340 rev 00

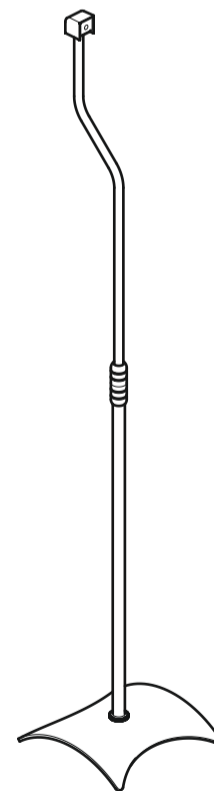

Read through **ALL** instructions before commencing installation.  
If you have any questions about this product or issues with installation contact the customer services help line before returning this product to the store.



Lea todas las instrucciones antes de empezar la instalación.  
Si usted tiene alguna pregunta acerca de este producto o problemas con la instalación contacte los servicios de ayuda al cliente antes de devolver este producto a la tienda.

CUSTOMER SERVICES HELP LINE NUMBER:  
NUMERO DE SERVICIO DE ATENCION AL CLIENTE:  
**1-800 601 8450 (USA)**



**2** Prepare the Speaker Stands  
Prepara los soportes del altavoz

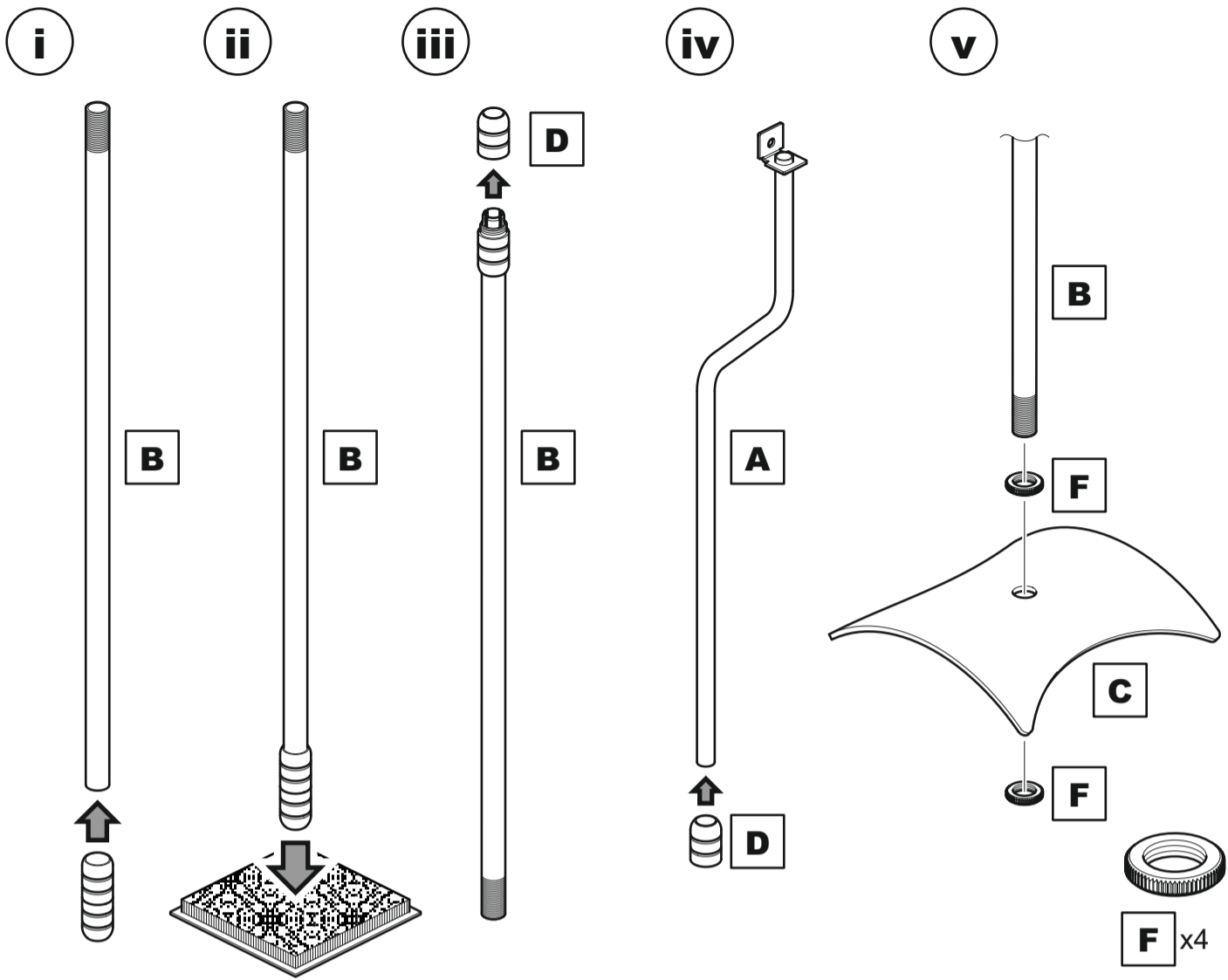

Place assembled joint onto the end of tube **B** and knock firmly on the carpet until fully seated.  
Coloque la junta en el extremo del tubo **B** y golpee firmemente en la alfombra hasta que esté completamente asentada

**3** Connect the Tubes  
Conecte los tubos

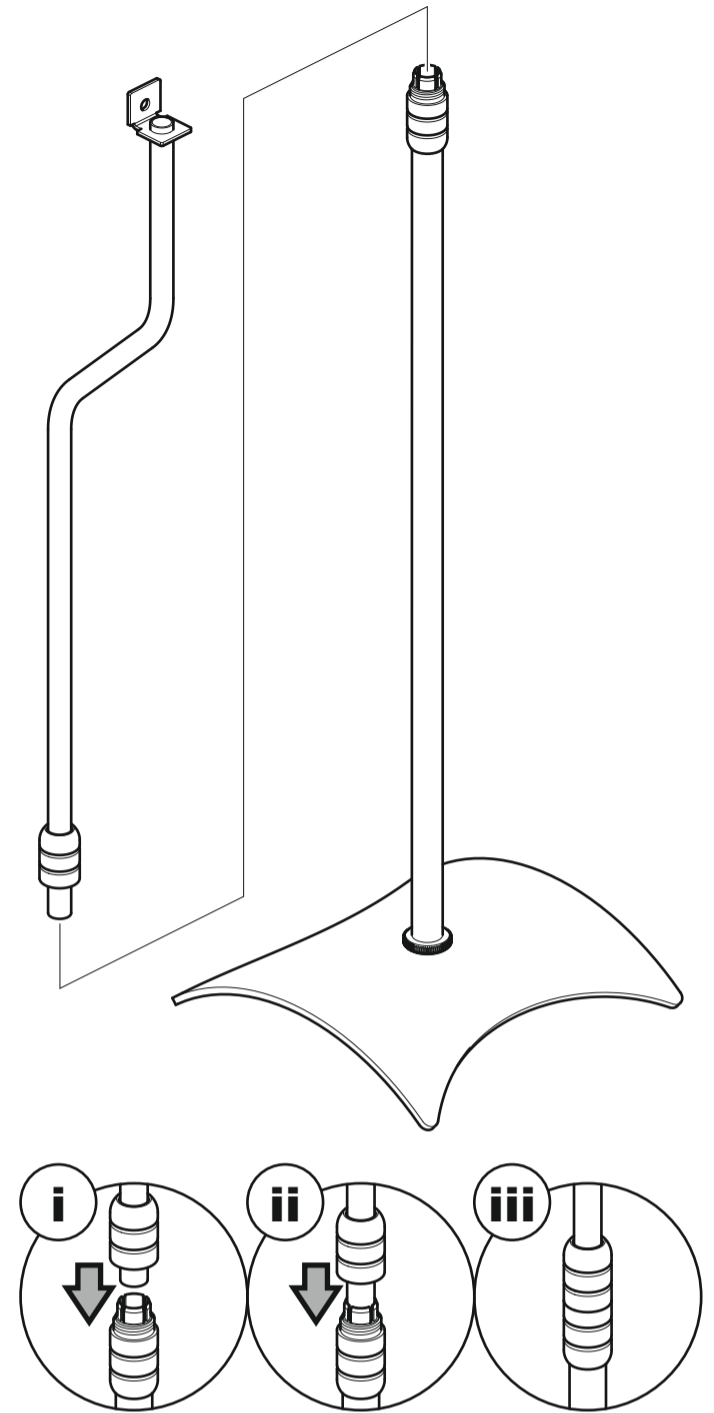

**4** Cable Management  
Sistema guardacables

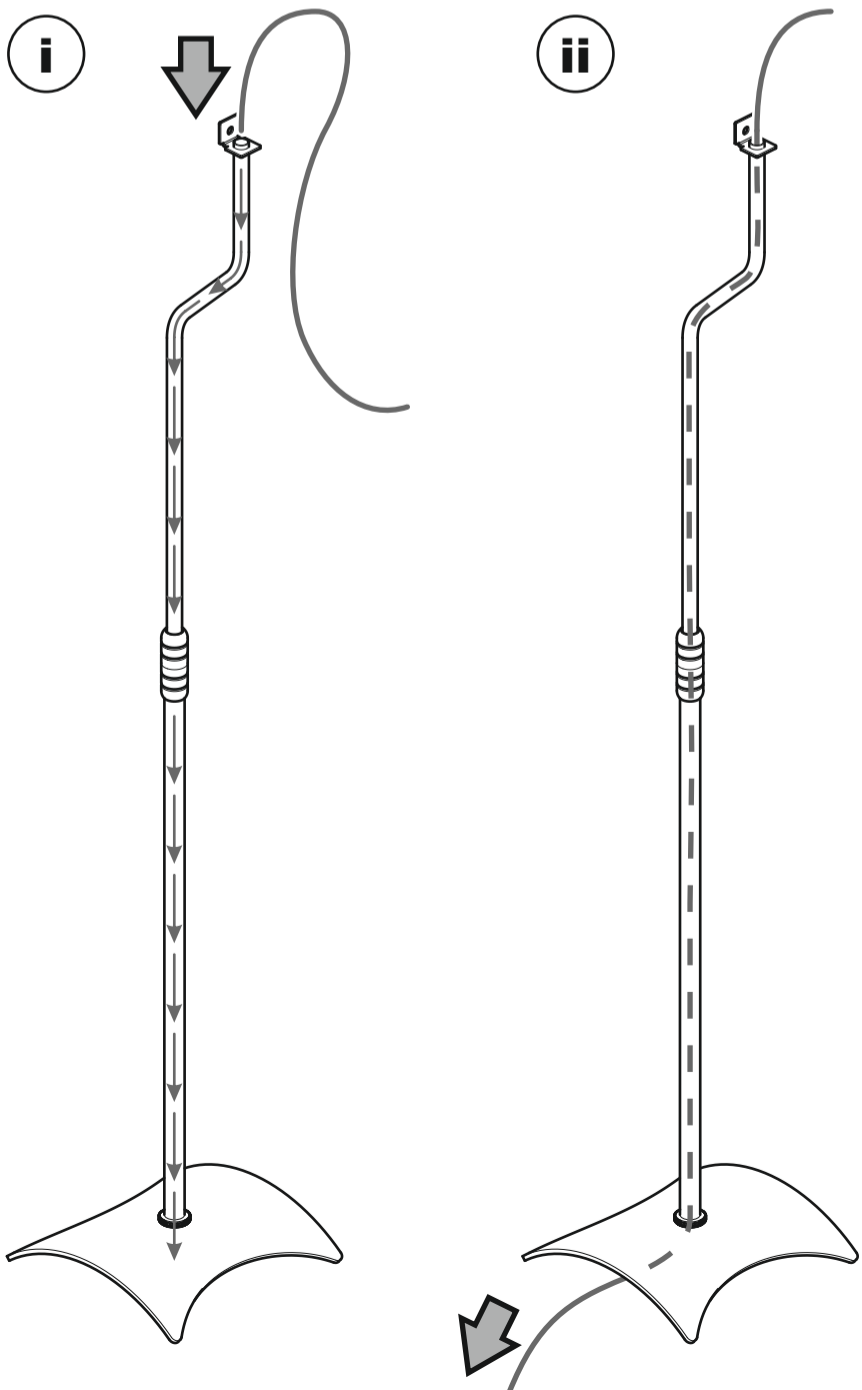

**5** Fit the Speakers  
Coloque los altavoces

Keyhole Fixing  
Ajuste de la bocallave

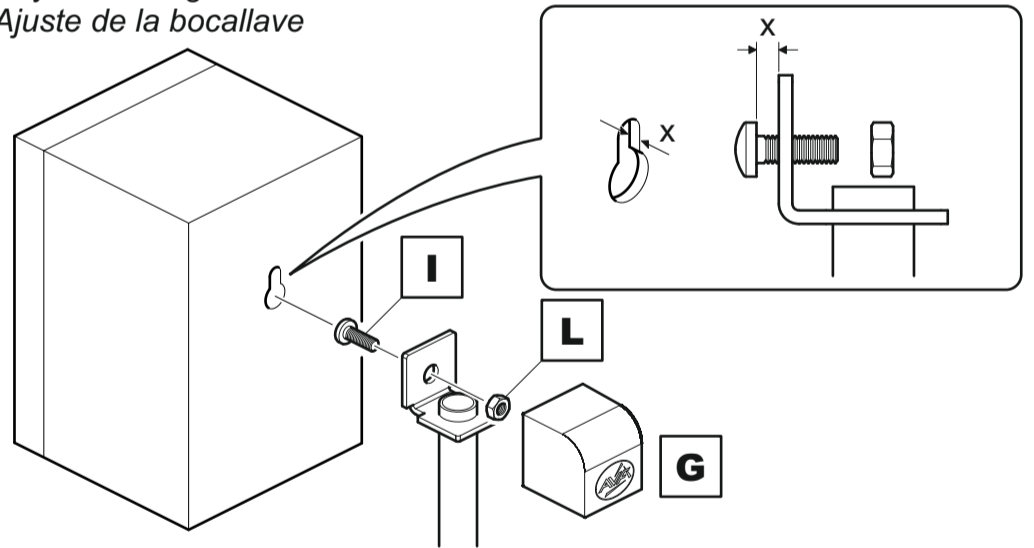

Threaded Hole Fixing  
Ajuste del orificio roscado

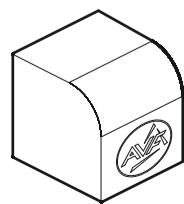
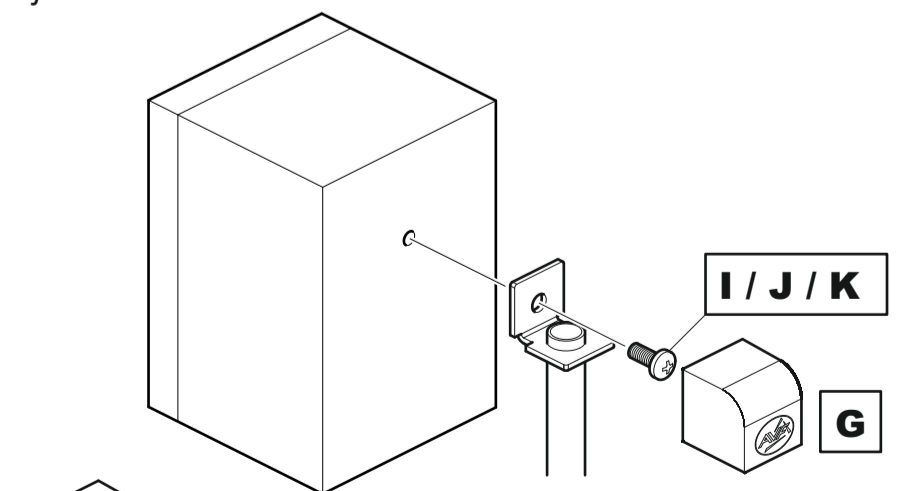

**G** x2

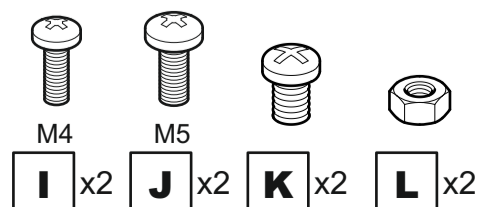

**I** x2 **J** x2 **K** x2 **L** x2