

472157 rev00

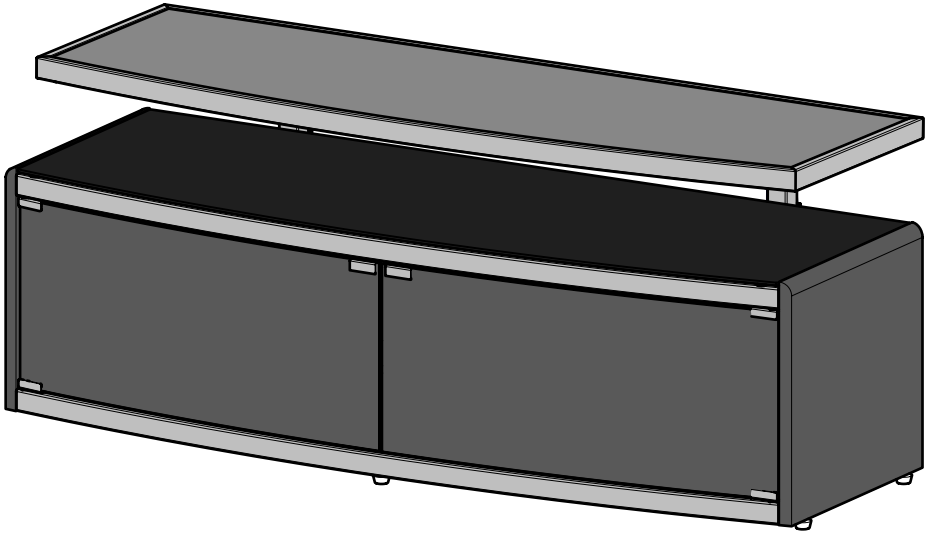

www.avfgroup.com

45kg
99lb

STOP

Read through **ALL** instructions before commencing installation.

If you have any questions about this product or issues with installation, contact the customer services helpline before returning this product to the store.

ARRÊT

Lisez **TOUTES** les instructions avant de débiter l'installation.

Si vous avez des questions sur ce produit ou des problèmes d'installation, contactez l'assistance client avant de ramener le produit en magasin.

ALTO

Lea **TODAS** las instrucciones antes de comenzar la instalación.

Si tiene alguna pregunta sobre el producto o problemas con la instalación, llame a la línea de servicio al consumidor antes de devolverlo.

CUSTOMER SERVICES HELPLINE NUMBER: **+44 (0) 333 320 0463 (UK)**
NUMÉRO DE L'ASSISTANCE CLIENT:
NUMERO DE SERVICIO DE ATENCION AL CLIENTE: **1-800 667 0808 (USA)**

IMPORTANT INFORMATION!

We advise that before starting the assembly of this product that you familiarise yourself with the instructions and the parts list in this leaflet.

INFORMATIONS IMPORTANTES!

Nous vous recommandons de vous familiariser avec ces instructions et la liste des pièces détachées contenues dans ce document avant de commencer l'assemblage de ce produit.

INFORMACIÓN IMPORTANTE!

Le recomendamos que antes de comenzar el ensamblaje de este producto se familiarize con las instrucciones y la lista de partes en esta hoja informativa.

Do not's

Do not overtighten any part of this assembly.

Do not place hot or cold objects on to or close next to any glass surface unless the object is sufficiently insulated to prevent contact.

Do not strike the glass with hard or pointed items.

Do not use the product if the glass is chipped or damaged.

Do not sit or stand upon horizontal glass surfaces.

Do not use washing powders or other substances containing abrasives when cleaning the glass.

À ne pas faire

Ne serrez pas trop fort aucun des éléments de cet assemblage.

Ne placez aucun objet froid ou chaud sur ou à proximité de toute surface en verre à moins que celui-ci ne présente une isolation suffisante pour empêcher tout contact.

Ne frappez pas les surfaces en verre avec des objets lourds ou pointus.

N'utilisez pas le produit si le verre est ébréché ou endommagé.

Ne vous asseyez ni ne montez pas sur les surfaces horizontales en verre.

N'utilisez pas de poudre à récurer ou toute autre substance abrasive lorsque vous nettoierez les surfaces en verre car cela risquerait de provoquer des rayures.

No haga

No apriete demasiado ninguna de las piezas de este soporte.

No coloque objetos calientes o fríos en o cerca de cualquier superficie de vidrio, a menos que el objeto esté aislado para prevenir contacto directo.

No golpee el vidrio con artículos fuertes o punzantes.

No usar el producto si el cristal está astillado o dañado.

No se sienta o se pare en superficies de vidrio.

No use detergentes para lavar u otras sustancias que contengan abrasivos cuando esté limpiando el vidrio ya que estas pueden rayarlo.

Do's

Do use a damp cloth with diluted washing up liquid for cleaning the glass surfaces.

Check all nuts and bolts from time to time.

À faire

Utilisez un chiffon humide imprégné de liquide vaisselle dilué pour le nettoyage des surfaces en verre.

Vérifiez tous les écrous et les boulons de temps à autre.

Si haga

Use un trapo suave con líquido diluido en agua para limpiar las superficies de vidrio.

Compruebe todos los tornillos y tuercas de vez en cuando.

Maximum TV weight and shelf capacities

Poids maximal du téléviseur et capacité de charge de l'étagère

Máximo peso y capacidad del estante de TV

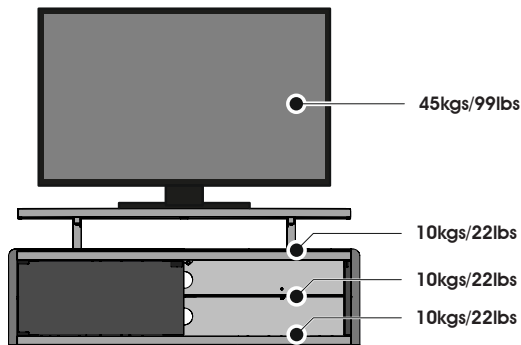

WARNING: Wherever possible distribute weight evenly.

AVERTISSEMENT: Répartissez le poids de manière uniforme lorsque cela est possible.

ADVERTENCIA: En la medida de lo posible distribuya el peso uniformemente.

Height and Colour Options
Options de hauteur et de couleur
Opciones de color y altura

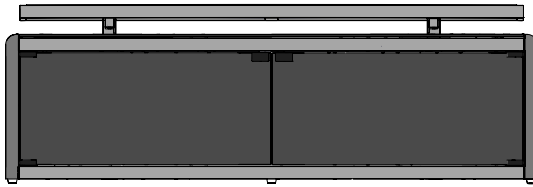

Low
Basse
Bajo

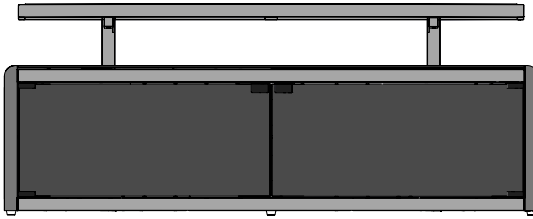

Medium
Moyen
Medio

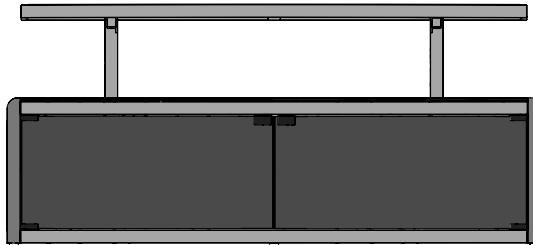

High
Haute
Alto

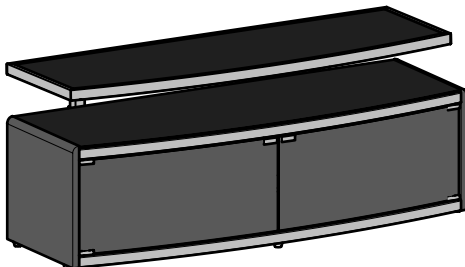

Black
Noir
Negro

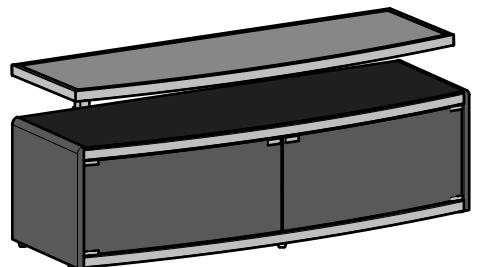

Walnut
Noyer
Nuez

Boxed Parts
Pièces empaquetées
Piezas en la Caja

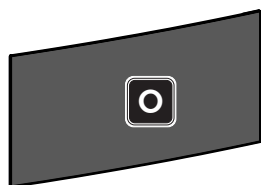
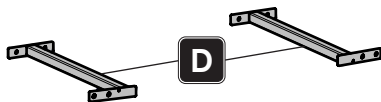
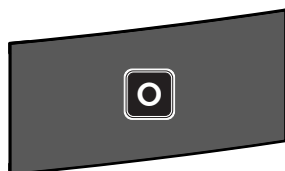
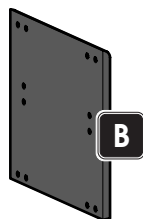
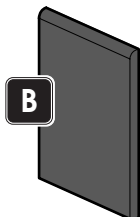
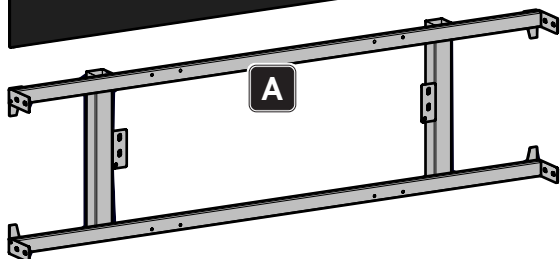
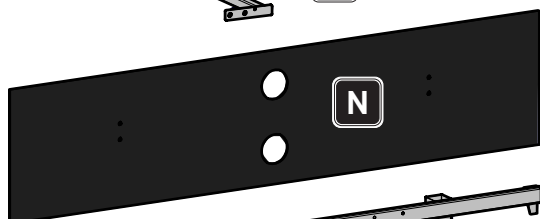
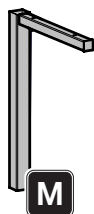
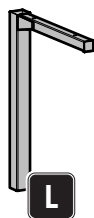
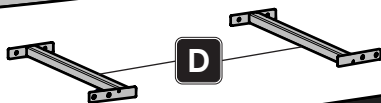
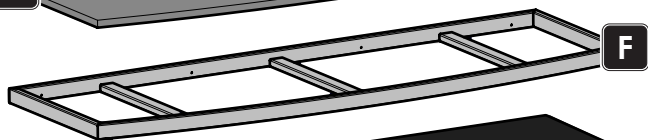
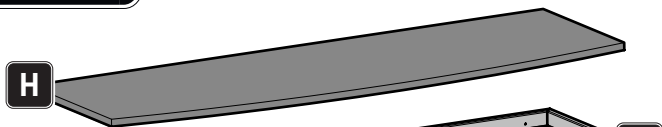

Tools Recommended
Outils recommandés
Herramientas recomendadas

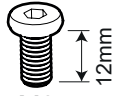
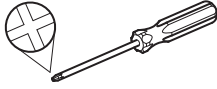

M6

P
X40

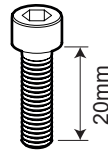

M6

Q
X4



R
X4



S
X12

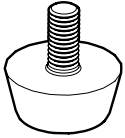

T
X6



U
X2

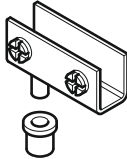

V
X2

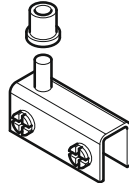

W
X2



X
X1

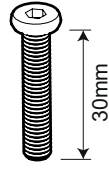

M6

Y
X4

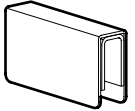

Z
X2

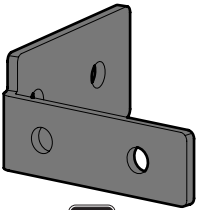

AA
X2

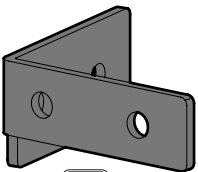

AB
X2



AC
X1

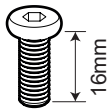

M6

AD
X2

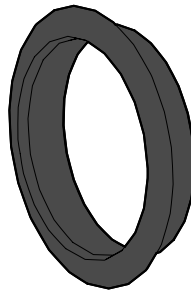

AE
X2



AF
X4



AG
X2

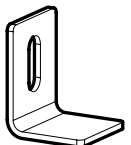

AH
X2

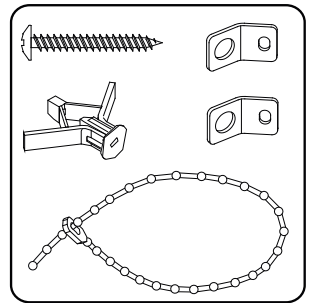

TR
X1

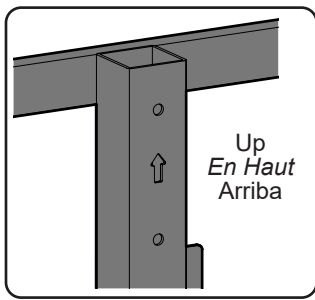
1

DO NOT fully tighten
Ne serrez pas à fond
No ajuste completamente

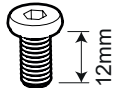
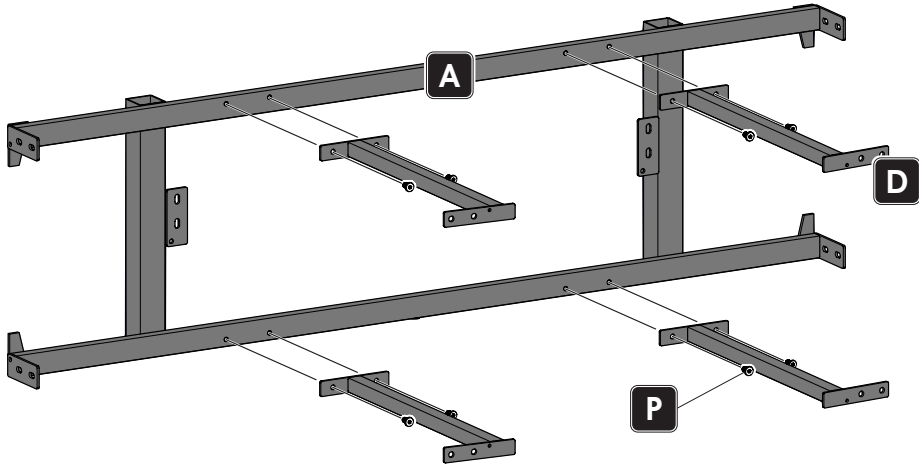

M6

P

X8

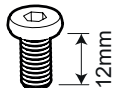
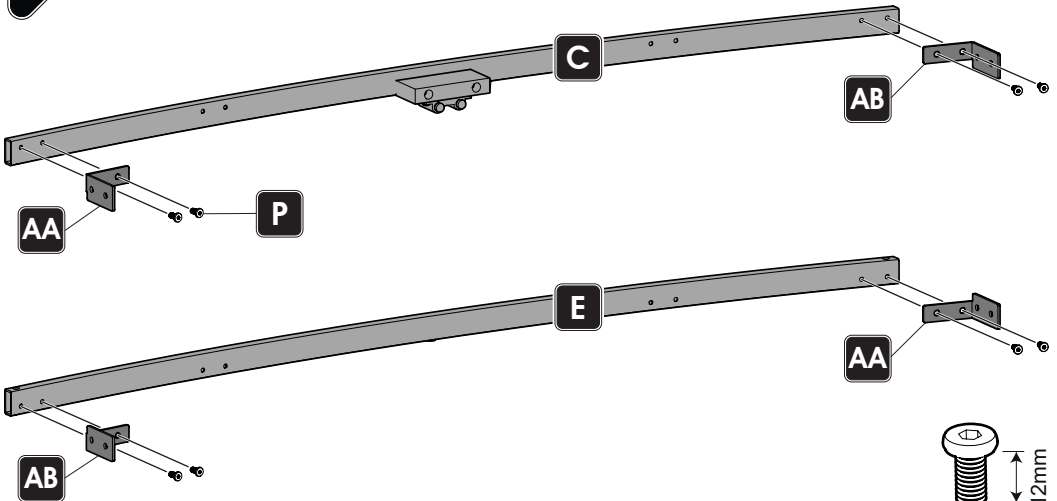
2

M6

P

X8

3

DO NOT fully tighten
Ne serrez pas à fond
 No ajuste completamente

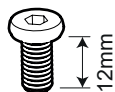

M6

P

X8

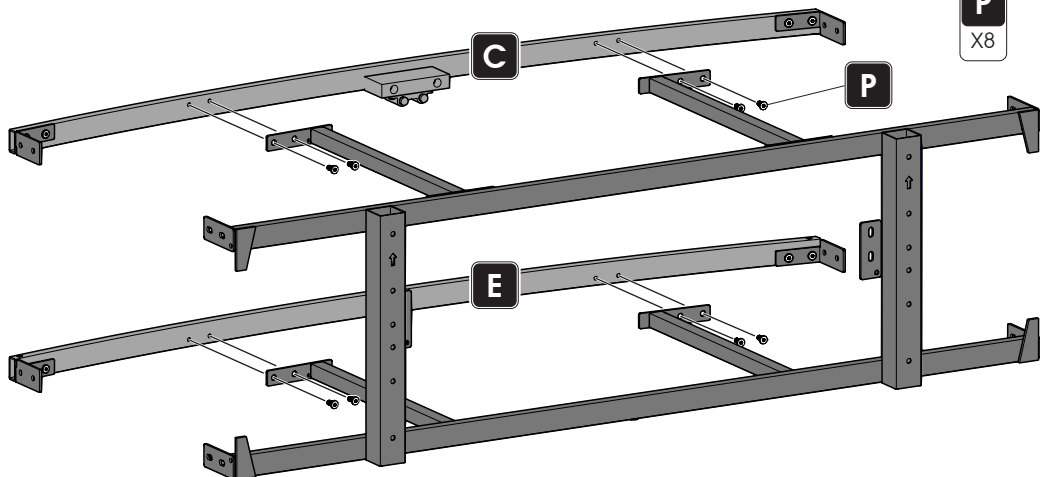
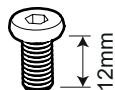
**4**

M6

P

X16

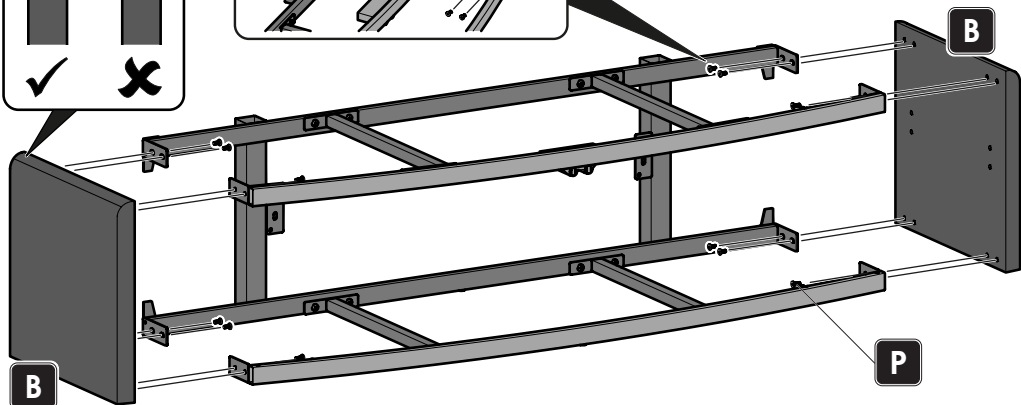
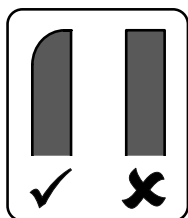
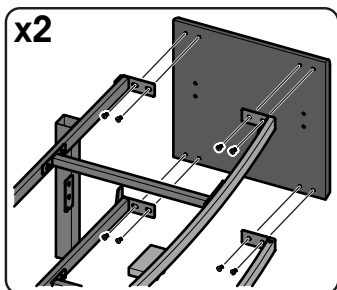

Fully tighten all screws when frame is square and level.
Serrer à fond toutes les vis lorsque le cadre est à l'équerre et de niveau.
 Apriete por completo todos los tornillos cuando el marco esté recto y nivelado.

5

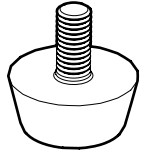
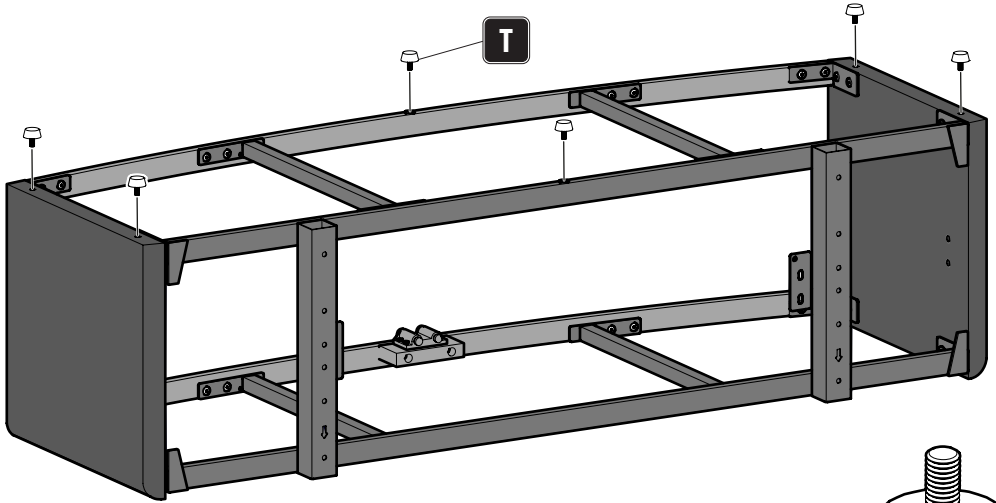

T
X6

6



U
X2

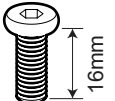

M6
16mm
AD
X2

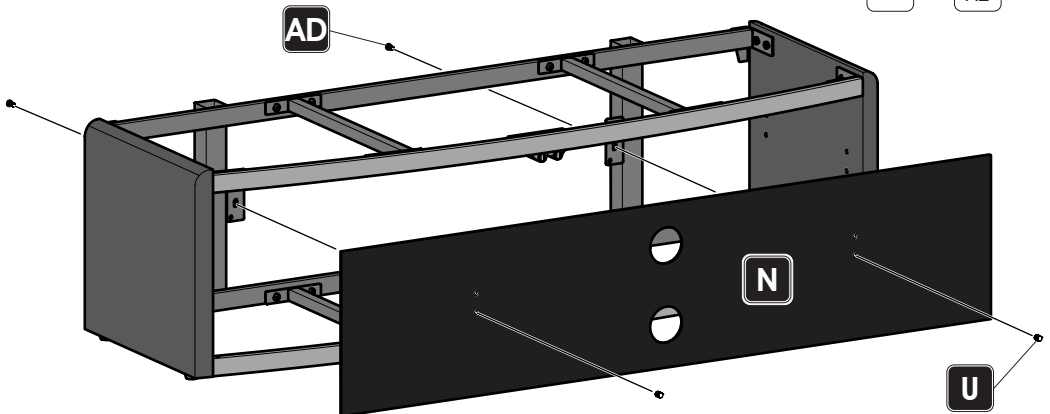

7

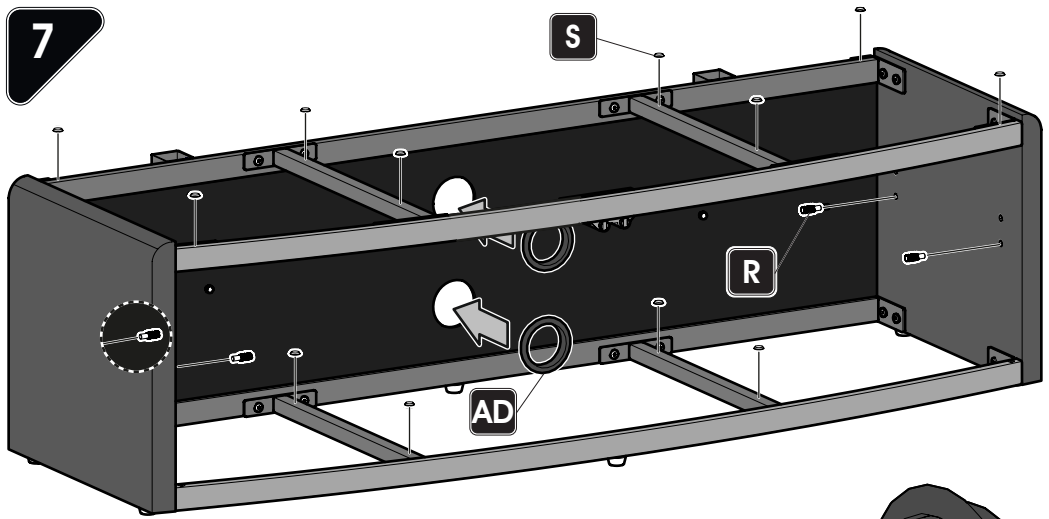

R
X4



S
X12

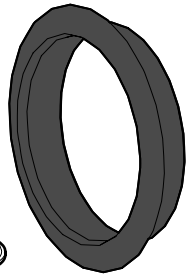

AE
X2

8

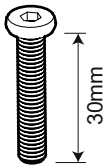
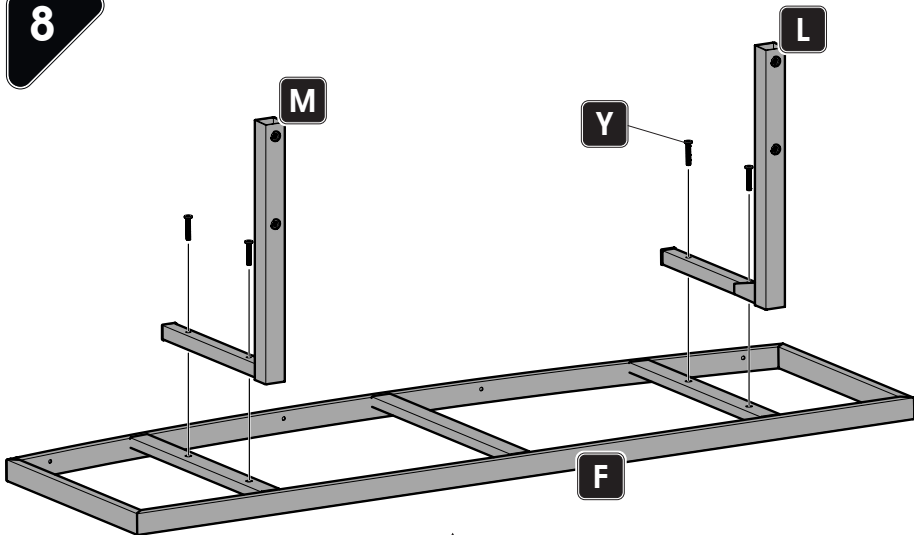

M6

Y
X4



DO NOT fully tighten
Ne serrez pas à fond
No ajuste completamente

9

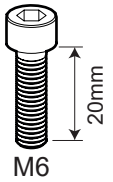
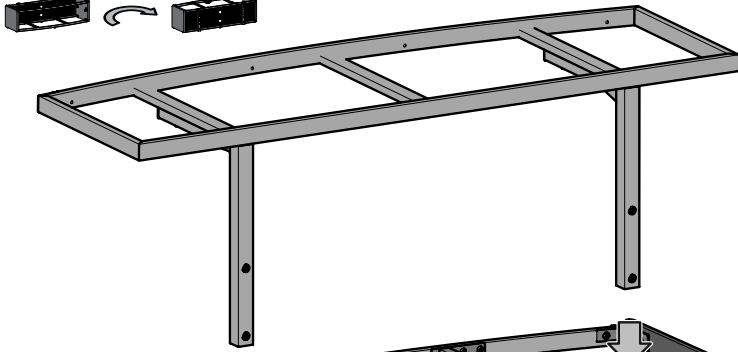

M6

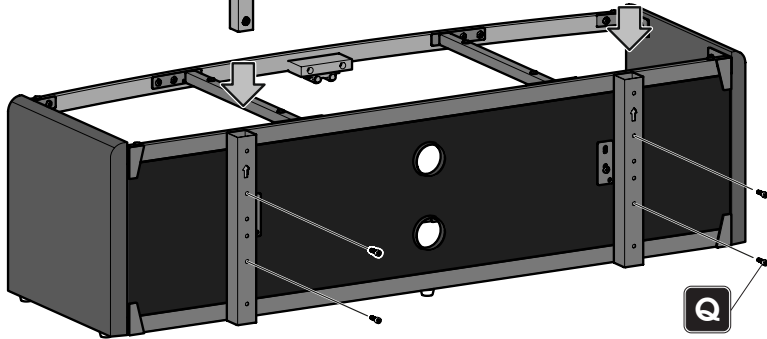

Each bracket must be secured by two screws.
Chaque support doit être fixé par deux vis.
Cada soporte debe estar sujeta con dos tornillos.

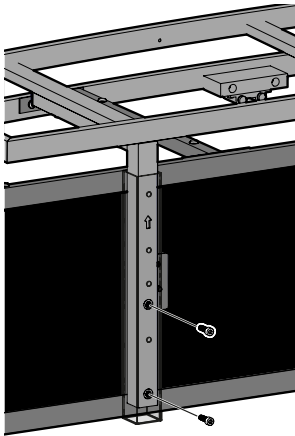

Low
Basse
Bajo

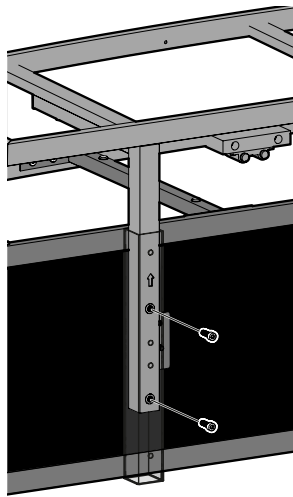

Medium
Moyen
Medio

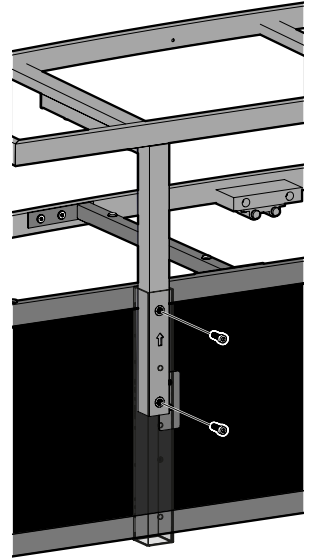

High
Haute
Alto



Fully tighten all screws when frame is square and level.
Serrer à fond toutes les vis lorsque le cadre est à l'équerre et de niveau.
Apriete por completo todos los tornillos cuando el marco esté recto y nivelado.

10



For TVs with peripheral legs
Pour les télé sur pieds latéraux
Para televisiones con patas periféricas

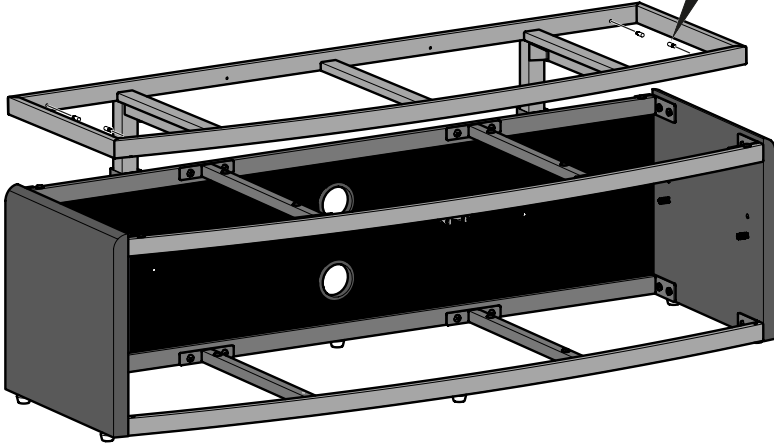
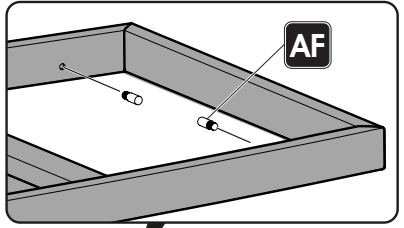

AF
X4



For TVs with a central stand
Pour les télé sur socle central
Para televisiones con soporte central

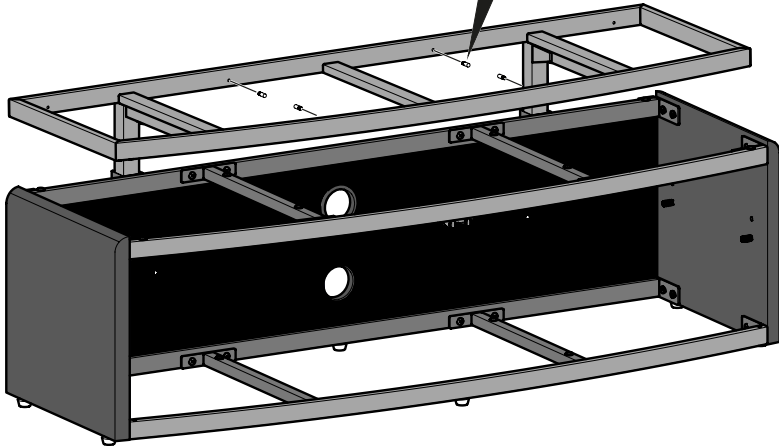
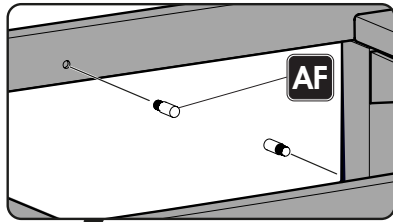

AF
X4

11

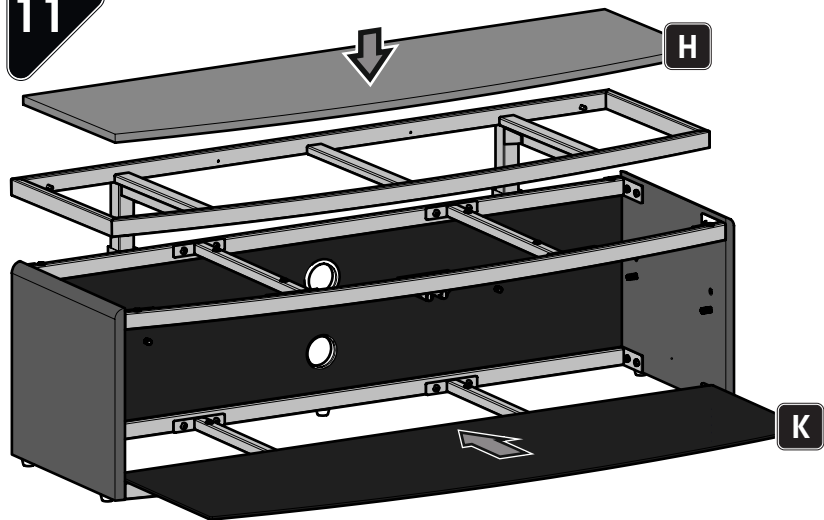

AG
X2

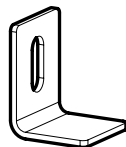

AH
X2

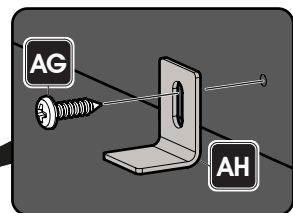
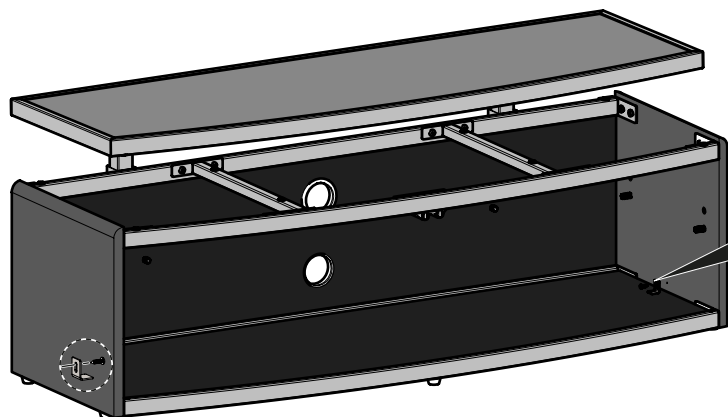

12

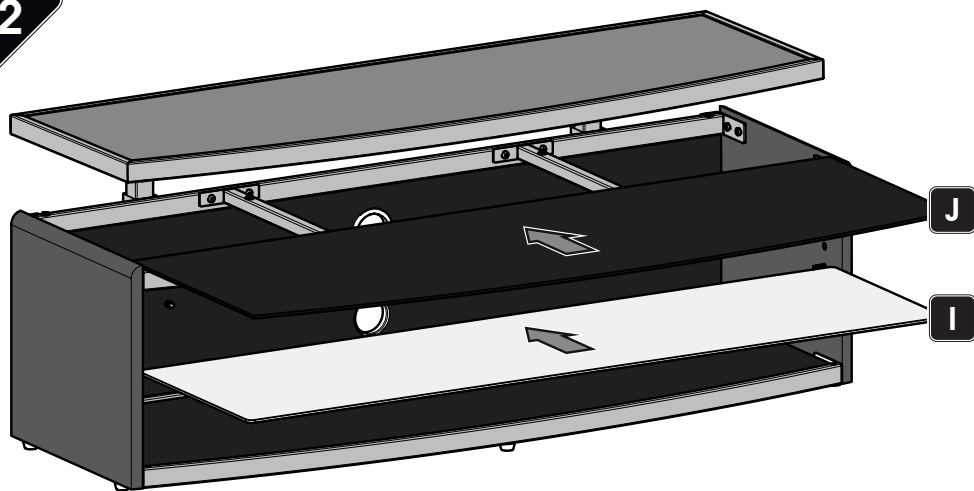

13

Doors are optional
Les portes sont optionnelles
Las puertas son opcionales



Take care
Faire attention
Tenga cuidado

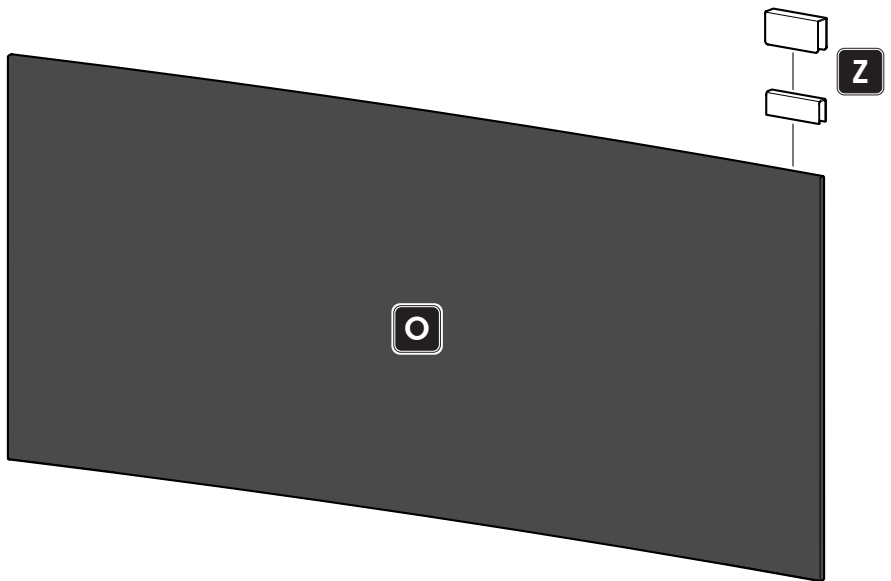
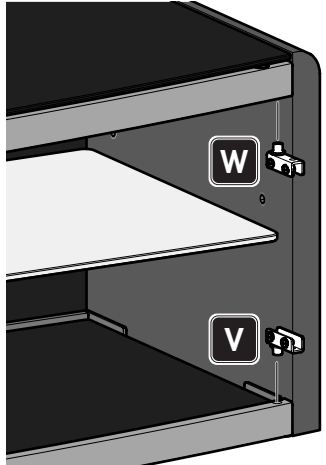
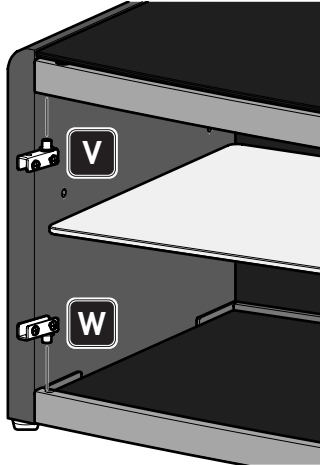
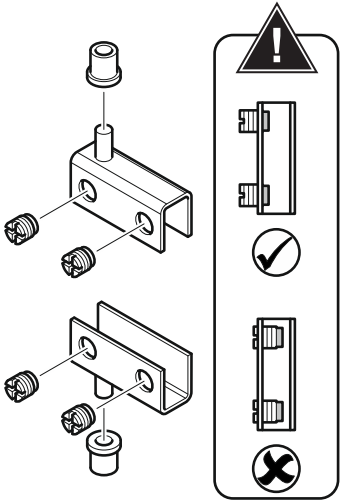

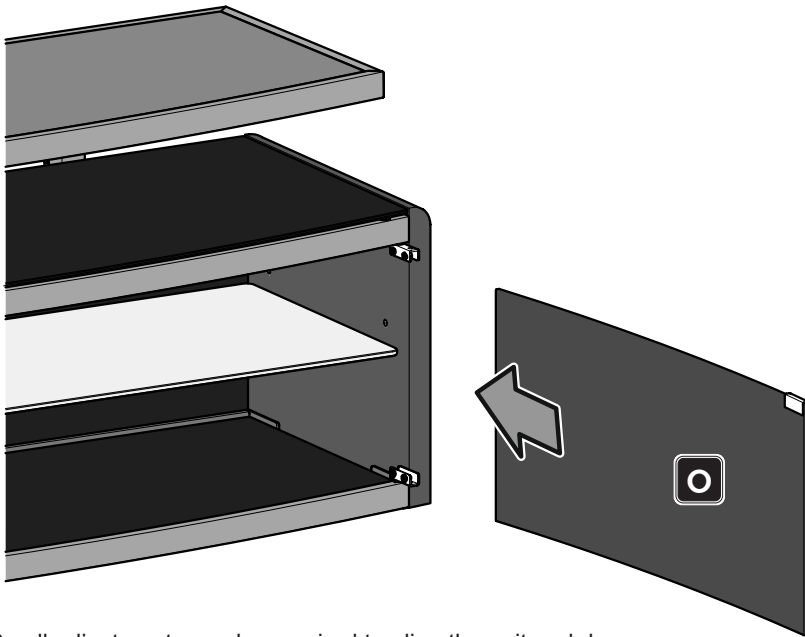

Small adjustments maybe required to align the unit and doors.
De légers ajustements pourront être requis pour aligner l'unité avec les portes.
Es posible que se requieran pequeños ajustes para alinear la unidad y las puertas.

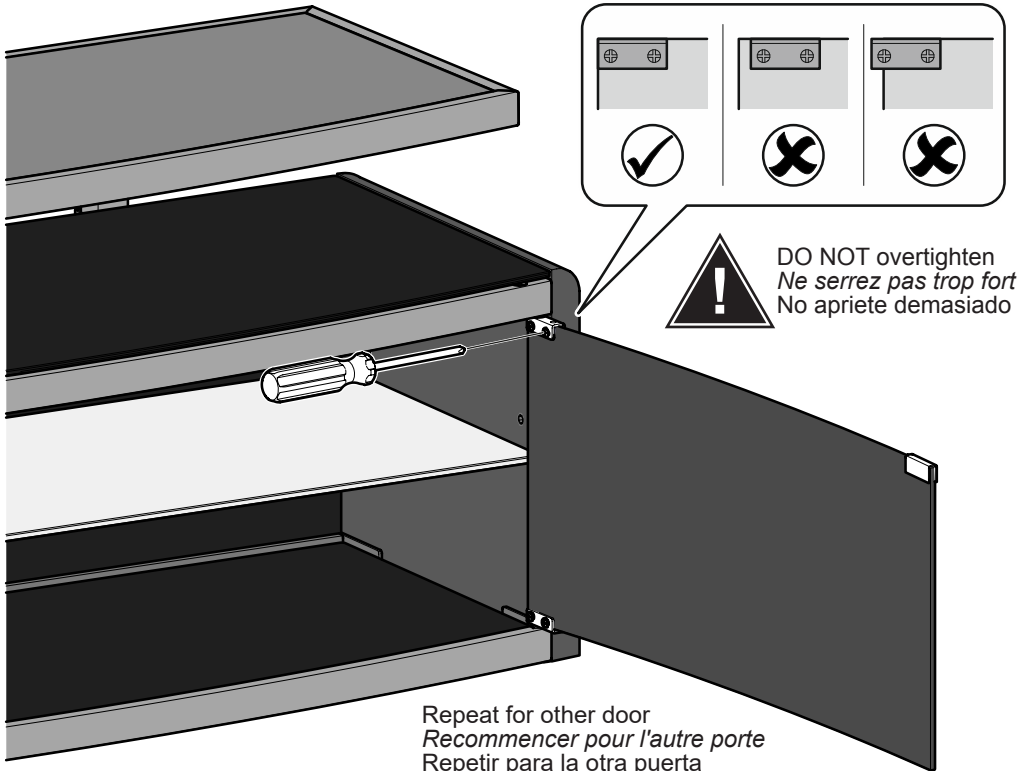

Repeat for other door
Recommencer pour l'autre porte
Repetir para la otra puerta

Optional
Optionnel
Opcional

Tipping Restraint
Dispositif de retenue anti-basculement
Restricción de vertidos

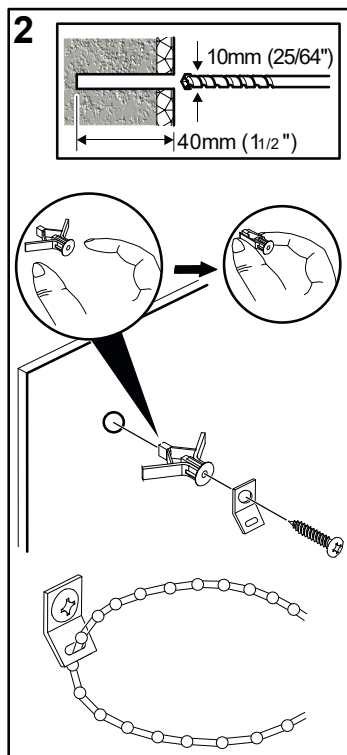
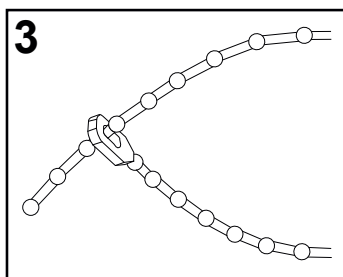
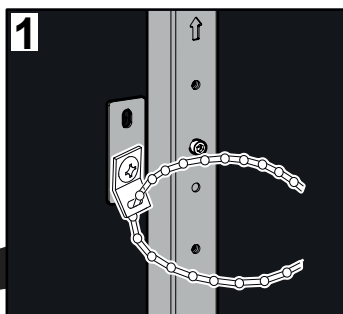
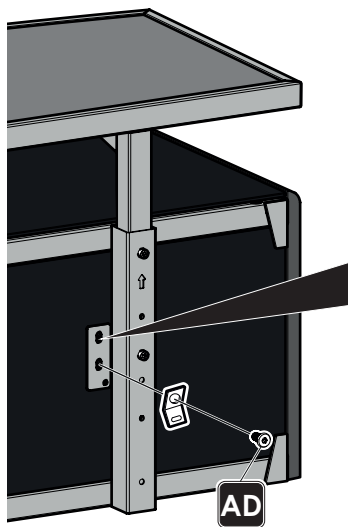

1. Attach one of the brackets to the back of the stand using screw **AD**. Position your stand against the wall and mark a drill point on the wall in line with the bracket.
2. Drill the wall. Pinch the wings of the wall anchor together and push fully in to the wall. Attach the second bracket with the screw provided.
3. Insert the restraint strap through both brackets then pull it through the keyhole slot until it is tight. Pull the end of the strap down until it locks into place in the keyhole slot. Pull the end of the strap back through the keyhole strap to double lock the restraint.

1. Fixez l'un des équerres à l'arrière du support à l'aide de la vis **AD**. Positionnez votre support contre le mur et faites une marque sur le mur en ligne avec le support.
2. Percez le mur. Pincez les ailes de l'ancrage mural et insérez à fond dans le mur. Fixez le deuxième équerre à l'aide de la vis fournie.
3. Insérez la sangle de retenue dans les deux équerres, puis tirez-la dans la fente du trou de serrure jusqu'à ce qu'elle soit bien tendue. Tirez l'extrémité de la sangle jusqu'à ce qu'elle s'enclenche dans la fente du trou de serrure. Tirez le restant de la sangle en arrière à travers la sangle du trou de serrure pour doubler le dispositif de retenue.

1. Sujete uno de los soportes de sujeción a la parte trasera del soporte con el tornillo **AD**. Coloque el soporte contra la pared y señale el punto para taladrar en la pared en línea con el soporte de sujeción.
2. Taladre la pared. Una con firmeza las alas del anclaje de pared y empújelo a fondo en la pared. Sujete el segundo soporte de sujeción con el tornillo provisto.
3. Inserte la correa de restricción a través de los dos soportes de sujeción y tire luego de ella a través de la ranura del ojo de la cerradura hasta que esté prieta. Tire del extremo de la correa hacia abajo hasta que quede sujeta en su sitio en la ranura del ojo de la cerradura. Vuelva a tirar de la correa a través del ojo de la cerradura para que esté doblemente sujeta.

Change Colour Options
Changer les options de couleur
Cambiar las opciones de color

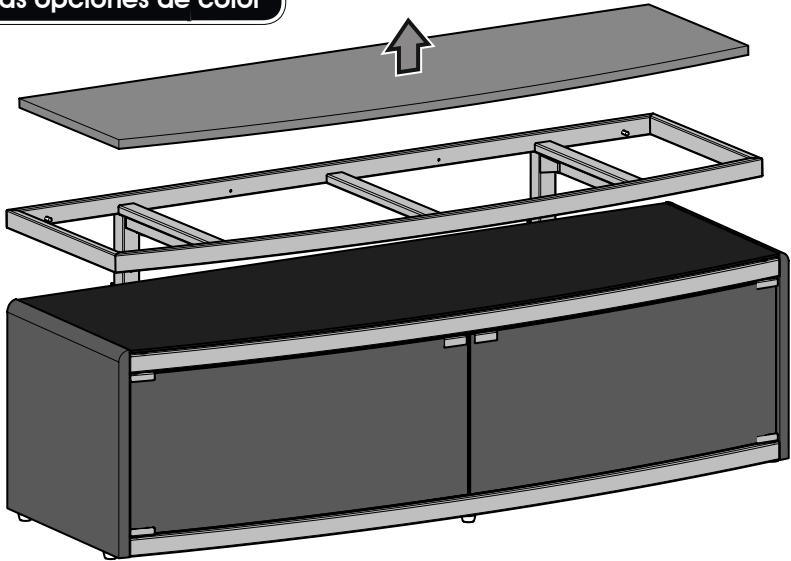

Remove trim panels and rotate to select preferred colour option.
Retirez le panneau de finition et faites-les pivoter pour sélectionner l'option de couleur préférée.
Elimina el panel de recorte y gira para seleccionar la opción de color preferido.

Change Height Options
Modifier les options de hauteur
Cambiar las opciones de altura



Remove TV before starting.
Retirez TV avant de commencer.
Extrae TV de empezar.



Each leg must be secured by two screws.
Chaque pied doit être fixé par deux vis.
Cada pata debe estar sujeta con dos tornillos.

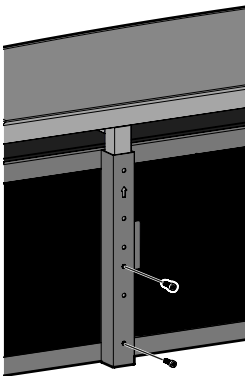

Low
Basse
Bajo

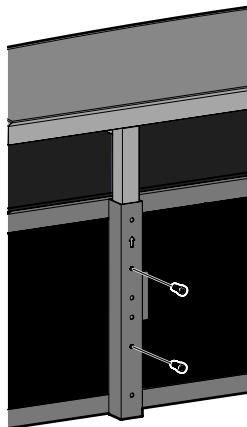

Medium
Moyen
Medio

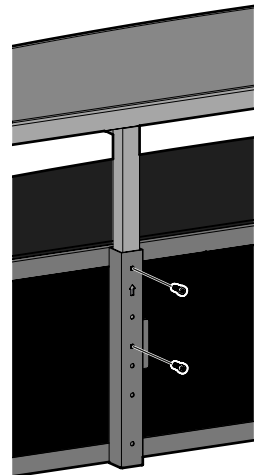

High
Haute
Alto