

30kg
66lb



10 kg
22 lb

Per Shelf
Par étagère
Por estante

469981rev00

IMPORTANT INFORMATION!

We advise that before starting the assembly of this product that you familiarise yourself with the instructions and the parts list in this leaflet.

INFORMATIONS IMPORTANTES!

Nous vous recommandons de vous familiariser avec ces instructions et la liste des pièces détachées contenues dans ce document avant de commencer l'assemblage de ce produit.

INFORMACIÓN IMPORTANTE!

Le recomendamos que antes de comenzar el ensamblaje de este producto se familiarize con las instrucciones y la lista de partes en esta hoja informativa.

Retain all packaging in case the product needs to be returned.

Contents may vary from photography / illustrations.

You will not need all these parts, so expect there to be some left over depending upon the specification of your TV.

This product is intended for indoor use only. Use of this product outdoors could lead to failure and personal injury.

Conserver tous les emballages au cas où ce produit devrait nous être renvoyé.

Les contenus peuvent varier de la photographie / illustrations.

Vous n'aurez pas besoin de toutes ces pièces, attendez-vous donc à ce qu'il reste des pièces selon les caractéristiques de votre téléviseur.

Ce produit est à utiliser à l'intérieur uniquement. Utiliser ce produit à l'extérieur causera des défaillances et de possibles accidents.

Conservar todos los embalajes en caso de que tenga que devolver este producto.

El contenido puede variar de la fotografía / ilustración.

No necesitará todas estas partes, espere que sobren algunas según las especificaciones de su TV.

Este producto está diseñado para el uso en el interior solamente. El uso de este producto en el exterior podría llevar al fracaso y lesiones personales.

Tools Recommended
Outils recommandés
Herramientas recomendadas

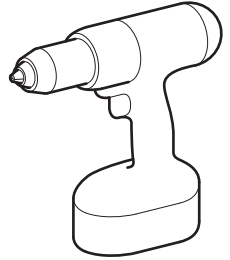
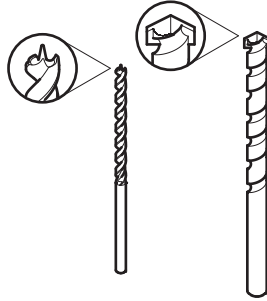
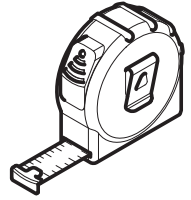
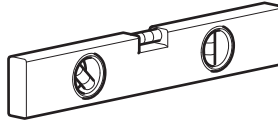
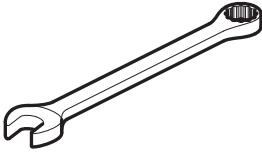
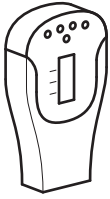

Boxed Parts
Pièces empaquetées
Piezas en la Caja

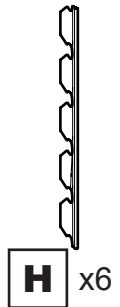
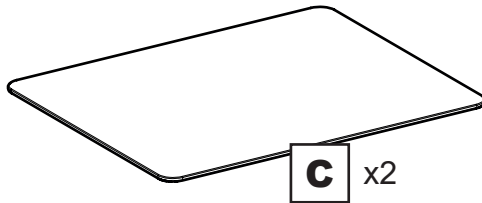
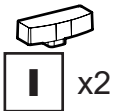
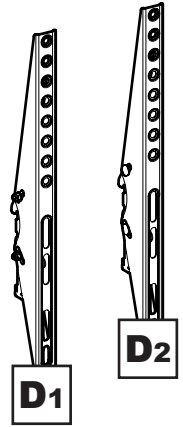
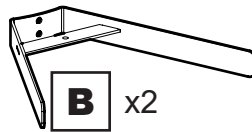
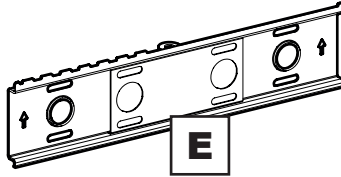
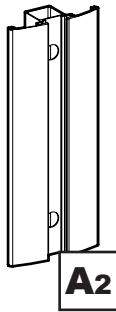
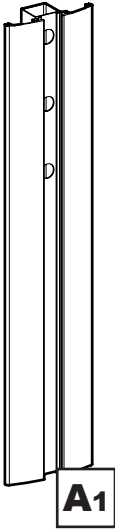
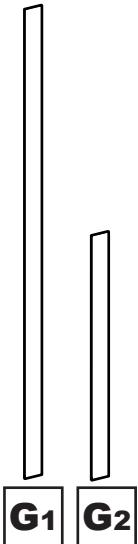

Boxed Parts
Pièces empaquetées
Piezas en la Caja

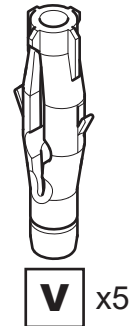
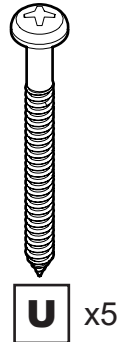
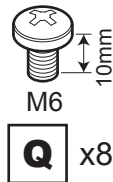
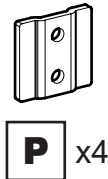
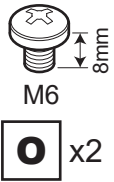
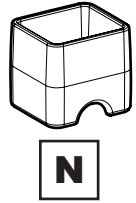
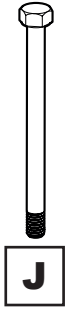

TV Screws, Reducers and Spacers
Vis TV, réducteurs et séparateurs
Tornillos, Reductores y Espaciadores para TV

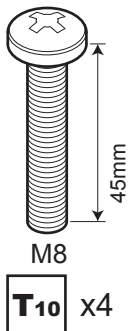
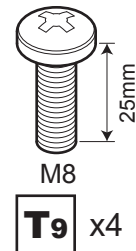
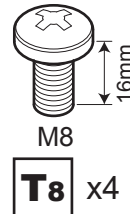
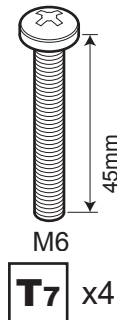
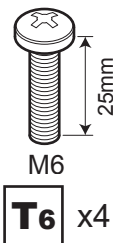
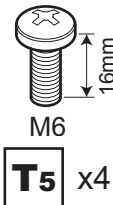
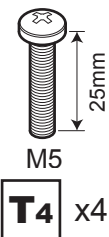
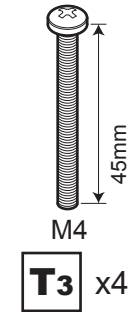
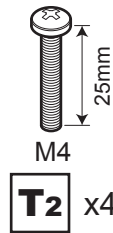
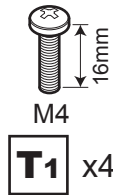
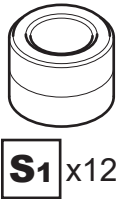

1

Measure the TV fixing holes Width and Height
 Mesurer la profondeur et la taille des trous de fixation
 Mida los orificios de su TV, lo ancho y lo alto

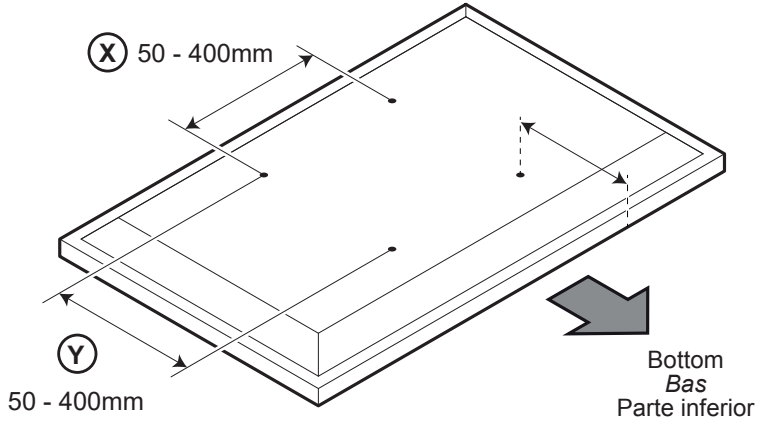

If width **(X)** is greater than 400mm or height **(Y)** greater than 400 mm, **OR** if the distance from the bottom fixing holes to the bottom of your TV is more than 240mm, **STOP** installation now and contact the customer helpline.

*Si la largeur **(X)** est plus large que 400mm et la hauteur **(Y)** plus grande que 400mm, **OU** si les mesures entre les trous de fixation de la partie basse et la base de votre téléviseur dépasse les 240 mm **ARRÊTEZ** l'installation immédiatement et contactez l'assistance client.*

Si la anchura **(X)** es mayor que 400mm o la altura de **(Y)** es mayor que 400mm **O** si la distancia desde los orificios inferiores de fijación a la parte inferior del televisor es superior a 240mm **DETENGA** la instalación inmediatamente y póngase en contacto con la línea de ayuda al cliente.

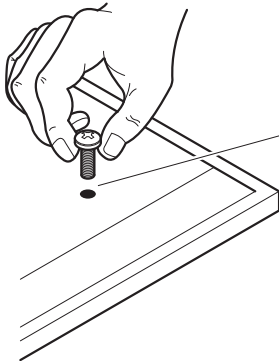

M4 =	T₁/T₂/T₃
M5 =	T₄
M6 =	T₅/T₆/T₇
M8 =	T₈/T₉/T₁₀

You are provided with 4 diameters of TV fixing screws, **M4**, **M5**, **M6** and **M8**. Determine the screw diameter that fits and remember for step 2.

*4 diamètres de vis TV vous sont fournis : **M4**, **M5**, **M6** y **M8**. Déterminez le diamètre de la vis qui convient et mémorisez- le pour l'étape 2.*

Se le proporciona con 4 diámetros de tornillos de fijación para su TV: **M4**, **M5**, **M6** y **M8**. Determine el diámetro del tornillo que le quede a su TV y recuérdelo para el paso 2.

No Spacers
 Pas de séparateur
 Sin espaciadores

For TVs with flat / unobstructed back
 Pour des téléviseurs aux dos
 plats et non obstrués
 Para TVs con la parte posterior
 plana / sin obstáculos

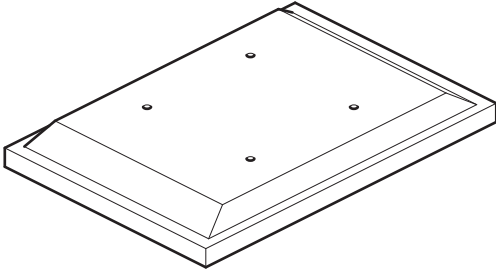

Spacers
 Séparateurs
 Espaciadores

S1/S2

For TVs with irregular / obstructed back
 Pour des téléviseurs aux dos
 irréguliers et non obstrués
 Para TVs con la parte posterior
 irregular / con obstáculos

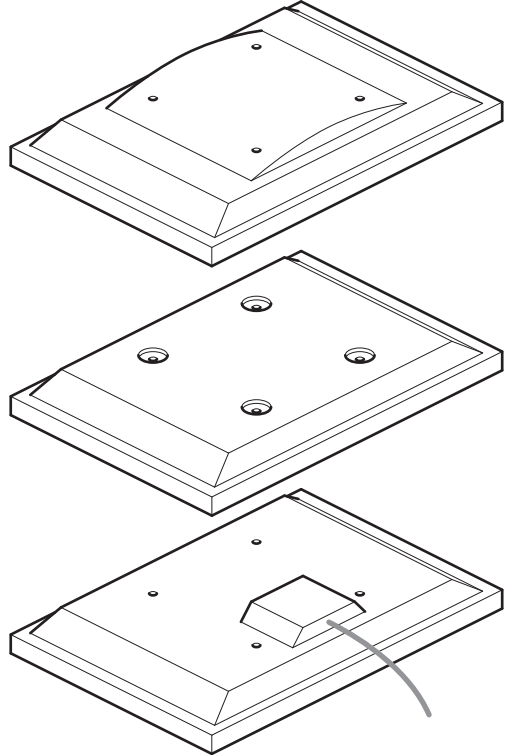

WARNING / AVERTISSEMENT / ADVERTENCIA

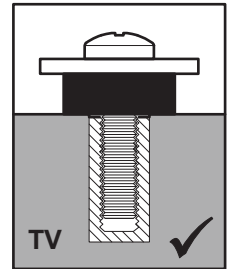
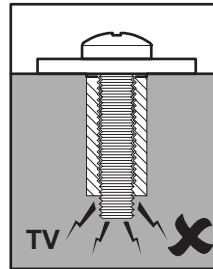
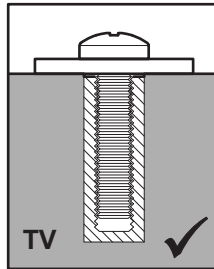
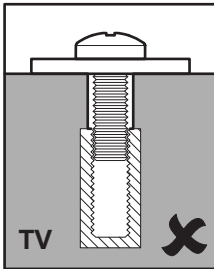

After completing step 2 you will have fittings left over, please keep for future reference.
 Après avoir complété l'étape 2 il vous restera des pièces d'assemblage, conservez-les.
 Después de completar el paso 2 usted tendrá conexiones sobrantes, por favor guarde
 para futura referencia.

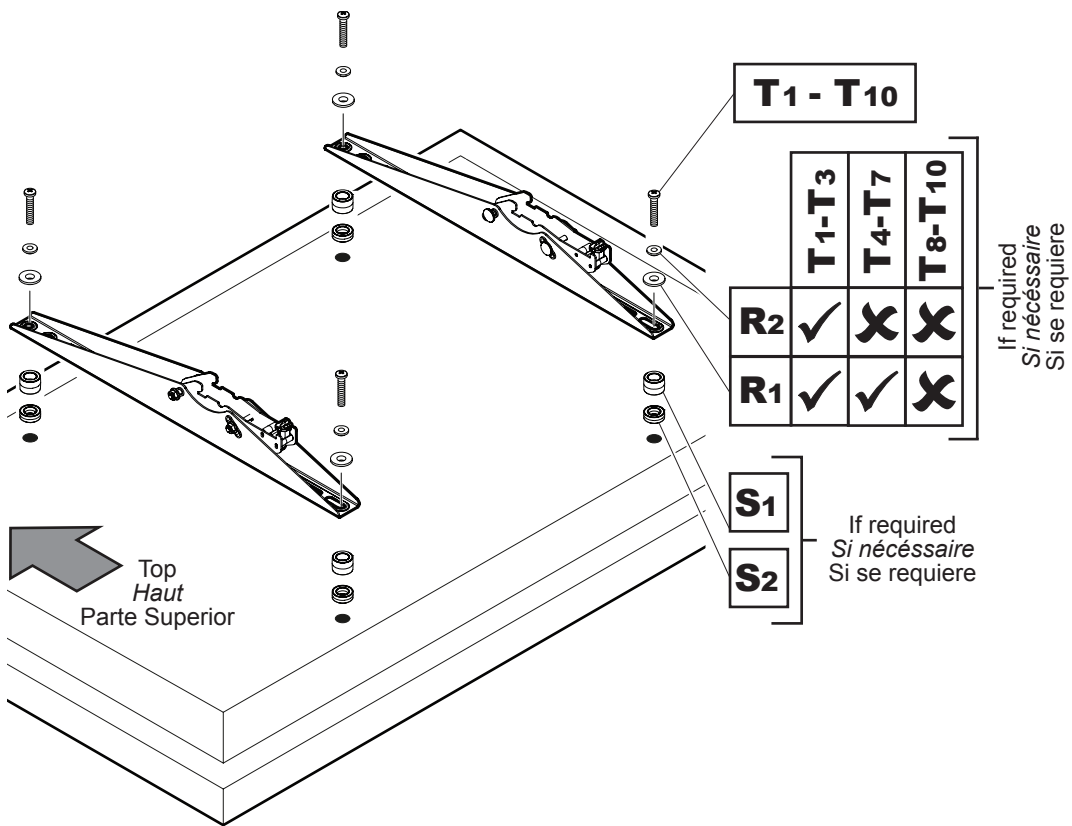

Attach the bracket to the back of your TV using suitable screw, reducer and spacer combinations.
Attachez l'applique au dos de votre téléviseur en utilisant une combinaison de vis, de séparateurs et de joints adaptés.

Coloque los soportes a la parte posterior de su TV usando la combinación adecuada de tornillo, reductor y espaciador.

3

Connecting the Wall Brackets
Connexion des fixations murales
 Conexión de los soportes de pared

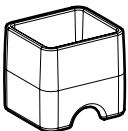
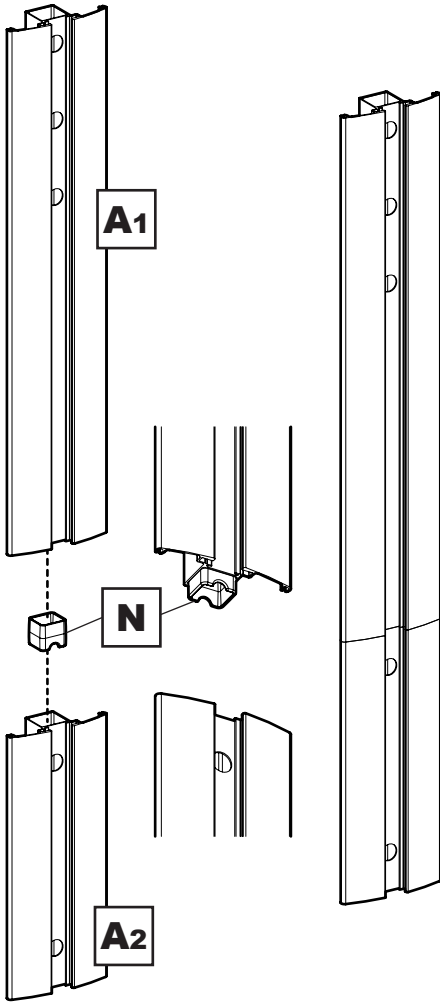
**N****4**

Assembling the Shelf and TV Support
Assemblage de l'étagère et du support pour TV
 Armado del estante y soporte de TV

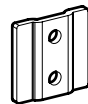
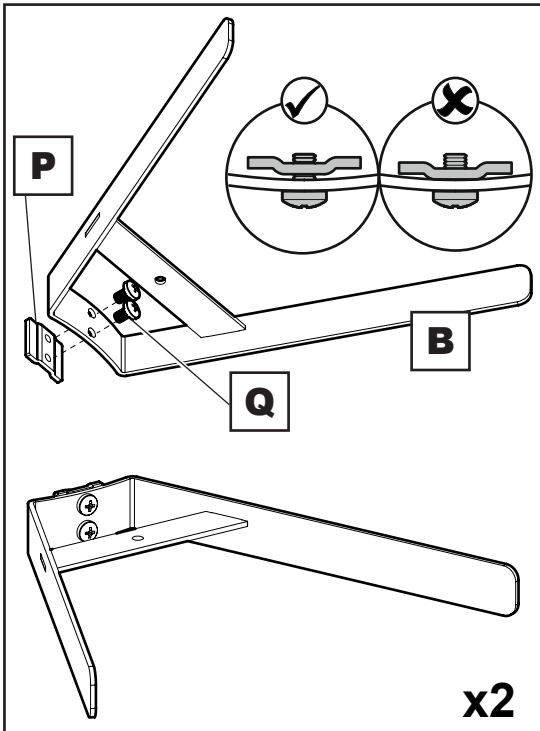
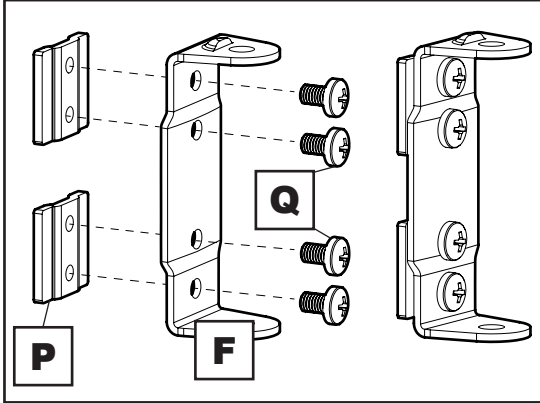
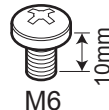
**P** x4**Q** x8

5

Fitting the Wall Bracket
Installer l'applique murale
Fijando la Placa a la Pared

Solid Wall
Mur solide
Pared sólida

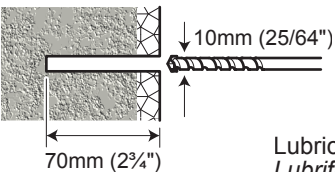
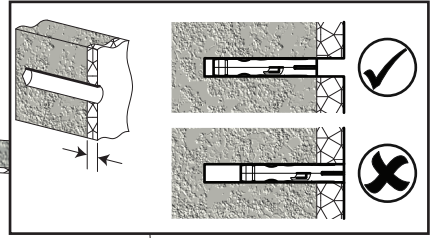
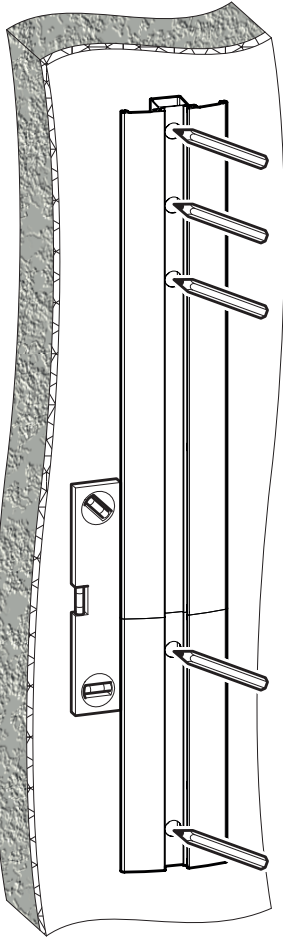

Lubricate screw thread with soap
Lubrifiez le pas de vis avec du savon
Lubrique la rosca del tornillo con jabón



Remove Dust from Hole
Retirez la poussière du trou
Elimine el polvo del agujero



DO NOT overtighten screws.
Tighten screws by hand only
Ne serrez pas trop les vis.
Visser à la main seulement
NO sobre apriete los tornillos.
Apriete los tornillos sólo a mano

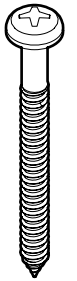
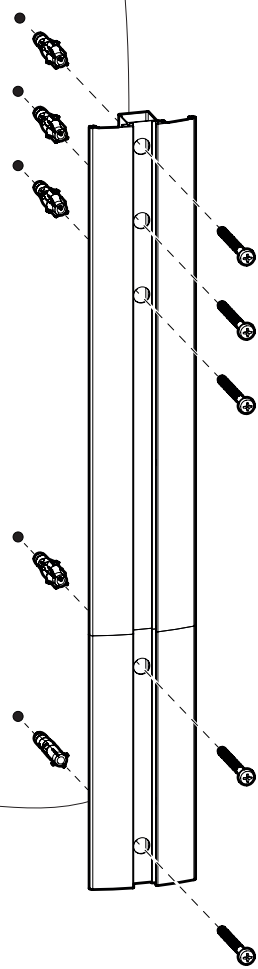

U x5

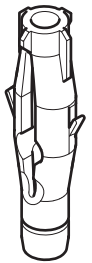

V x5

5

Fitting the Wall Bracket
Installer l'applique murale
Fijando la Placa a la Pared

Wood Stud
Latte de bois
Viga de madera

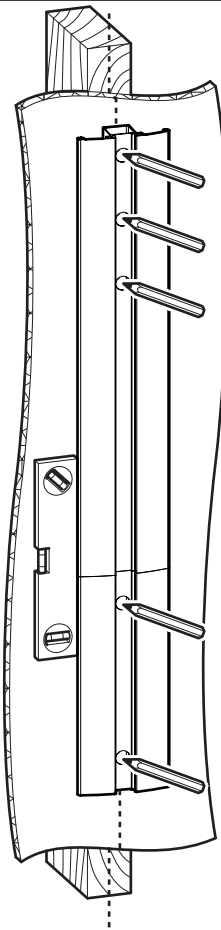

Ensure bracket is in the centre of the wood stud
Assurez-vous que l'applique est au centre de la latte de bois
Asegúrese de que el soporte está en el centro de la viga de madera

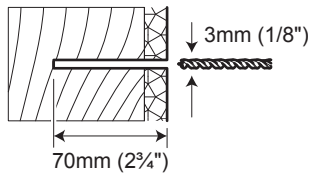
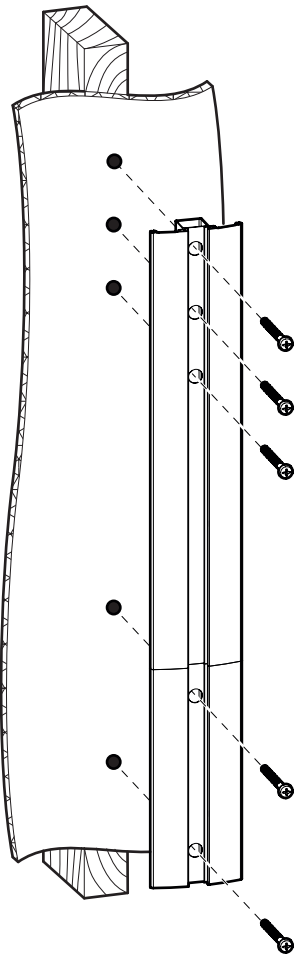
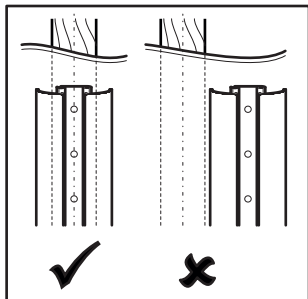

Lubricate screw thread with soap
Lubrifiez le pas de vis avec du savon
Lubricate the roscas del tornillo con jabón



DO NOT overtighten screws.
Tighten screws by hand only
Ne serrez pas trop les vis.
Visser à la main seulement
NO sobre apriete los tornillos.
Apriete los tornillos sólo a mano

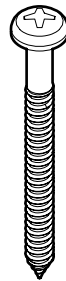

U x5

6

Fitting the Shelf Support
Fixer le support de l'étagère
Adaptación del soporte del estante

This way up
De cette façon jusqu'à
Por aquí hacia arriba

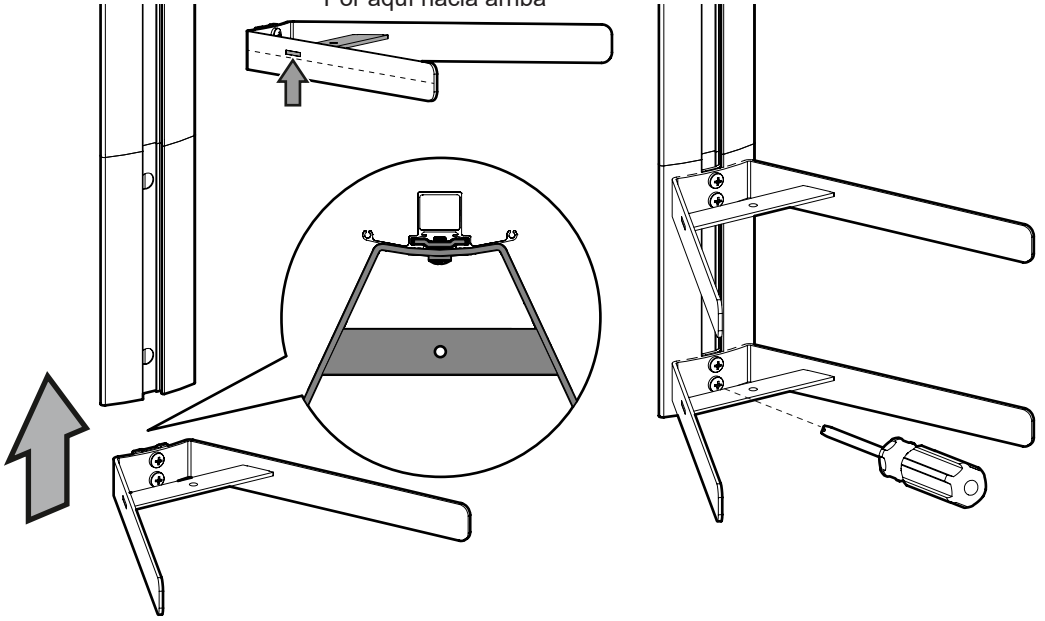

7

Fitting the TV Support Bracket
Montage de la fixation du support de la TV
Colocación de la ménsula del soporte de TV

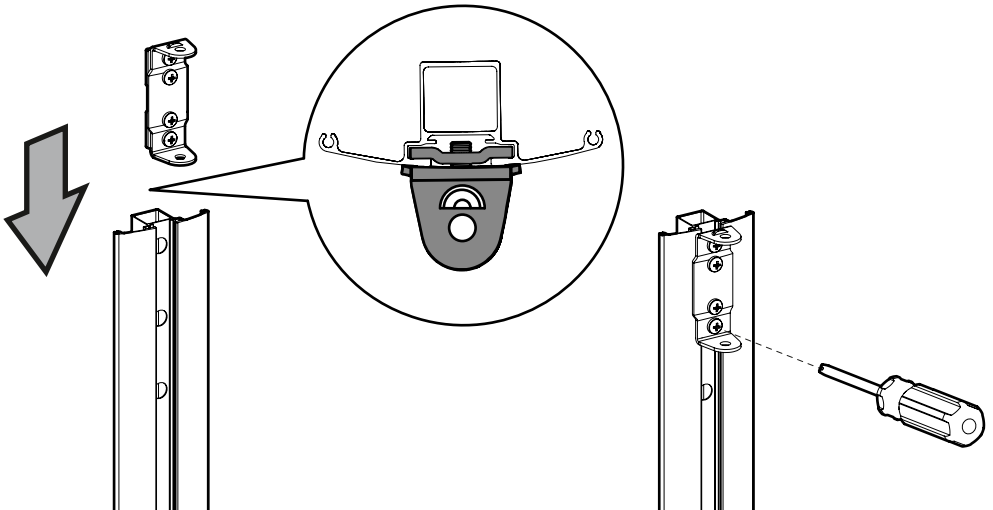

8

Fitting the End Caps and Cable Management *Montage des capuchons d'extrémité et ordonnancement des cordons* Colocación de terminales y organizador de cables

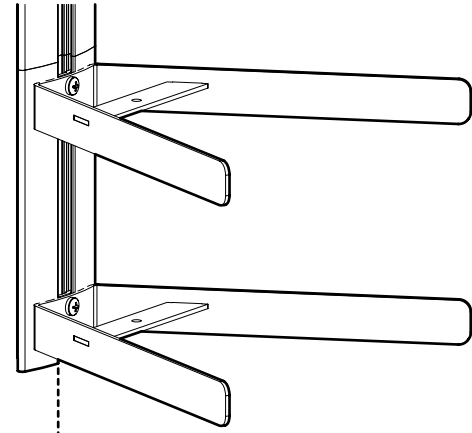

Tap into place
*Tapotez pour bien
mettre en place*
Golpetear hasta
poner en su lugar

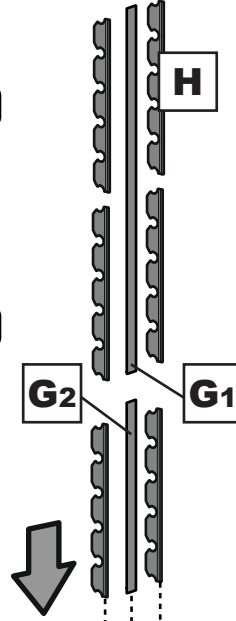
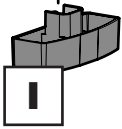

Tap into place
*Tapotez pour bien
mettre en place*
Golpetear hasta
poner en su lugar

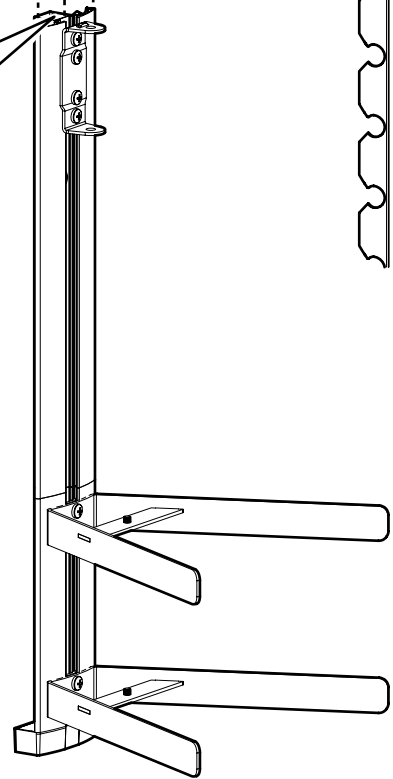
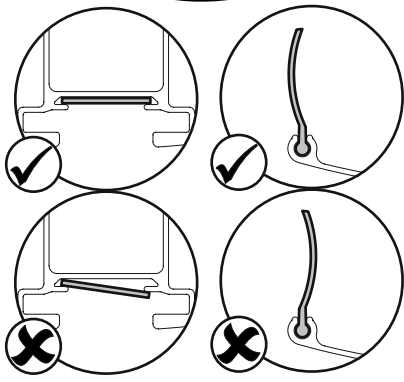
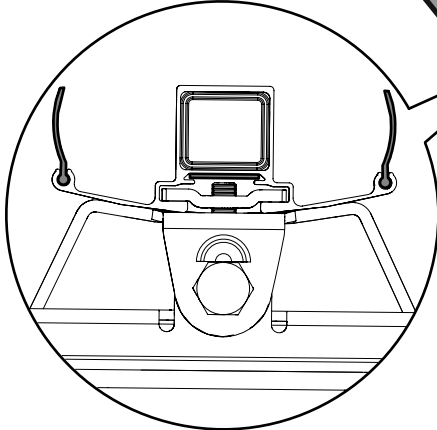
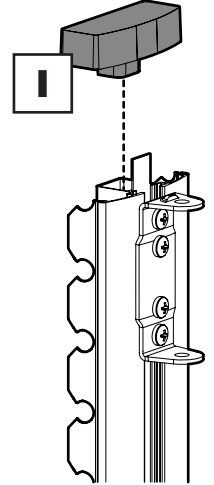

9

Fitting the TV Bracket
Montage de la fixation de la TV
Fije los Brazos del Soporte a su TV

Before tightening make sure the bolt is held in the position shown.
Avant de serrer, assurez-vous que le boulon est maintenu dans la position indiquée.
Antes de apretar, asegúrese de que el tornillo está sujeto en la posición mostrada.

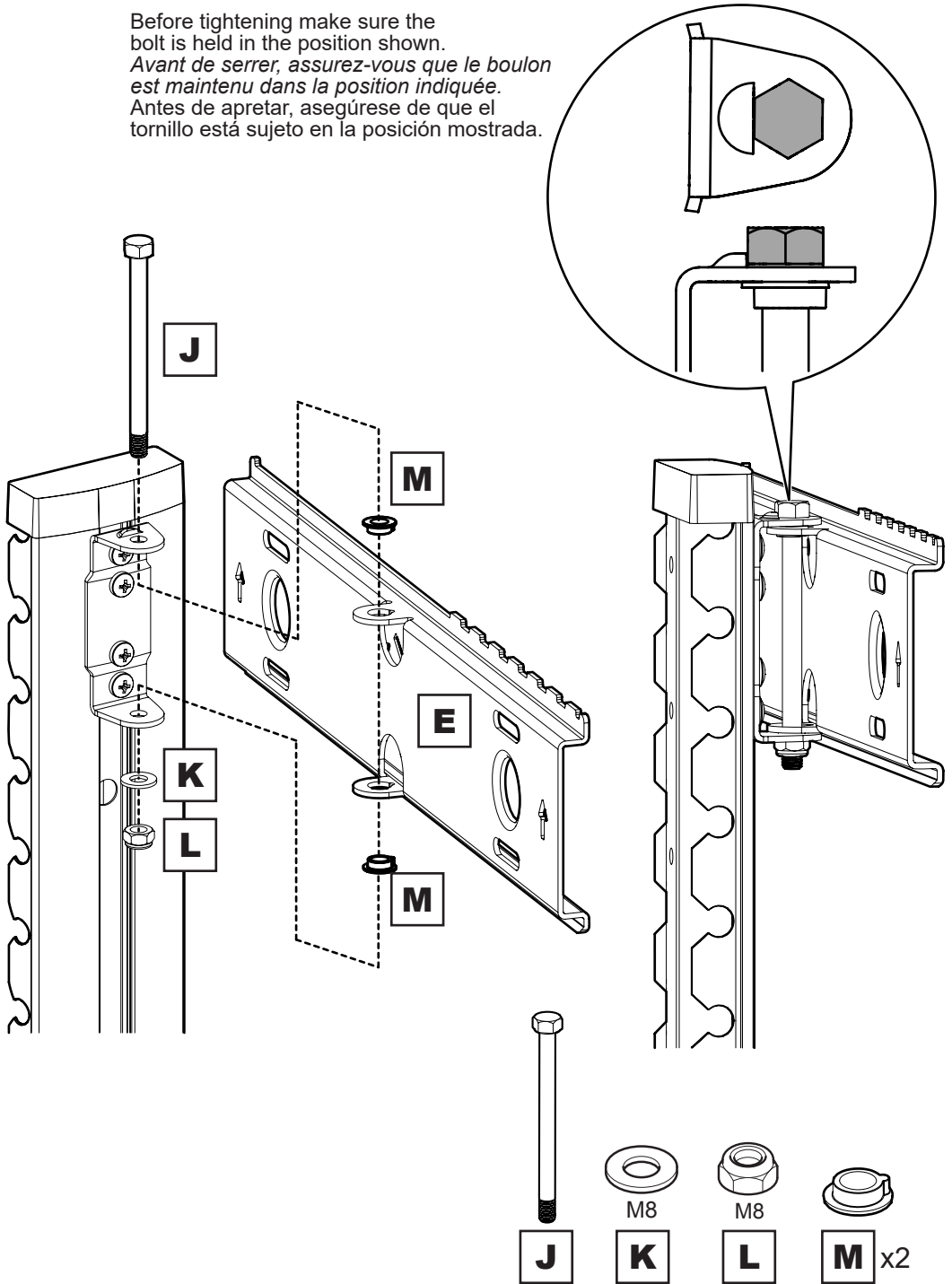

10

Fitting the Shelf
Fixer la étagère
Ajuste de la plataforma

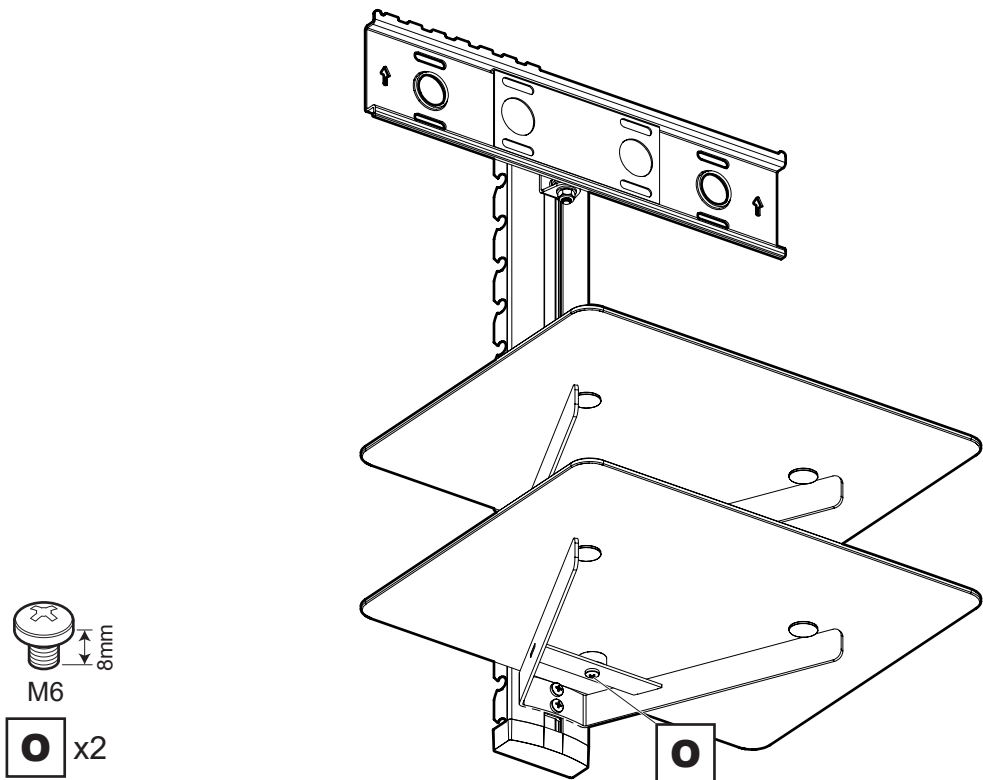
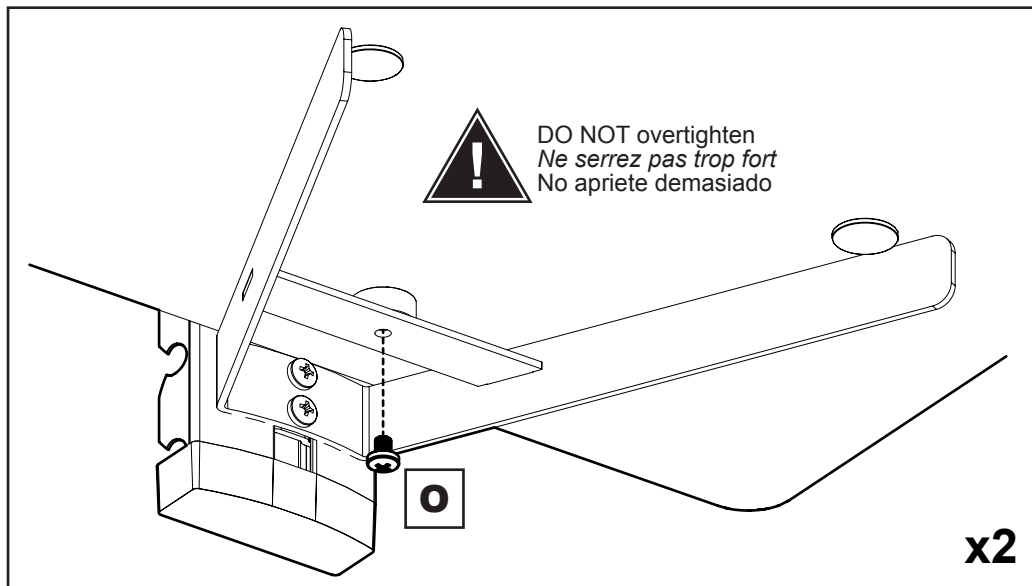

Attach the TV
Fixer la TV
Coloque la TV

11

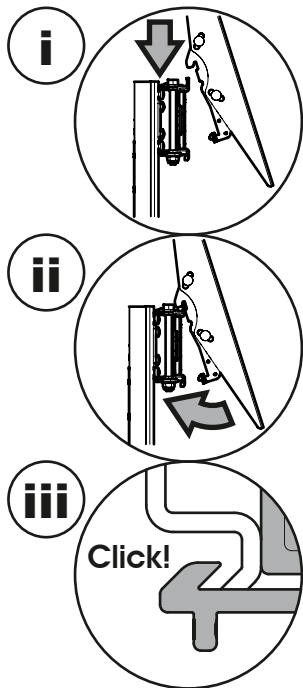
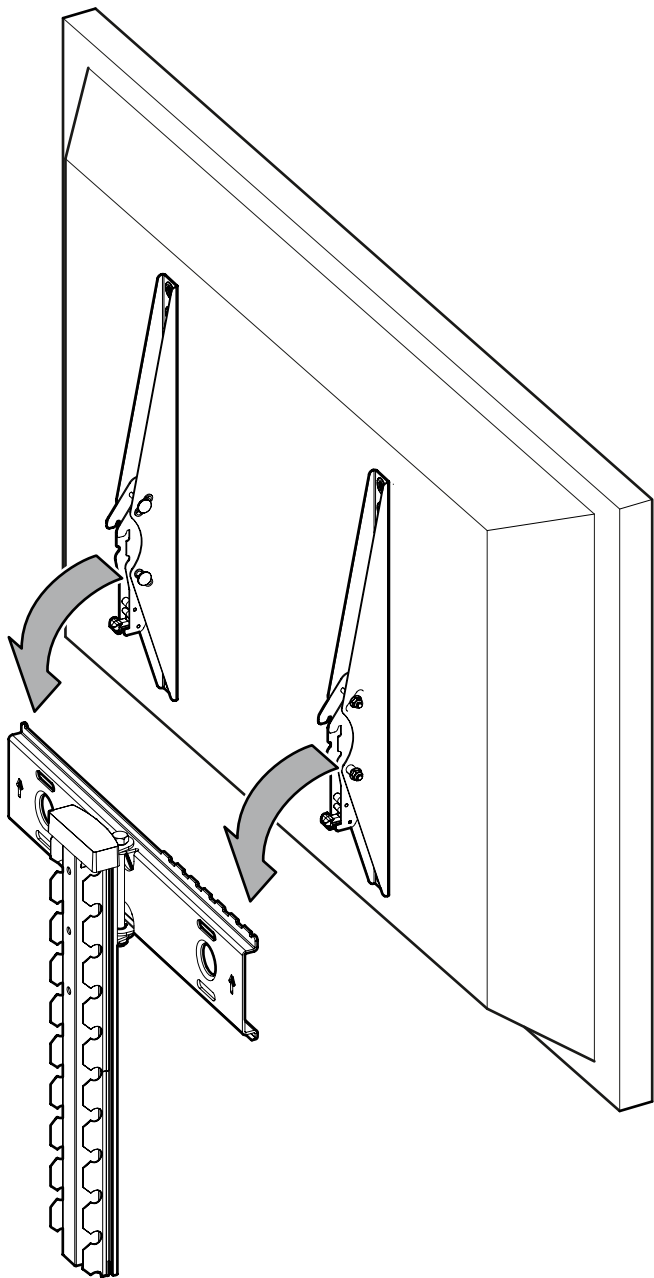

Optional
Optionnel
Opcional

Lock tilt
Vérouiller l'inclinaison
Cerradura de la función
de inclinación

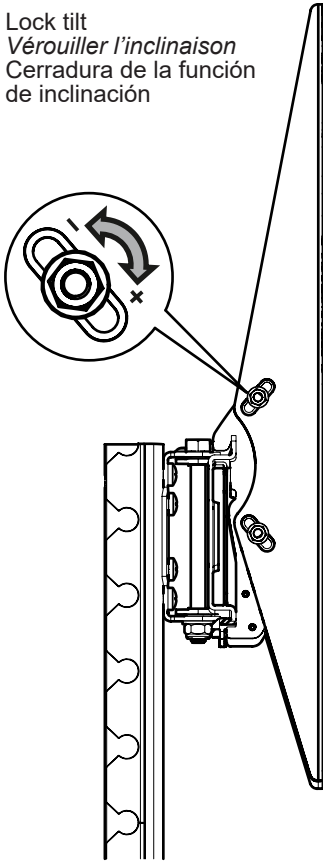

To remove TV
Pour enlever le téléviseur
Para quitar la TV

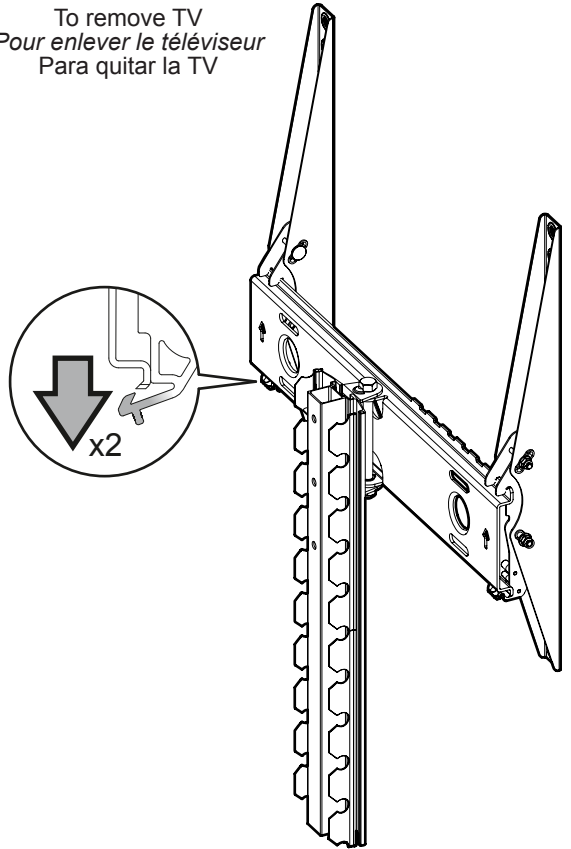

Adjustable
Ajustable
Ajustable

