

Read through **ALL** instructions before commencing installation.

If you have any questions about this product or issues with installation, contact the customer services helpline before returning this product to the store.



Lisez **TOUTES** les instructions avant de débiter l'installation.

Si vous avez des questions sur ce produit ou des problèmes d'installation, contactez l'assistance client avant de ramener le produit en magasin.



Lea **TODAS** las instrucciones antes de comenzar la instalación.

Si tiene alguna pregunta sobre el producto o problemas con la instalación, llame a la línea de servicio al consumidor antes de devolverlo.

CUSTOMER SERVICES HELPLINE NUMBER:

NUMÉRO DE L'ASSISTANCE CLIENT:

NUMERO DE SERVICIO DE ATENCION AL CLIENTE:

+44 (0) 333 320 0463 (UK)

1-800 667 0808 (USA)

Index
Index
Indice

1 Measure the TV fixing holes Width and Height
Mesurer la profondeur et la taille des trous de fixation
Mida los orificios de su TV, lo ancho y lo alto

2 Fitting the TV Brackets
Montage des supports TV
Fije los Brazos del Soportes a su TV

3 Assemble the Base
Assembler la base
Montar la base

4 Connecting the TV
Connecter le téléviseur
Conectando la TV

5 Cable management
Gestion des câblages
Manejo de Cable

Retain all packaging in case the product needs to be returned.

Contents may vary from photography / illustrations.

You will not need all these parts, so expect there to be some left over depending upon the specification of your TV.

This product is intended for indoor use only. Use of this product outdoors could lead to failure and personal injury.

Conserver tous les emballages au cas où ce produit devrait nous être renvoyé.

Les contenus peuvent varier de la photographie / illustrations.

Vous n'aurez pas besoin de toutes ces pièces, attendez-vous donc à ce qu'il reste des pièces selon les caractéristiques de votre téléviseur.

Ce produit est à utiliser à l'intérieur uniquement. Utiliser ce produit à l'extérieur causera des défaillances et de possibles accidents.

Conservar todos los embalajes en caso de que tenga que devolver este producto.

El contenido puede variar de la fotografía / ilustración.

No necesitará todas estas partes, espere que sobren algunas según las especificaciones de su TV.

Este producto está diseñado para el uso en el interior solamente. El uso de este producto en el exterior podría llevar al fracaso y lesiones personales.

Tools Recommended
Outils recommandés
Herramientas recomendadas

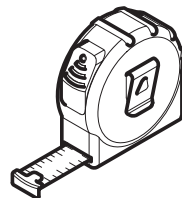
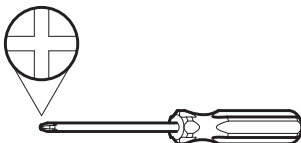

Boxed Parts
Pièces empaquetées
Piezas en la Caja

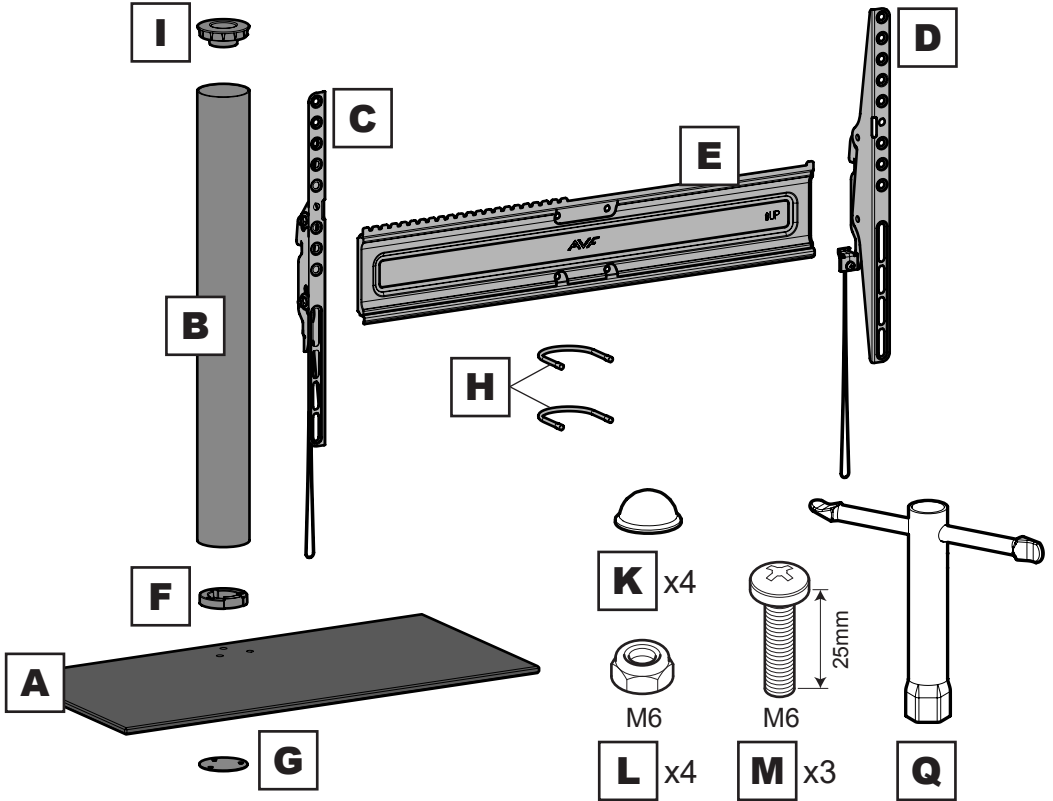

TV Screws, Reducers and Spacers
Vis TV, réducteurs et séparateurs
Tornillos, Reductores y Espaciadores para TV

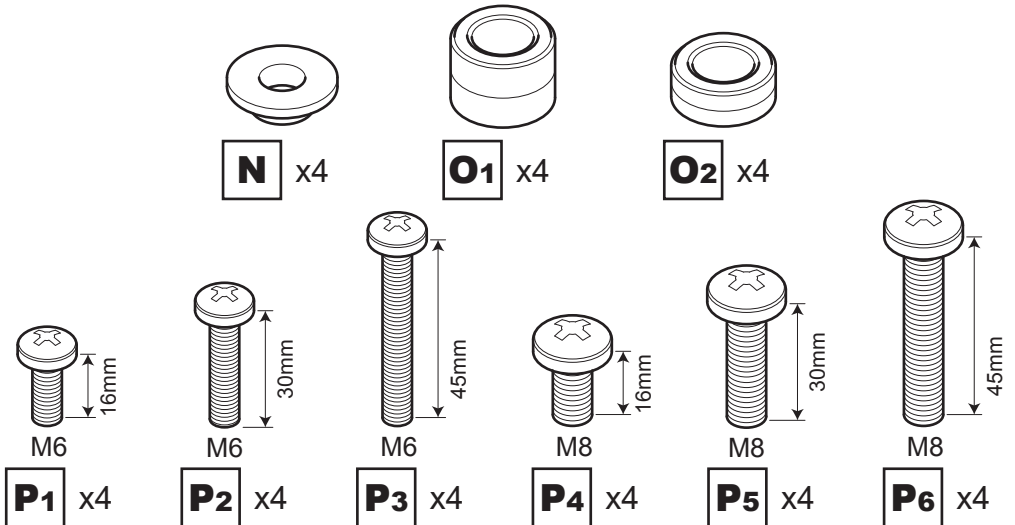

1

Measure the TV fixing holes Width and Height
 Mesurer la profondeur et la taille des trous de fixation
 Mida los orificios de su TV, lo ancho y lo alto

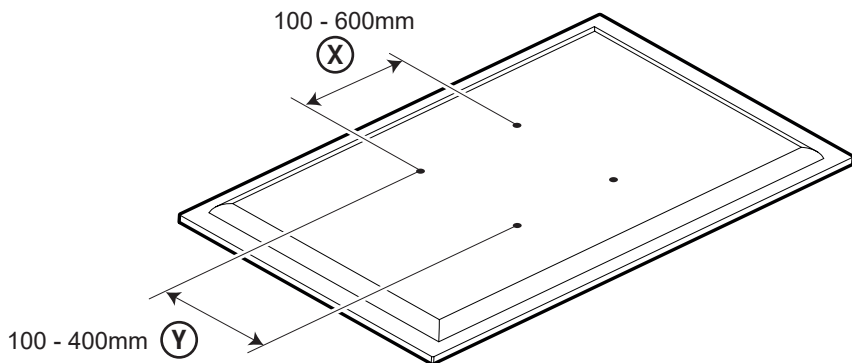

If width (X) is greater than 600mm or height (Y) greater than 400mm
 STOP installation now and contact the customer help line



*Si la largeur (X) est plus large que 600mm et la hauteur (Y) plus grande que 400mm,
 ARRÊTEZ l'installation immédiatement et contactez l'assistance client*

Si la anchura (X) es mayor que 600mm o la altura de (Y) es mayor que 400mm
 DETENGA la instalación inmediatamente y póngase en contacto con la línea de
 ayuda al cliente

You are provided with 2 diameters of TV fixing screws, **M6** and **M8**.
 Determine the screw diameter that fits and remember for step 2.

*2 diamètres de vis TV vous sont fournis, **M6** et **M8**.*

Déterminez le diamètre de la vis qui convient et mémorisez- le pour l'étape 2.

Se le proporciona con 2 diámetros de tornillos de fijación para su TV: **M6** y **M8**.
 Determine el diámetro del tornillo que le quede a su TV y recuérdelo para el paso 2.

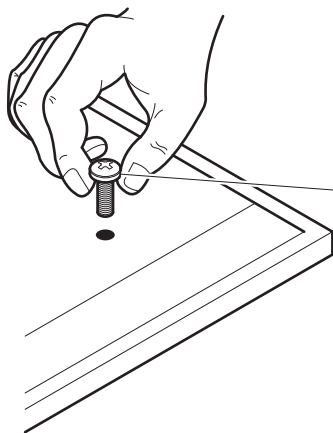

M6 = P1/P2/P3

M8 = P4/P5/P6

2

Fitting the TV Brackets Montage des supports TV Fije los Brazos del Soportes a su TV

No Spacers
Pas de séparateur
Sin espaciadores

For TVs with flat / unobstructed back
*Pour des téléviseurs aux dos
plats et non obstrués*
Para TVs con la parte posterior
plana / sin obstáculos

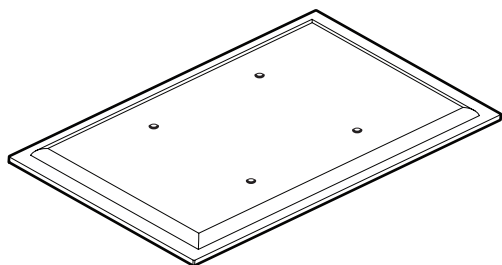

Spacers
Séparateurs
Espaciadores

01/02

For TVs with irregular / obstructed back
*Pour des téléviseurs aux dos
irréguliers et non obstrués*
Para TVs con la parte posterior
irregular / con obstáculos

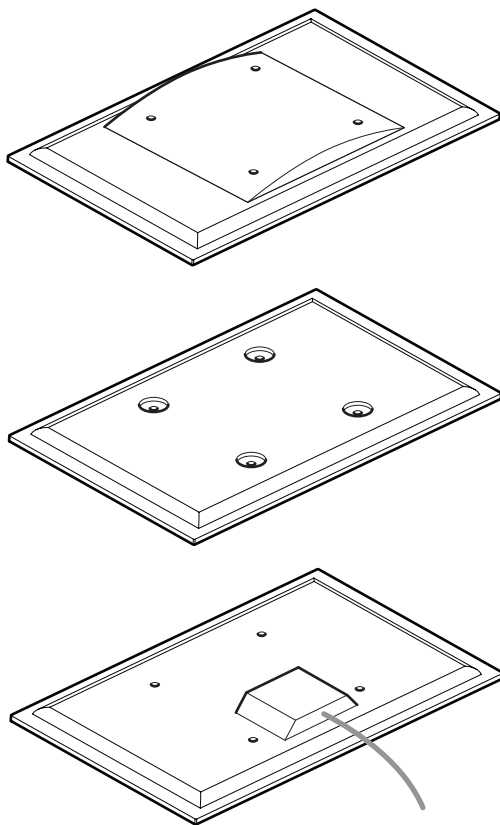

WARNING / AVERTISSEMENT / ADVERTENCIA

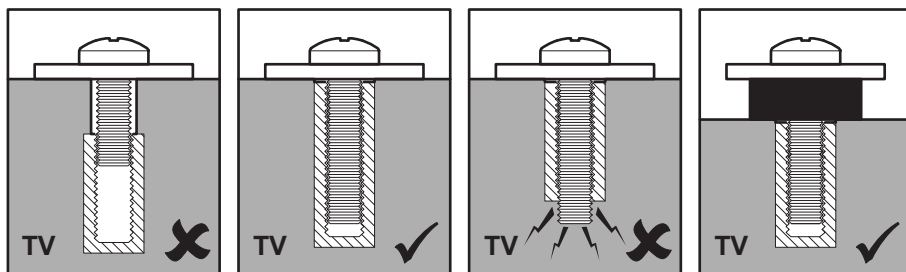

Attach the bracket to the back of your TV using suitable screw, reducer and spacer combinations.
Attachez l'applique au dos de votre téléviseur en utilisant une combinaison de vis, de séparateurs et de joints adaptés.

Coloque los soportes a la parte posterior de su TV usando la combinación adecuada de tornillo, reductor y espaciador.

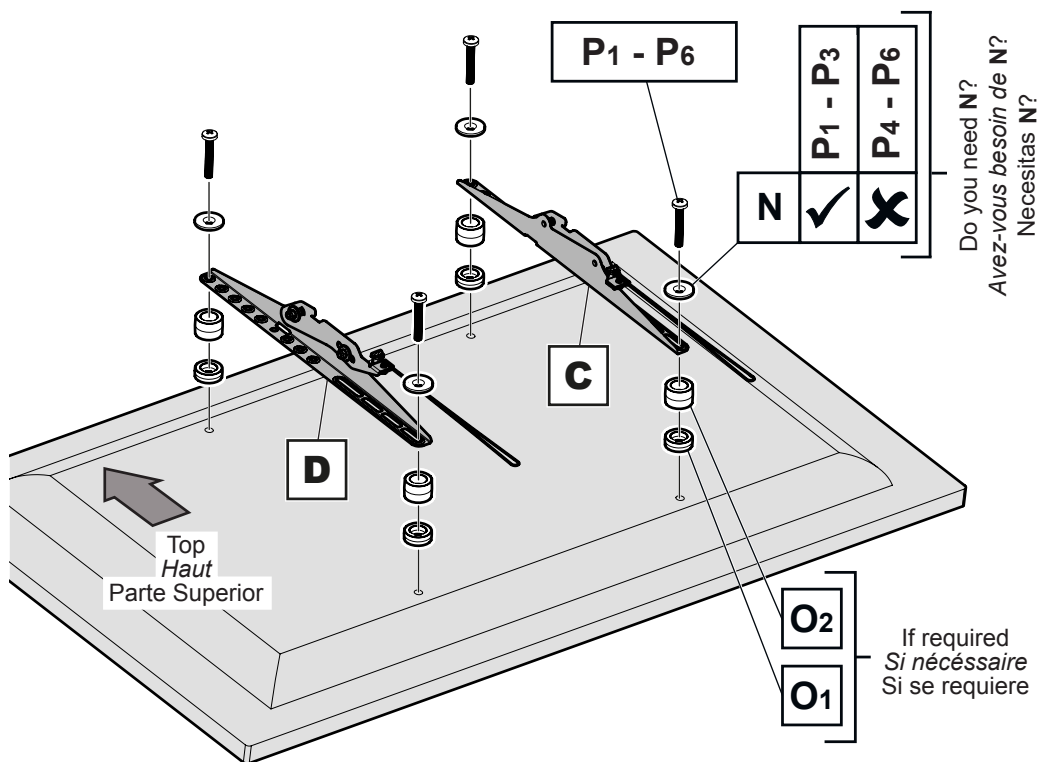

After completing step 2 you will have fittings left over, please keep for future reference.
Après avoir complété l'étape 2 il vous restera des pièces d'assemblage, conservez-les.
 Después de completar el paso 2 usted tendrá conexiones sobrantes, por favor guarde para futura referencia.

3 Assemble the Base
Assembler la base
Montar la base

Attach the feet to the bottom of the glass base
Attacher les pieds sur la partie inférieure de la base en verre
Fijar las patas en la parte inferior de la base de vidrio

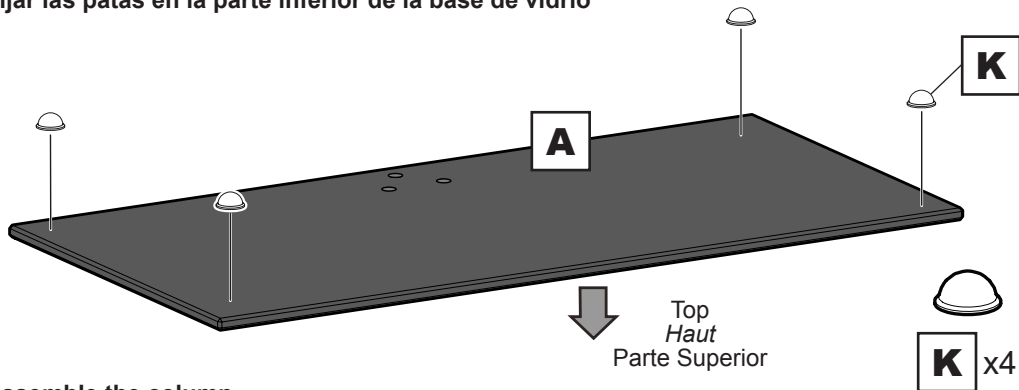

Assemble the column
Assembler la colonne
Montar la columna

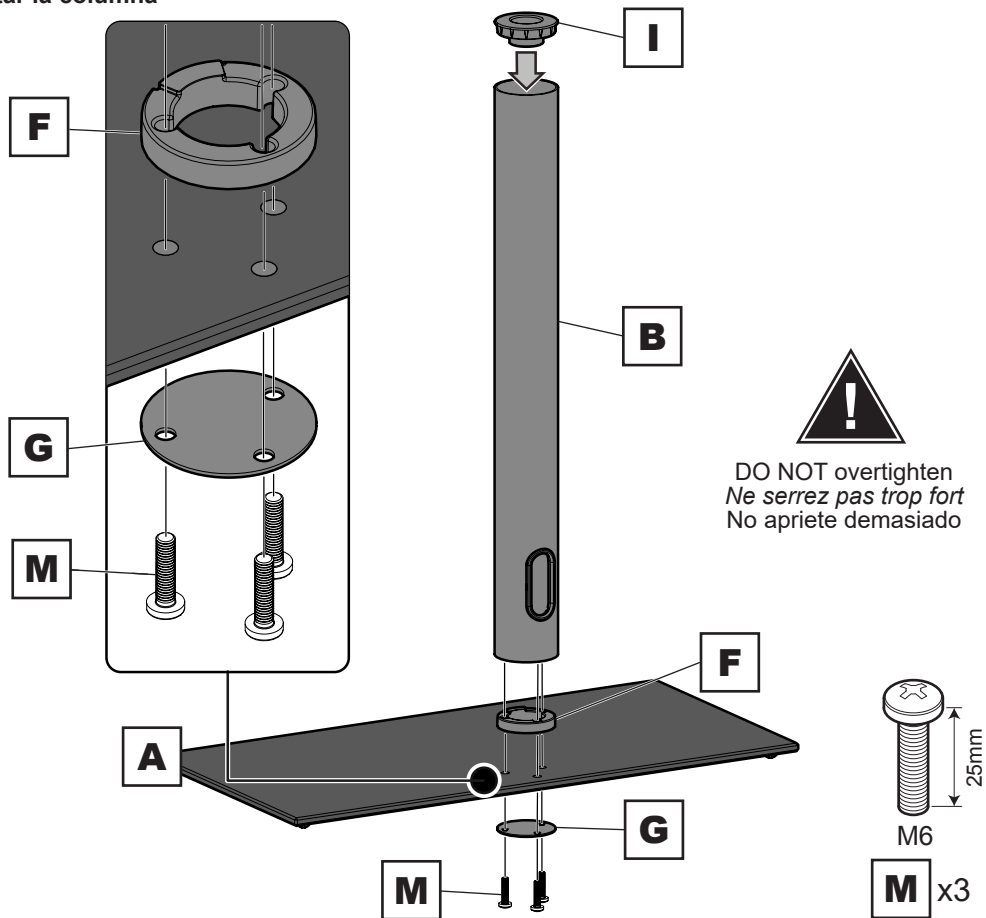

Attach the horizontal plate
Attacher la plaque horizontale
Fijar la placa horizontal

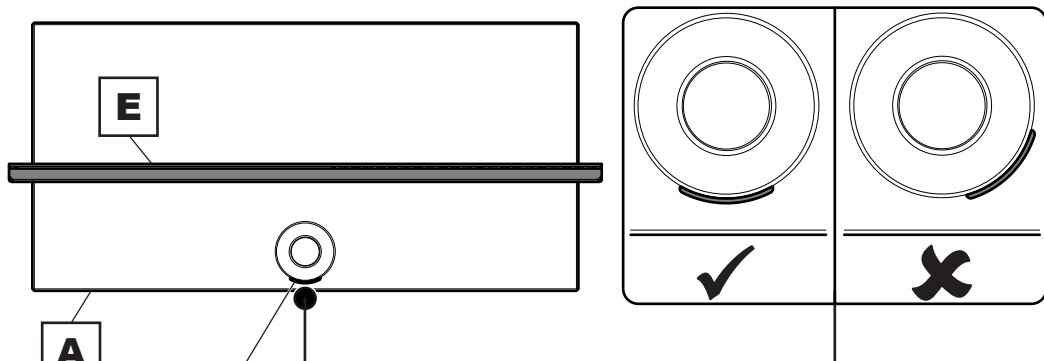

Cable Management Hole
Passe-câble
Agujero de gestión de cables



Ensure Cable Management Hole and Horizontal Plate **E** are parallel with the rear of the glass base **A** before fitting.
*Assurez-vous que le trou passe-câbles et la plaque horizontale **E** sont bien parallèles à l'arrière de la base en verre **A**, avant le montage.*
Asegúrese de que el agujero de gestión de cables y la placa horizontal **E** están paralelos con la parte trasera de la base de vidrio **A** antes de ajustarlo.



Set height as desired
Réglez la hauteur à votre convenance
Establecer la altura como se desee

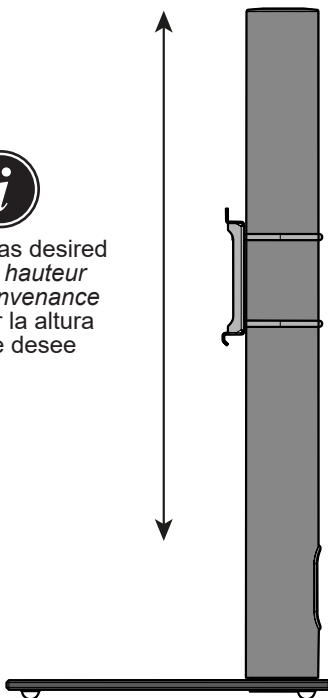

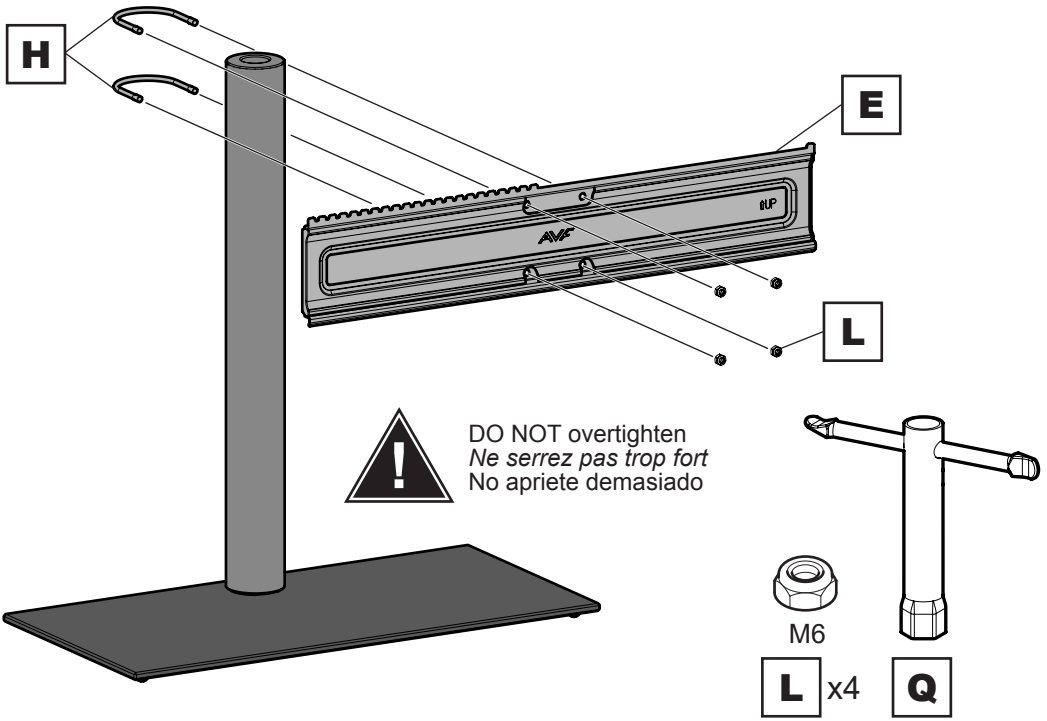

4

Connecting the TV
Connecter le téléviseur
 Conectando la TV

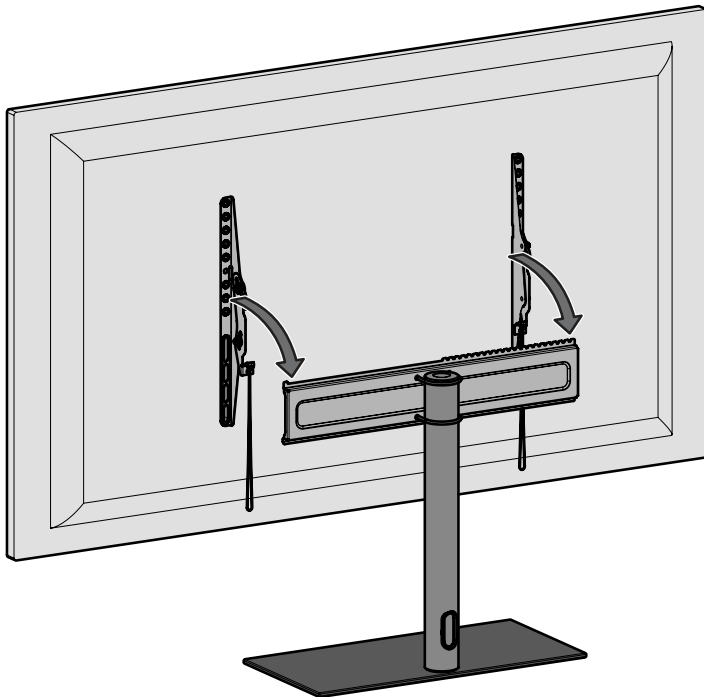

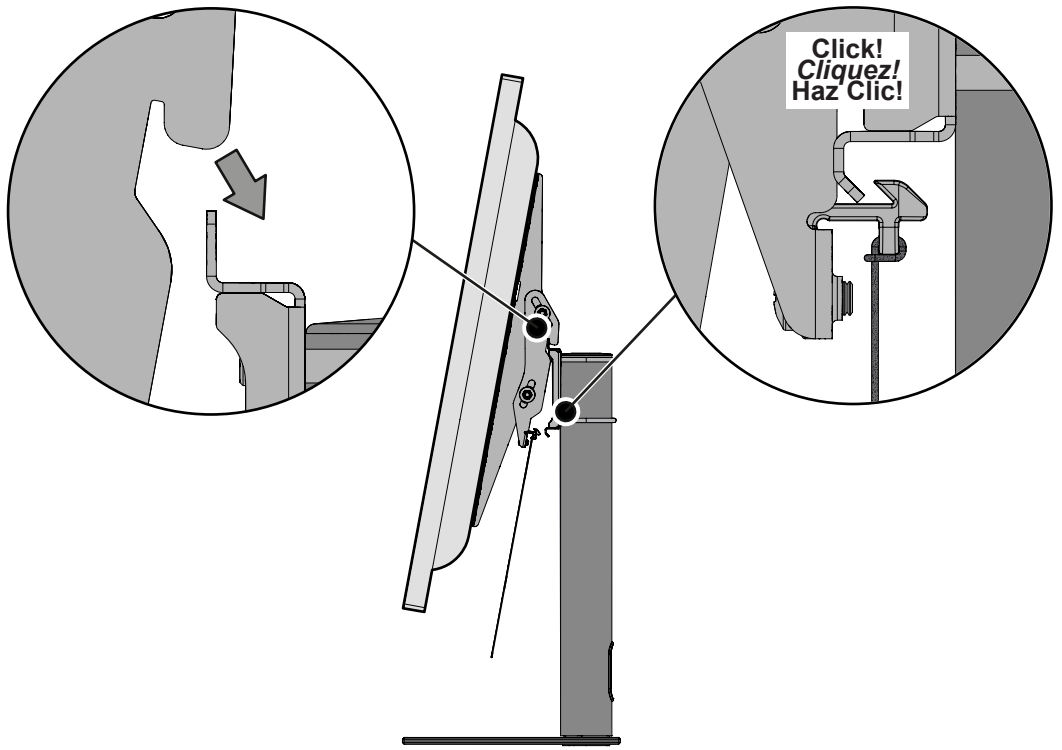

To Remove the TV
Pour enlever le téléviseur
Para quitar la TV

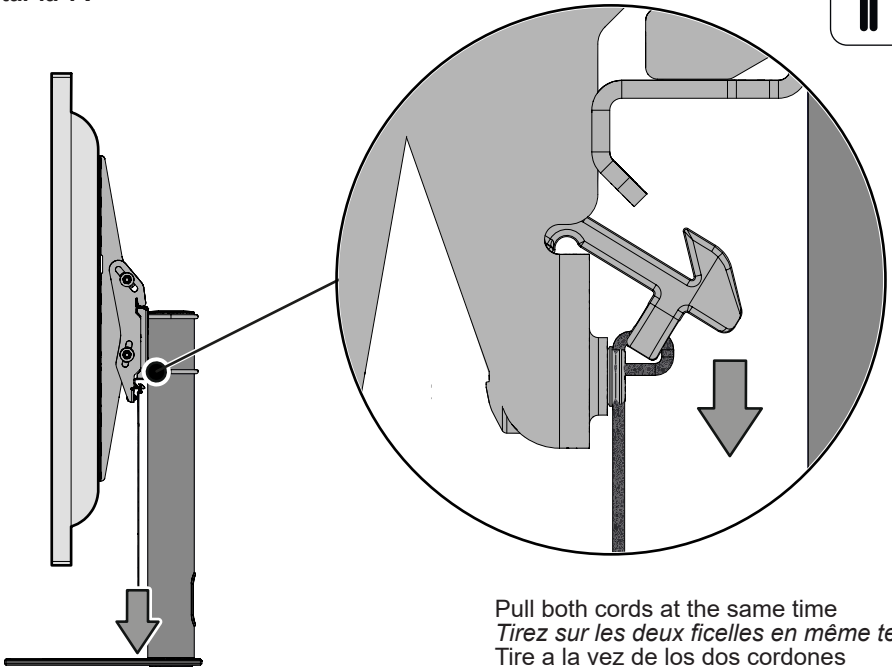

Pull both cords at the same time
Tirez sur les deux ficelles en même temps
Tire a la vez de los dos cordones

5

Cable management
Gestion des câblages
Manejo de Cable

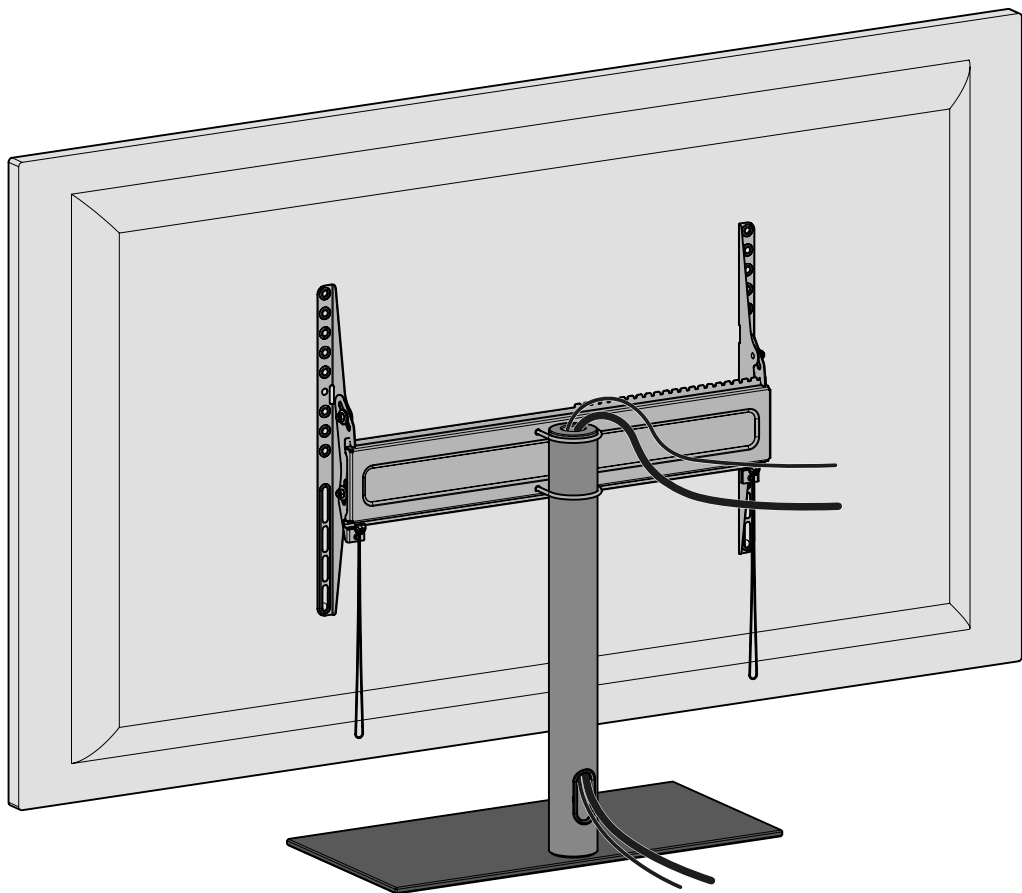

LIFETIME WARRANTY

AVF warrants that the product is free from defects in material and workmanship, as long as the product is owned by the original consumer purchaser. If, during the stated warranty of this product, it proves to be defective, AVF will remedy the defect by either repairing or replacing the defective part or, replacing the entire product. Proof of original purchase is required and should be retained.

AVF reserve the right to substitute replacement products to others of similar value and design (Usually in the event of discontinued product models).

AVF accept no responsibility for failures / loss which result from misuse, negligence, accident, improper assembly or installation or other causes beyond AVF's reasonable control and also excludes and will not pay any incidental and consequential damages.



PLEASE REVIEW ALL NOTES AND PRODUCT INSTRUCTIONS BEFORE COMMENCING THE INSTALLATION.

INSTALLATION: This product is sold as a home DIY product and as such, it is the responsibility of the installer to ensure that the product is correctly installed. AVF accept no responsibility if the product is incorrectly installed.

This product is intended for indoor use only. Use of this product outdoors could lead to failure and personal injury.

IF YOU ARE IN ANY DOUBT, CONSULT A QUALIFIED CONTRACTOR.

NOTES

WALLS: It is the responsibility of the installer to ensure that the wall is of a suitable standard and void of any services (eg gas, electricity, water etc). AVF accept no responsibility for any damage or loss caused by installing this product in a sub standard wall.

WALL FIXINGS: Wall fixings are supplied for wood, brick, solid masonry and also, for some specific products, fixings are supplied for fixing to plasterboard.

DO

- Retain all packaging in case the bracket needs to be returned.
- When fastening to wood studs, be sure to pre-drill holes into the wood stud.
- When fastening to brick or solid masonry, drill the holes in accordance with the instructions. Always remove drill dust from the hole before inserting the wall plug.
- Wall plug body must be fully inserted into the wall (ie fully into the brick).
- Lubricate the wall screws with soap to ease installation.
- Check the strength of the installation before fitting the TV.
- Periodically check strength of installation, signs of corrosion, damage or loose components.

DON'T

- Do not set in mortar joints.
- Do not over tighten screws.

TV HANGING

Must be carried out using the manufacturers threaded holes intended for this purpose. All variables of TV hanging screws are supplied within the product box (Because of the universal nature of this product, expect to have excess parts left over following your installation).

It is the responsibility of the installer to ensure the correct TV hanging screws are selected. If in doubt consult the TV manufacturer. AVF accept no responsibility for any damage caused by the use of the incorrect TV hanging screw or the use of incorrect fixing holes.