

**STOP**

Read through **ALL** instructions before commencing installation.

If you have any questions about this product or issues with installation, contact the customer services helpline before returning this product to the store.



This TV Wall Mount is intended for use with televisions weighing **Maximum 68kg (150lbs)**. Use with products heavier than maximum weight may result in instability causing possible injury.

**ALTO**

Lea **TODAS** las instrucciones antes de comenzar la instalación.

Si tiene alguna pregunta sobre el producto o problemas con la instalación, llame a la línea de servicio al consumidor antes de devolverlo.



Este soporte es para usar con televisores con un peso **máximo de 68kg (150lbs)**. El uso con productos más pesados que el peso máximo puede suponer inestabilidad y posibles lesiones.

CUSTOMER SERVICES HELPLINE NUMBER:  
NUMERO DE SERVICIO DE ATENCION AL CLIENTE:

**1-800 667 0808 (USA)**

## Assembly Overview Ensambladura General

Fit the TV Mounting Plate  
*Fije La Placa De Montaje De TV*

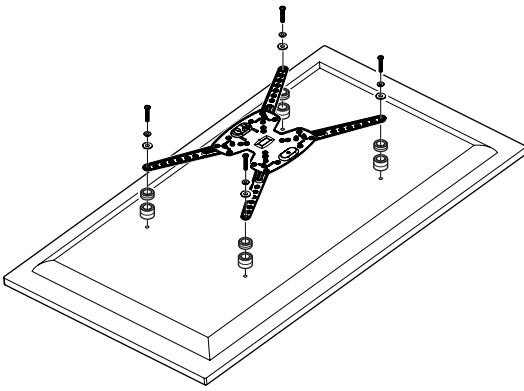

Determine your TV position  
*Determine la posición de su TV*



Fit the Wall Bracket  
*Fije el Soporte de Pared*

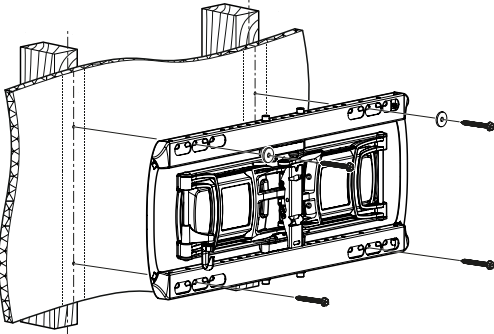

Connect the TV  
*Conecte la TV*

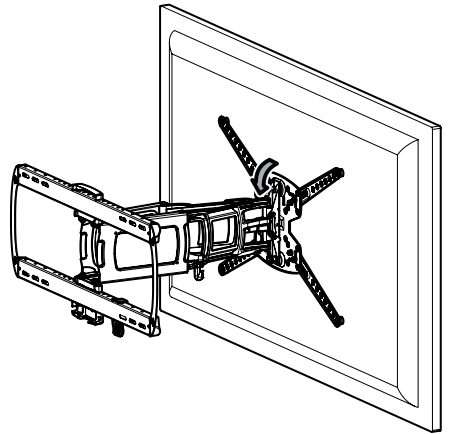

## Suitable Wall Types *Tipos adecuados de pared*

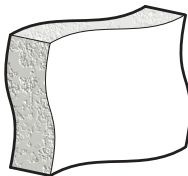

Solid Wall  
*Pared sólida*

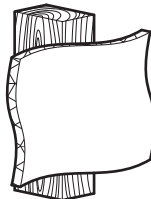

Wood Stud  
*Viga de madera*

## Index Índice

**1** Measure the TV fixing holes Width and Height  
*Mida los orificios de su TV, lo ancho y lo alto*

**2** Preparing the TV Mounting Plate  
*Preparando La Placa De Montaje De TV*

**3** Fitting the TV Mounting Plate  
*Fijando La Placa De Montaje De TV*

**4** Marking Wall for Drill Points  
*Marcar la Pared Para Punto de Taladro*

**5** Fitting the Wall Plate  
*Montaje de la placa para la pared*

**6** Lateral Shift (Optional)  
*Desplazamiento lateral (opcional)*

**7** Fitting the Wall Plate Covers  
*Montaje de las cubiertas de la placa para la pared*

**8** Connecting the TV  
*Conectando la TV*

**9** Cable management  
*Manejo de Cable*

**10** Lock Tilt (optional)  
*Ajuste de inclinación (opcional)*

**11** TV Levelling  
*Nivelación de TV*

Retain all packaging in case the product needs to be returned.

Contents may vary from photography/illustrations.

You will not need all these parts, so expect there to be some left over depending upon the specification of your TV.

This product is intended for indoor use only. Use of this product outdoors could lead to failure and personal injury.

It is the responsibility of the installer to ensure that the mounting wall is of a suitable standard and void of any services (eg gas, electricity, water etc).

AVF accept no responsibility for any damage or loss caused by installing this product in a substandard wall.

*Conserve todos los envasados en caso de que el soporte tenga que ser devuelto.*

*El contenido puede variar de la fotografía/ilustración.*

*No necesitará todas estas partes, espere que sobren algunas según las especificaciones de su TV.*

*Este producto está diseñado para el uso en el interior solamente. El uso de este producto en el exterior podría llevar al fracaso y lesiones personales.*

*Es la responsabilidad del instalador de asegurarse de que la pared de montaje es de un nivel adecuado y carece de todo los servicios (gas, electricidad, agua, etc.).*

*AVF no acepta ninguna responsabilidad por cualquier daño o pérdida causada por la instalación de este producto en una pared inadecuada.*

**Tools Recommended**  
**Herramientas recomendadas**

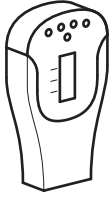

Stud Finder  
Detector de vigas  
de madera

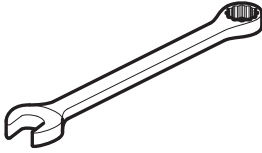

10mm  
13mm

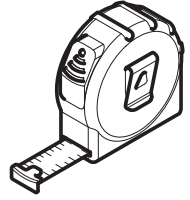
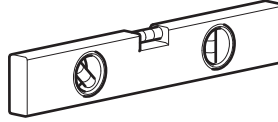

Ø5mm (13/64")  
Wood  
Madera



Ø12mm (15/32")  
Masonry  
Masonería

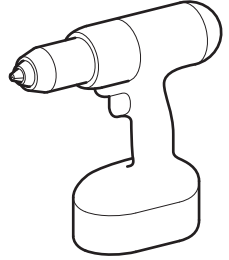

**Boxed Parts**  
**Piezas en la Caja**

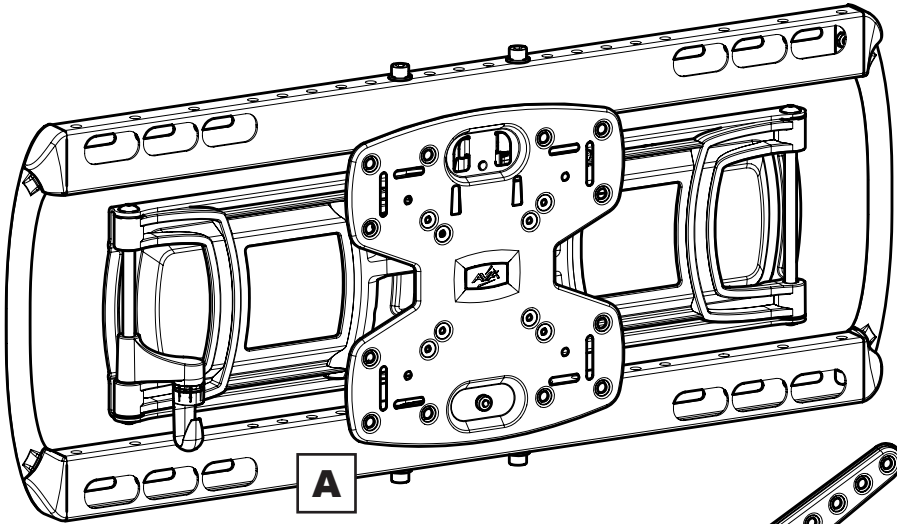

**C1**



**C2**



**C3**



**D**



x4

**B**

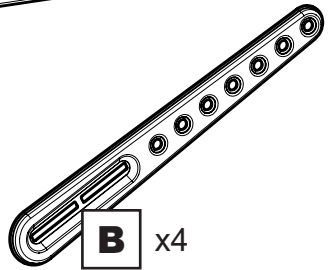

x4

**TV Screws, Reducers and Spacers**  
**Tornillos, Reductores y Espaciadores para TV**



**H1** x4



**H2** x4



**I1** x12



**I2** x4



**J1** x4

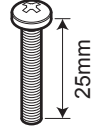

**J2** x4

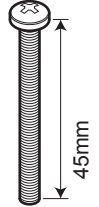

**J3** x4

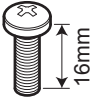

**J4** x4

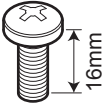

**J5** x4

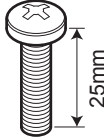

**J6** x4

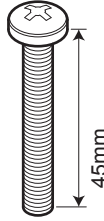

**J7** x4

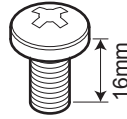

**J8** x4

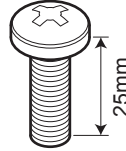

**J9** x4

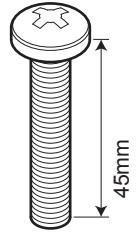

**J10** x4



**WT**

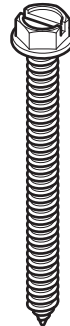

**K** x6

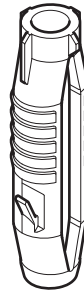

**L** x6



**M** x2



**E** x8



**F** x8



**G** x16

# 1 Measure the TV fixing holes Width and Height *Mida los orificios de su TV, lo ancho y lo alto*

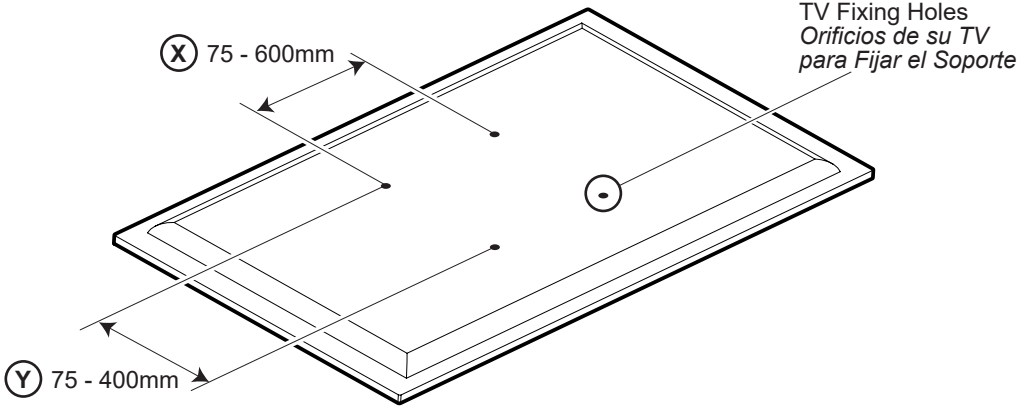

If width ⓧ is greater than 600mm or height Ⓨ greater than 400mm  
STOP installation now and contact the customer help line

*Si la anchura ⓧ es mayor que 600mm o la altura de Ⓨ es mayor que 400mm  
DETENGA la instalación inmediatamente y póngase en contacto con la línea de ayuda al cliente*

You are provided with 4 diameters of TV fixing screws, **M4**, **M5**, **M6** and **M8**.  
Determine the screw diameter that fits and remember for step 3.

*Se le proporciona con 4 diámetros de tornillos de fijación para su TV, **M4**, **M5**, **M6** et **M8**.  
Determine el diámetro del tornillo que le quede a su TV y recuérdelo para el paso 3.*

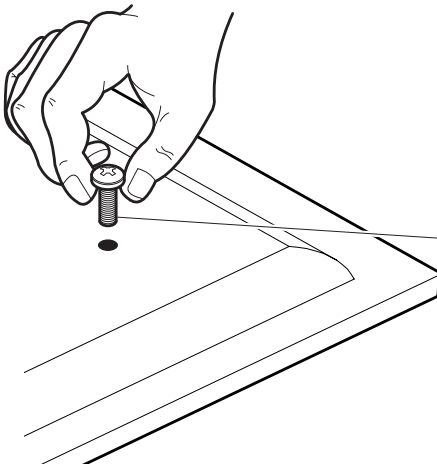

<b>M4</b> =	<b>J1/J2/J3</b>
<b>M5</b> =	<b>J4</b>
<b>M6</b> =	<b>J5/J6/J7</b>
<b>M8</b> =	<b>J8/J9/J10</b>

After completing step 3 you will have fittings left over, please keep for future reference.  
*Después de completar el paso 3 usted tendrá conexiones sobrantes, por favor guarde para futura referencia.*

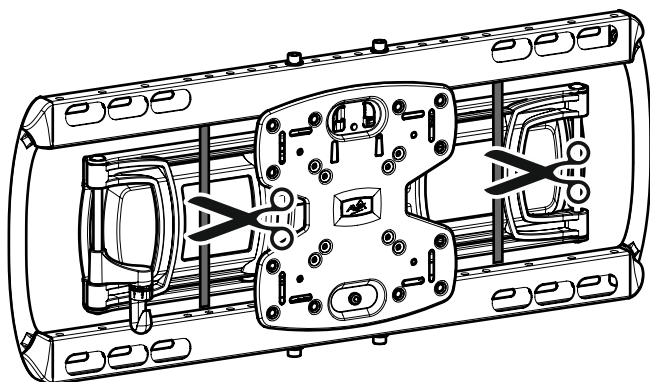

Before you can attach the TV mounting plate to your TV you need to remove the plate from your wall mount.

Antes de fijar la placa de montaje de TV a su TV, debe extraer la placa del montaje a la pared.

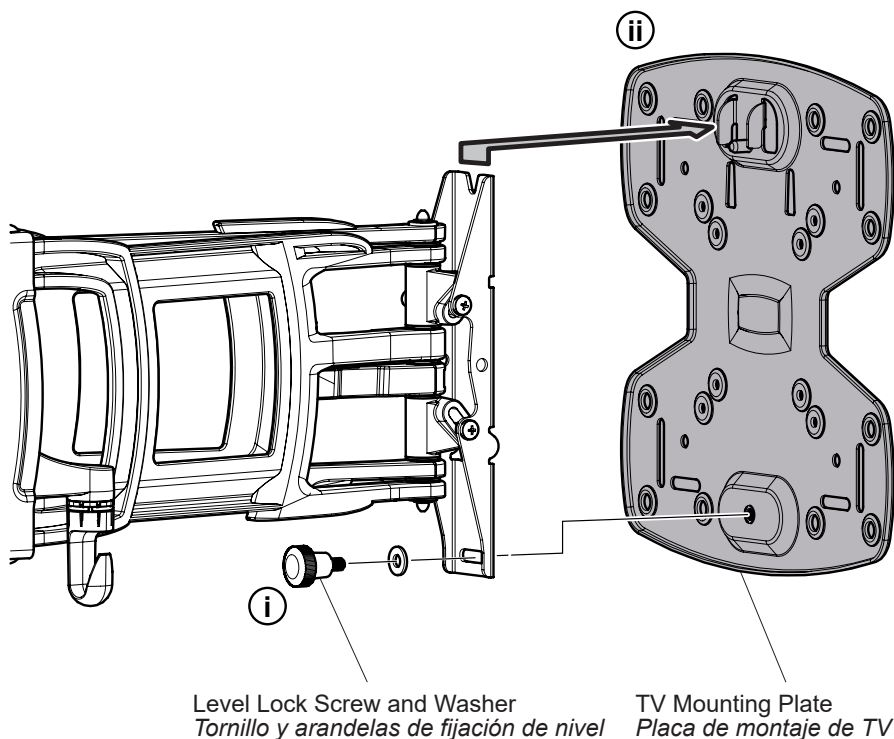

**i** Remove the Level Lock Screw and Washer and safely keep for step 8.  
*Extraiga el tornillo y las arandelas de fijación de nivel y consérvelos para el paso 8.*

**ii** Remove the TV Mounting Plate.  
*Extraiga la placa de montaje de TV.*

Use the option that fits your TV  
*Utilice la opción que mejor se adapte a su TV*

**OPTION 1 / OPCIÓN 1**

- (X) 75mm x (Y) 75mm
- (X) 100mm x (Y) 100mm
- (X) 100mm x (Y) 200mm
- (X) 200mm x (Y) 100mm
- (X) 200mm x (Y) 200mm

**OPTION 2 / OPCIÓN 2**

- (X) 300mm x (Y) 100mm
- (X) 300mm x (Y) 200mm
- (X) 300mm x (Y) 300mm
- (X) 400mm x (Y) 100mm
- (X) 400mm x (Y) 200mm
- (X) 400mm x (Y) 300mm
- (X) 400mm x (Y) 400mm
- (X) 75-400mm x (Y) 75-400mm
- (X) 600mm x (Y) 100mm
- (X) 600mm x (Y) 200mm
- (X) 600mm x (Y) 300mm
- (X) 600mm x (Y) 400mm
- (X) 400-600mm x (Y) 75-400mm
- (X) 630mm x (Y) 310mm

If in any doubt please call the customer help line.  
*Si tiene alguna pregunta, póngase en contacto con atención al cliente.*

**OPTION 1 / OPCIÓN 1**

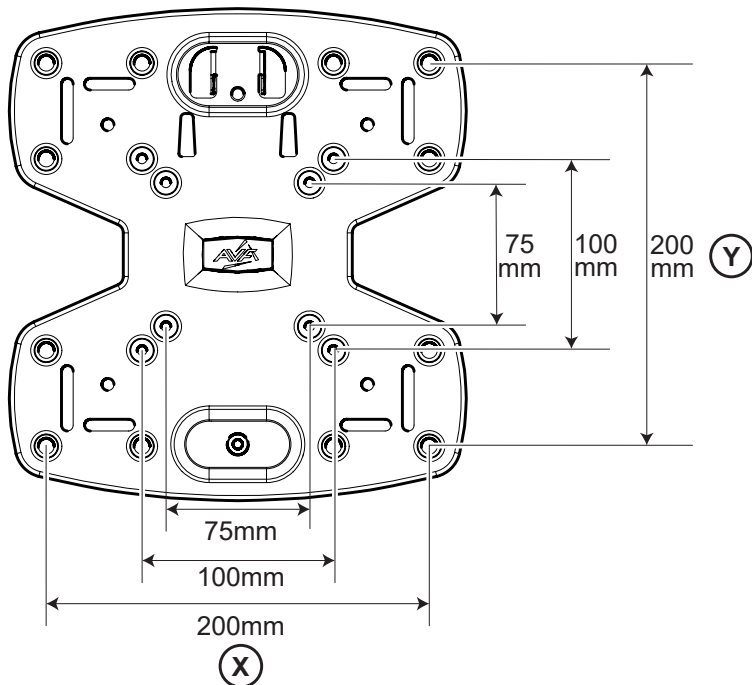

If your TV fixing holes match any of the sizes shown above you will not need to use any adaptors. Please go to step 3.

*Si los agujeros de fijación de tu TV coinciden con cualquiera de los tamaños mostrados encima, no tendrás que usar ningún adaptador. Por favor, ve al paso 3.*



**OPTION 2 / OPCIÓN 2**



When attaching adaptors **B** you must always use **HOLES x4** and either of the **SLOTS**.  
 Para colocar adaptadores **B** deberá siempre utilizar **ORIFICIOS x4** y alguna de las **RANURAS**.

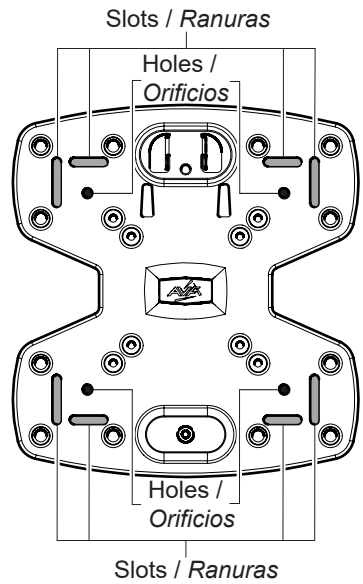

Example shown is 600 x 400 fixings.  
 El ejemplo se muestra con fijaciones de 600mm x 400mm.

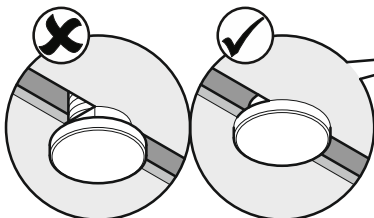
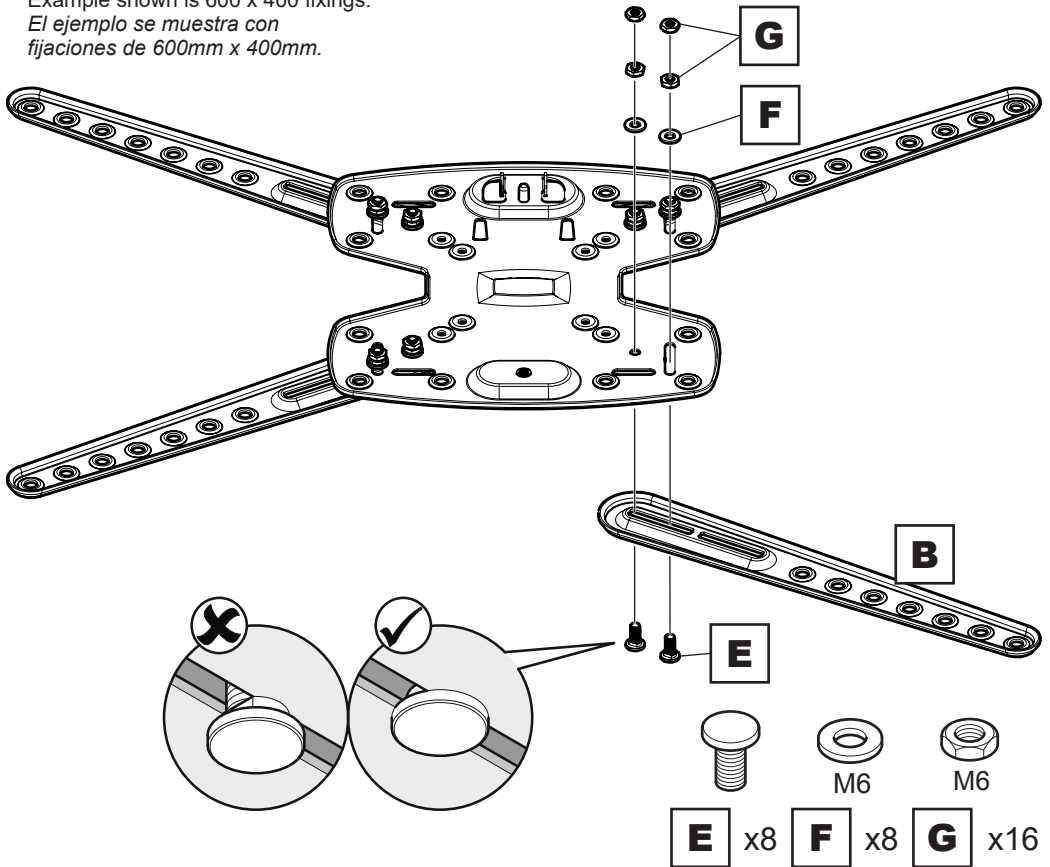

- Holes / Orificios
- Slots / Ranuras

Adaptors **B** can be fixed in different positions in the slots on the plate to match your TV fixing holes. *Los adaptadores **B** pueden fijarse en diferentes posiciones en las ranuras de la placa para que coincidan con los orificios de fijación de su televisor.*

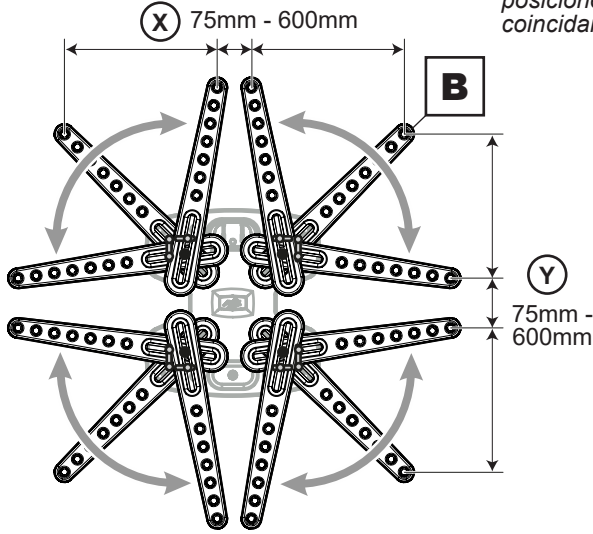

Below are some common examples of how the adaptors can be positioned to match the fixing holes on your TV. *A continuación, algunos ejemplos comunes sobre cómo posicionar los adaptadores de manera que concuerden con los orificios de fijación en su TV.*

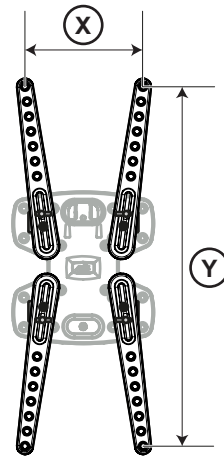
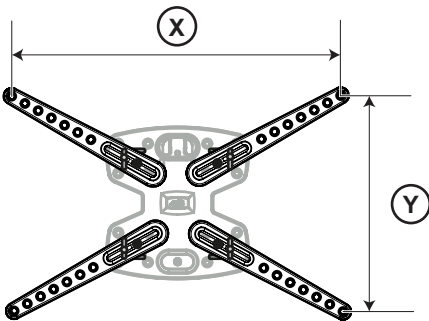
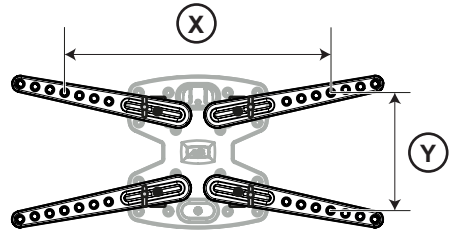
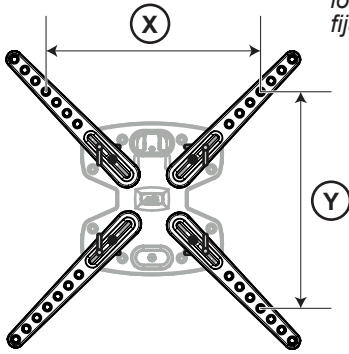

# 3

## Fitting the TV Mounting Plate Fijando La Placa De Montaje De TV

### No Spacers Sin espaciadores

For TVs with flat / unobstructed back  
Para TVs con la parte posterior  
plana / sin obstáculos

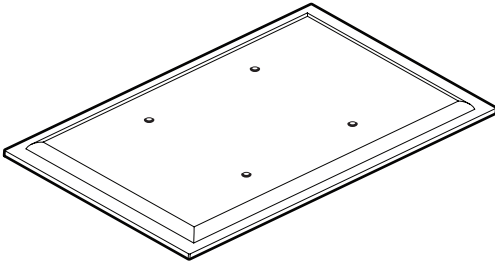

### Spacers Espaciadores

1 1/2

For TVs with irregular / obstructed back  
Para TVs con la parte posterior  
irregular / con obstáculos

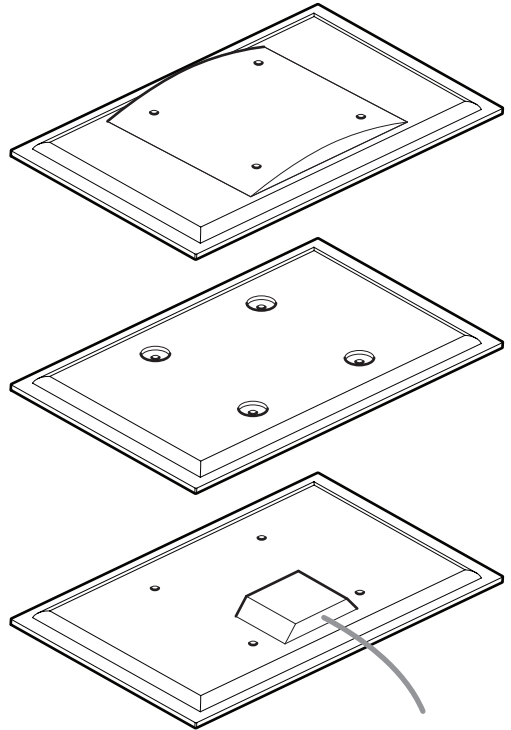

### WARNING / ADVERTENCIA

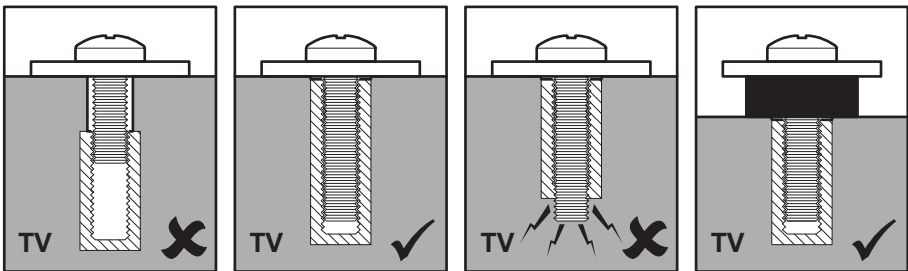

If your TV has an irregular/obstructed back or if you have any issues fitting to the back of your TV with the supplied screws, please call the customer services helpline.

Si la parte posterior de su TV es irregular o está obstruida o si tiene algún problema para fijar la parte posterior de su TV con los tornillos suministrados, comuníquese con la línea de asistencia al cliente.

Before you fully tighten the TV mounting plate please check that the mounting plate holes line up with the fixing holes on the back of your TV.  
*Antes de fijar completamente la placa de montaje de TV verifique que los orificios de la placa de montaje coincidan con los orificios en la parte posterior de su TV.*

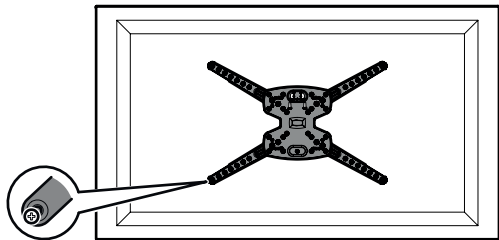

Holes do not line up and small adjustment is required before you fully tighten  
*Los orificios no coinciden y es necesario hacer un pequeño ajuste antes de fijar completamente*

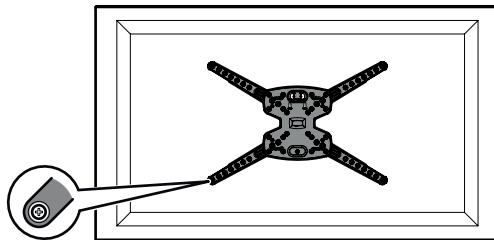

Holes line up and no adjustment is required before you fully tighten  
*Los orificios coinciden y no es necesario hacer ningún ajuste antes de fijar completamente*

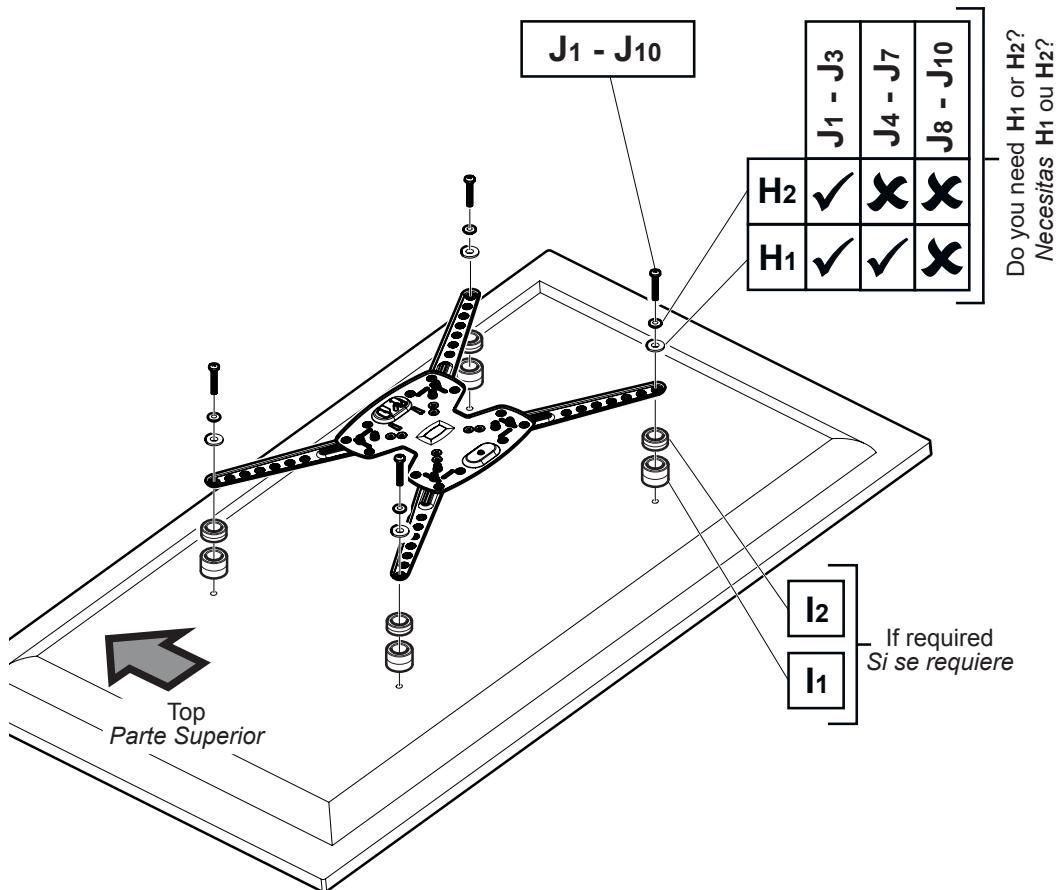

Attach the bracket to the back of your TV using suitable screw, reducer and spacer combinations.  
*Coloque los soportes a la parte posterior de su TV usando la combinación adecuada de tornillo, reductor y espaciador.*

# 4

## Marking Wall for Drill Points *Marcar la Pared Para Punto de Taladro*



For this step you will need your Wall Marking Template **WT**.  
*Para este paso necesitará su plantilla de marcado de pared WT.*



To determine the exact position for your drill points use the Height Calculator app. Follow the link to the app shown on your Wall Marking Template.

*Para determinar la posición exacta de sus puntos de perforación, use la aplicación Plantilla para el marcado fácil en la pared (Height Calculator). Siga el enlace a la aplicación que se muestra en su plantilla de marcado de pared.*

Before marking any drill points you will need to determine the wall type that you have, either **Solid Wall** or **Wood Stud Wall**. Ensure the drilling area is free from mains services (Gas / Electric / Water).

If fixing to a solid wall it is recommended that you place the drilling template so that the Wall Bracket Centre line is where you want the centre of your TV to be. If you need to avoid services embedded in the wall then you may need to laterally shift the arms on the wall bracket a small amount. See Lateral Shift Option.

If fixing to a wood stud wall you must place the drilling template so that the drilling holes are over two wood studs. If you want the centre of your TV in a different position to the Wall Bracket Centre Line you can laterally shift the arms on the wall bracket to ensure your TV is in the desired position. See Lateral Shift Option.

*Antes de marcar los puntos a perforar, deberá determinar el tipo de pared que tiene, que puede ser sólida o de estructura de madera. Verifique que por el área a perforar no pasen líneas de servicios (gas, electricidad, agua).*

*Si perforará sobre una pared sólida, se recomienda que coloque la plantilla de perforación de manera que la línea central del soporte de pared se encuentre en la parte central donde desea instalar su TV. Si pasan líneas de servicio por esa pared, deberá desplazar de forma lateral los brazos del soporte de pared levemente. Consulte la opción de instalación con desplazamiento lateral.*

*Si la instalación es sobre una pared con estructura de madera, debe colocar la plantilla de perforación de manera que los orificios de perforación queden sobre dos montantes de madera. Si desea que el centro de su TV quede en una posición diferente a la línea central del soporte de pared, puede desplazar lateralmente los brazos del soporte de pared para que su TV quede en la posición deseada. Consulte la opción de instalación con desplazamiento lateral.*

Before you drill make sure you are happy with the position and ensure template is level.

*Antes de comenzar a perforar, compruebe que la ubicación sea de su agrado y que la plantilla esté nivelada.*

# 5

## Fitting the Wall Plate Montaje de la placa para la pared

### Solid Wall / Pared sólida

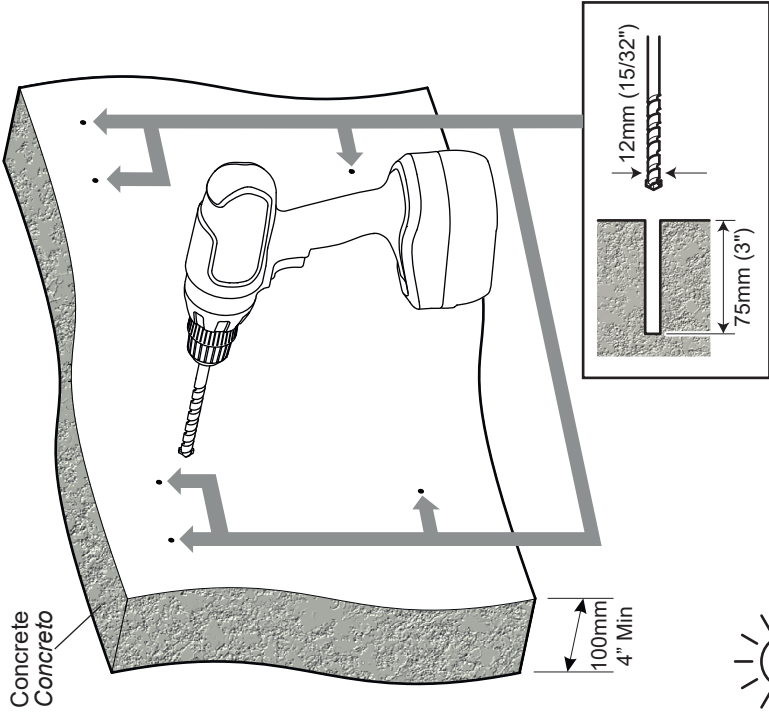

Remove Dust from Hole.  
Elimine el polvo del agujero



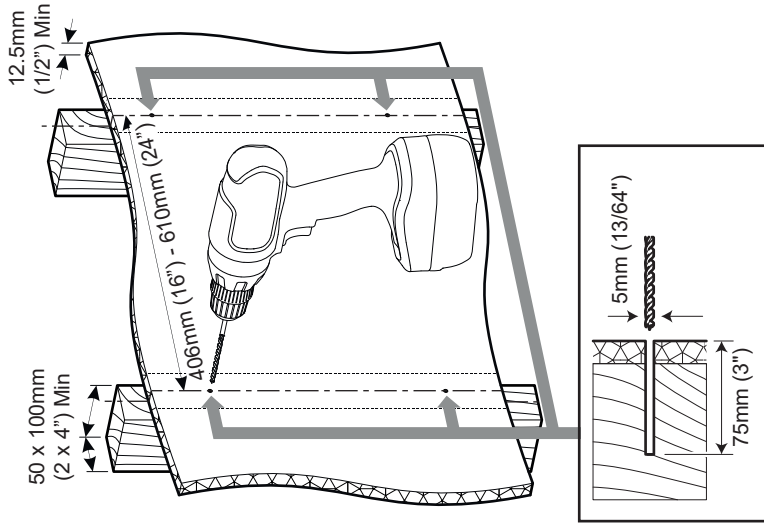

### Wood Stud / Viga de madera



Ensure you drill in the centre of the wood stud  
Asegúrese de perforar en el centro del montante de madera

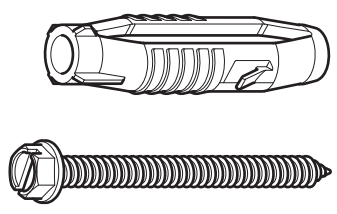
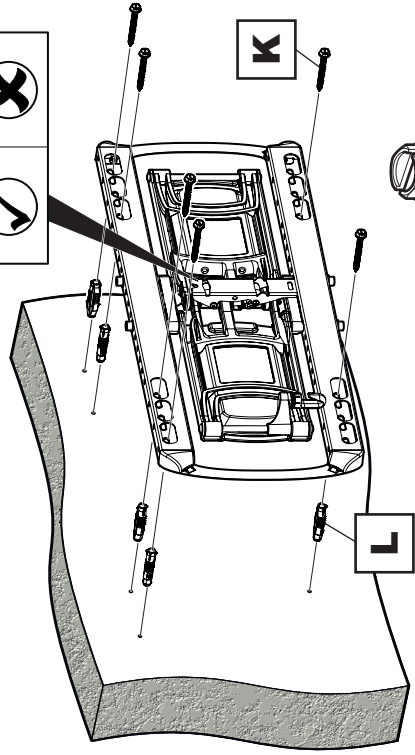
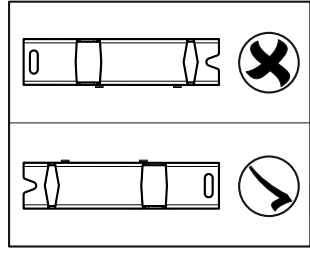
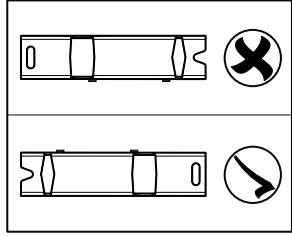



 Lubricate screw thread with soap  
*Lubrique la rosca del tornillo con jabón*

DO NOT overtighten screws.  
 Tighten screws by hand only.  
**NO sobre apriete los tornillos.**  
*Apriete los tornillos sólo a mano.*

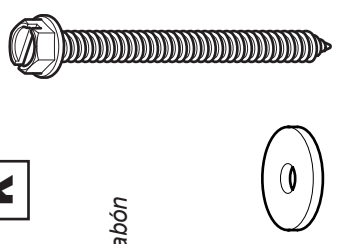
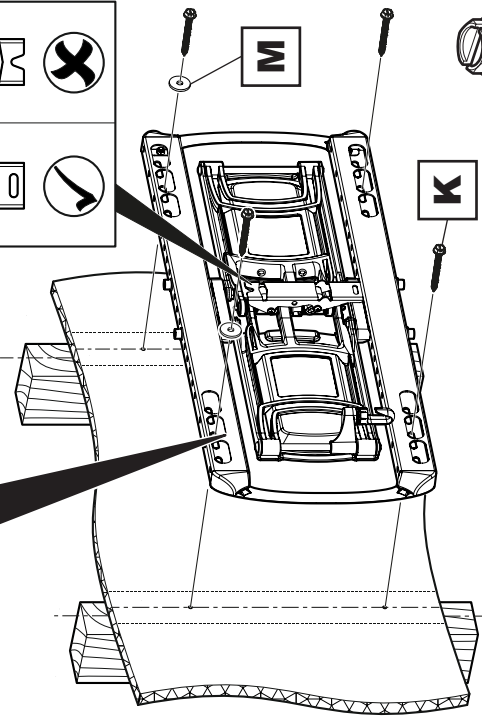
Lubricate screw thread with soap  
*Lubrique la rosca del tornillo con jabón*

DO NOT overtighten screws.  
 Tighten screws by hand only.  
**NO sobre apriete los tornillos.**  
*Apriete los tornillos sólo a mano.*

DO NOT use wall plugs in a wood stud wall.  
*En una pared de madera NO use tapones o plugs de pared.*



# 6

## Lateral Shift (Optional) *Desplazamiento lateral (opcional)*

The position you have chosen for your TV might not be central between the wood studs, or you may have to avoid services in the wall. In this case you can laterally shift the arms of the bracket so the TV is exactly where you want it.

*La posición que eligió para su TV quizás no quede centrada entre los montantes de madera o quizás deba evitar interferir con los servicios en la pared. En ese caso, puede desplazar lateralmente los brazos del soporte para que su TV quede exactamente donde desea.*

### Example of Lateral Shift *Ejemplo de desplazamiento lateral*

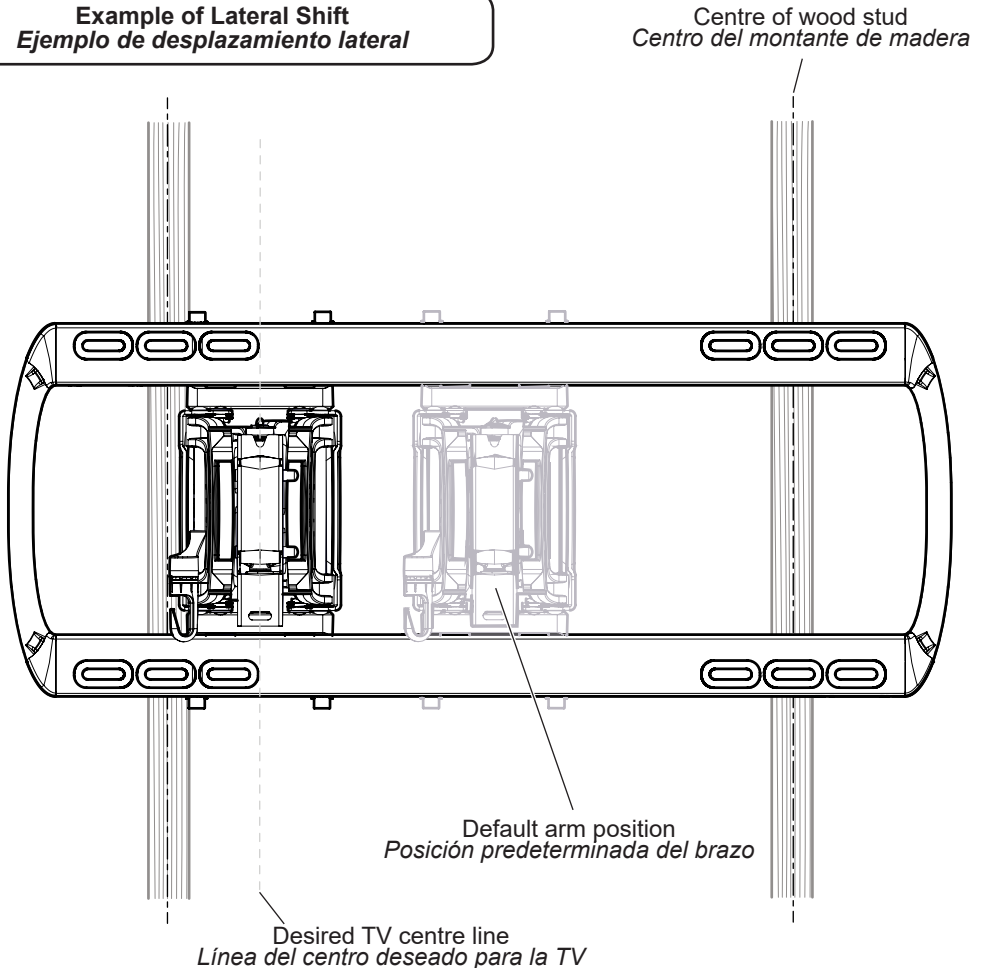



**Lateral Shift Procedure**  
**Procedimiento de desplazamiento lateral**

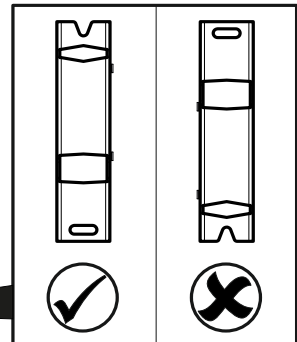
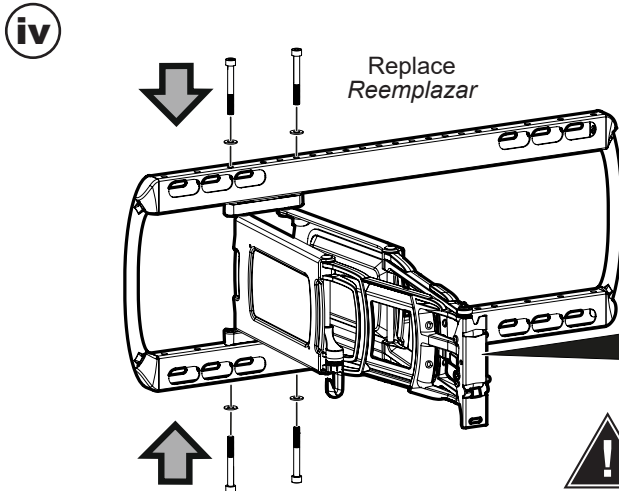
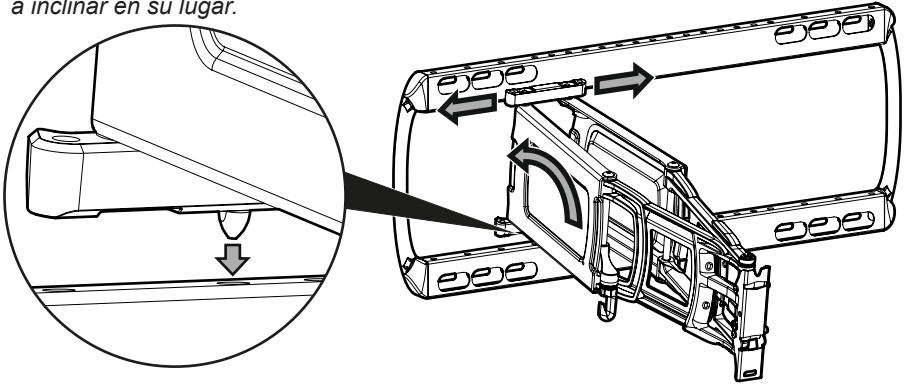
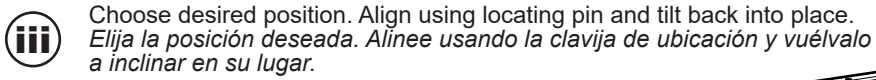
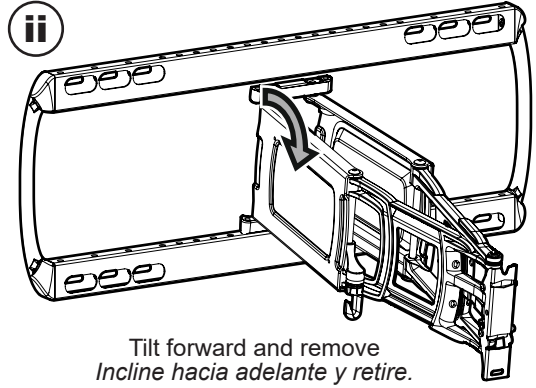
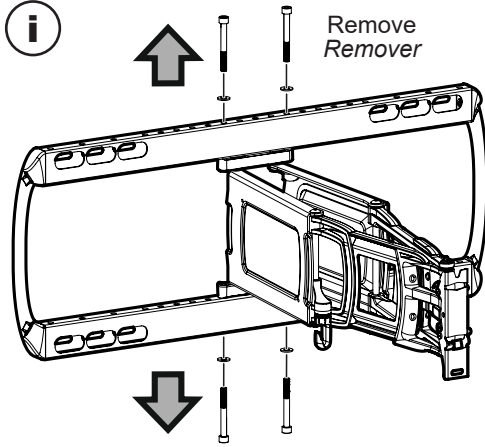

**DO NOT** overtighten  
*No apriete demasiado*

## 7 Fitting the Wall Plate Covers Montaje de las cubiertas de la placa para la pared

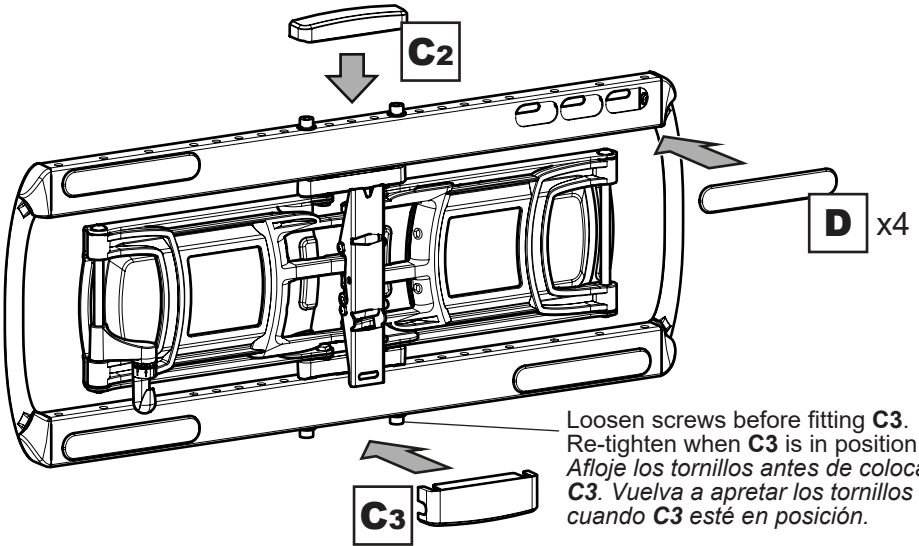

Loosen screws before fitting **C3**.  
Re-tighten when **C3** is in position.  
Afloje los tornillos antes de colocar **C3**.  
Vuelva a apretar los tornillos cuando **C3** esté en posición.

## 8 Connecting the TV Conectando la TV

Attaching and Locking  
Sujetando y Asegurando

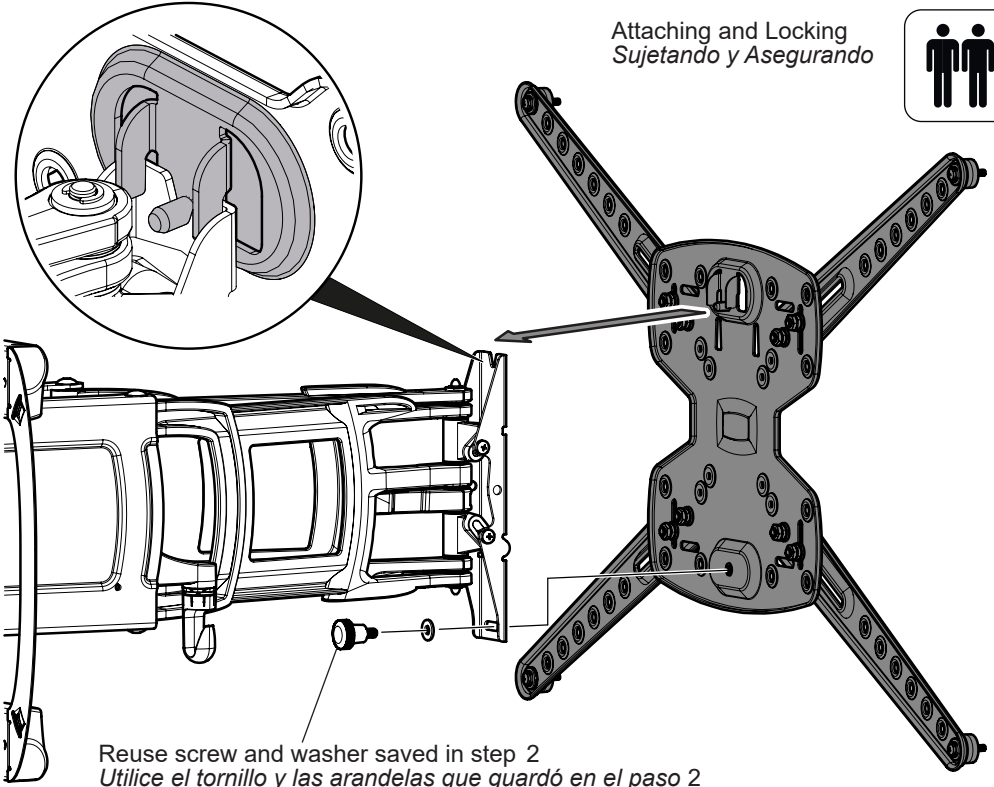

Reuse screw and washer saved in step 2  
Utilice el tornillo y las arandelas que guardó en el paso 2

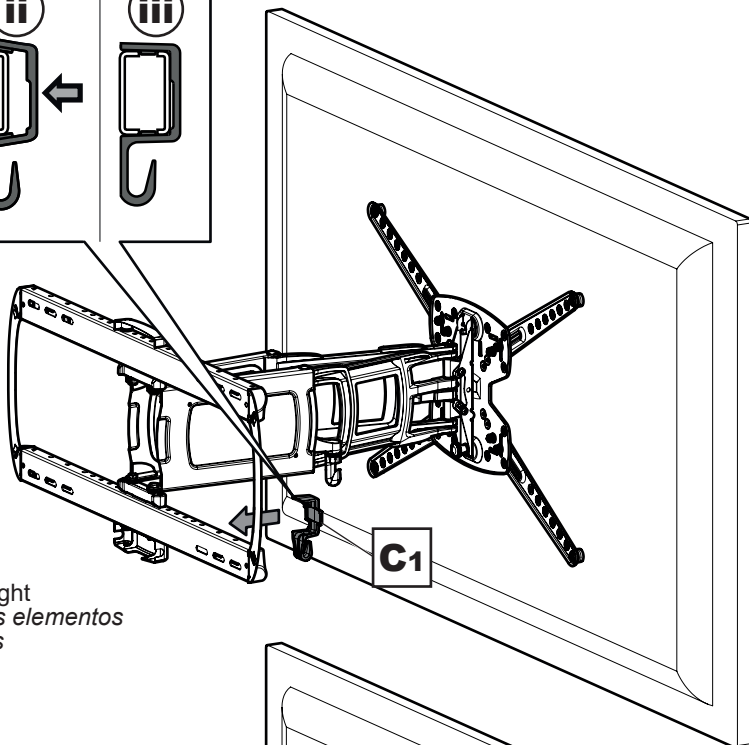
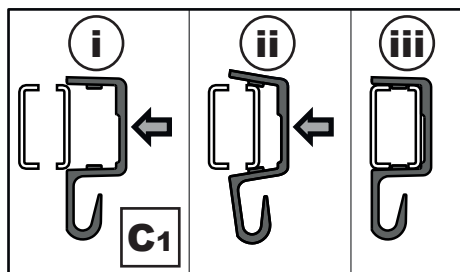

Check all fittings are tight  
*Verifique que todos los elementos  
queden bien ajustados*

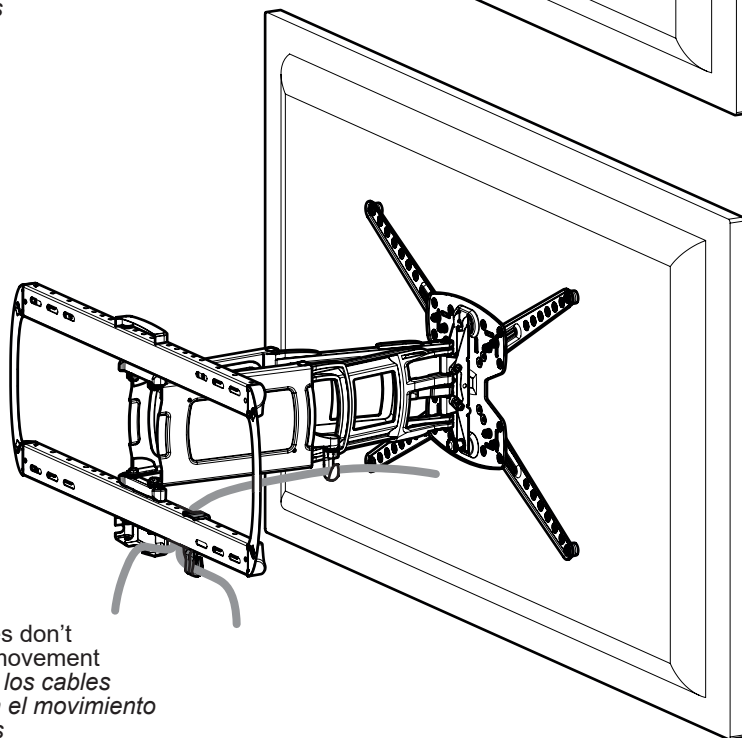

Ensure cables don't  
restrict arm movement  
*Asegure que los cables  
no restringen el movimiento  
de los brazos*

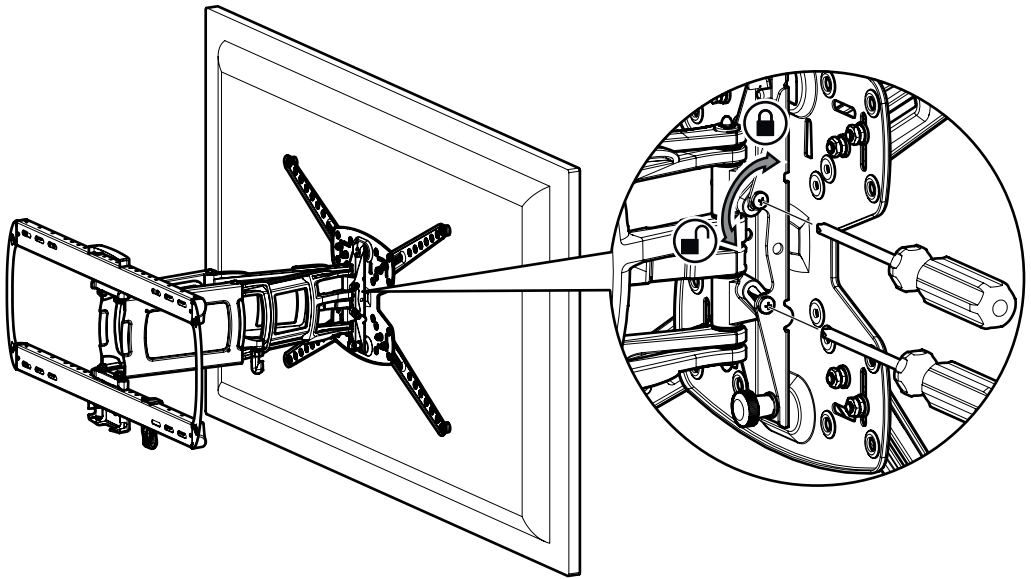
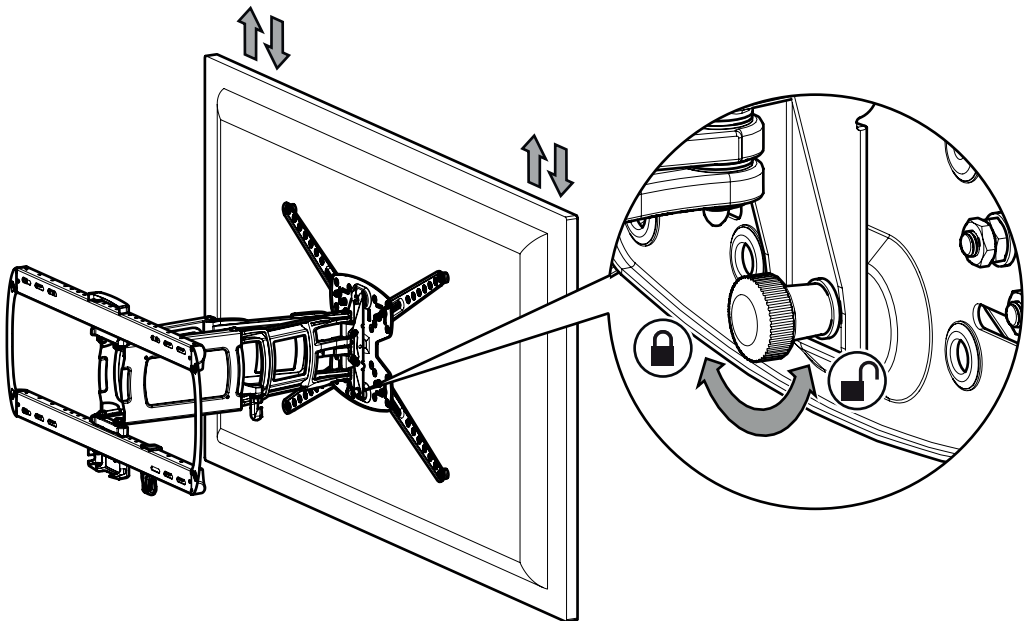
**10****Lock Tilt (optional)**  
*Ajuste de inclinación (opcional)***11****TV Levelling**  
*Nivelación de TV*

Loosen the Level Lock Screw, adjust your TV until it is level, then re-tighten the screw.  
*Afloje el tornillo de fijación de nivel, nivele su TV y vuelva a ajustar el tornillo.*