

469231 rev03

WICHTIGE INFORMATIONEN!

Bevor Sie mit der Montage dieses Produkts beginnen, sollten Sie sich mit den Anweisungen und der Teileliste in diesem Beipackzettel vertraut machen.

INFORMACIÓN IMPORTANTE!

Le raccomandamos que antes de comenzar el ensamblaje de este producto se familiarize con las instrucciones y la lista de partes en esta hoja informativa.

INFORMATIONS IMPORTANTES!

Nous vous recommandons de vous familiariser avec ces instructions et la liste des pièces détachées contenues dans ce document avant de commencer l'assemblage de ce produit.

Was Sie nicht tun sollten

Ziehen Sie keine Teile dieser Baugruppe zu fest an.

Stellen Sie keine heißen oder kalten Gegenstände auf oder in die Nähe von Glasflächen, es sei denn, der Gegenstand ist ausreichend isoliert, um einen Kontakt zu verhindern.

Schlagen Sie nicht mit harten oder spitzen Gegenständen gegen das Glas.

Setzen und stellen Sie sich nicht auf horizontale Glasflächen.

Verwenden Sie zum Reinigen des Glases keine Waschmittel oder andere Substanzen, die Scheuermittel enthalten.

Verwenden Sie das Produkt nicht, wenn das Glas abgebrochen oder beschädigt ist.

Da evitare

Evitare di stringere eccessivamente qualsiasi componente di questo assemblaggio.

Non collocare oggetti caldi o freddi sopra o nelle immediate vicinanze di qualsiasi superficie in vetro, a meno che l'oggetto non sia sufficientemente isolato da evitare il contatto.

Non colpire il vetro con oggetti rigidi o appuntiti.

Non sedersi o stare in piedi sulle superfici di vetro orizzontali.

Non utilizzare polveri detersivi o altre sostanze contenenti componenti abrasive in fase di pulizia del vetro.

Non utilizzare il prodotto se il vetro appare scheggiato o danneggiato.

Não

Não aperte demasiado qualquer peça desta montagem.

Não coloque objetos quentes ou frios em cima ou perto de qualquer superfície de vidro exceto se o objeto tiver um isolamento suficiente para impedir o contacto.

Não bata no vidro com itens rígidos ou pontiagudos.

Não se sente nem pise superfícies de vidro horizontais.

Não utilize detergentes em pó ou outras substâncias que contenham abrasivos ao limpar o vidro.

Não utilize este produto se o vidro estiver lascado ou danificado.

Was Sie tun sollten

Verwenden Sie zum Reinigen der Glasoberflächen ein feuchtes Tuch mit verdünntem Spülmittel.

Überprüfen Sie von Zeit zu Zeit alle Schrauben und Muttern.

Cosa fare

Per pulire le superfici in vetro, utilizzare un panno inumidito con liquido detergente diluito.

Controllare di tanto in tanto tutti i dadi e bulloni.

Faz

Utilize um pano húmido com detergente líquido diluído para limpar as superfícies de vidro.

Verifique todas as porcas e parafusos periodicamente.

Höchstgewicht des Fernsehers und Regalkapazitäten

Peso massimo del televisore e capacità dei ripiani

Peso máximo da TV e capacidades de prateleira

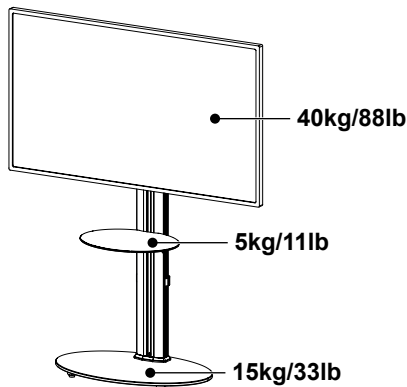

WARNHINWEIS: Wenn möglich, das Gewicht gleichmäßig verteilen.

ATTENZIONE: ove possibile, distribuire il peso uniformemente.

AVISO: Sempre que possível, distribua o peso uniformemente.

Empfohlene Tools
Attrezzi consigliati
Ferramentas Recomendadas

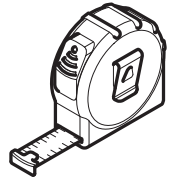
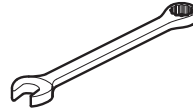
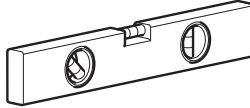

Verpackte Teile
Parti contenute nella confezione
Peças Embaladas



D

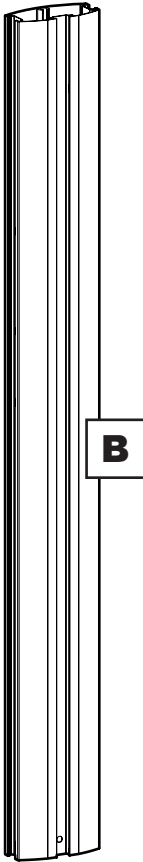

B

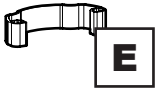

E



E

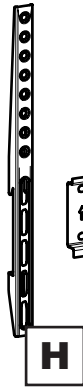

H

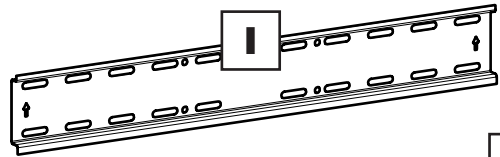

I

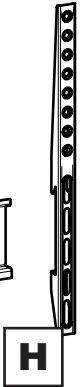

H

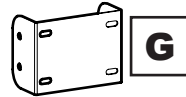

G



F1

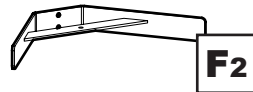

F2



C1



C2



A

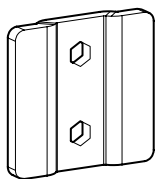

J1 x1



J3 x4



J4 x12



J5 x1

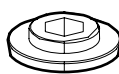

J6 x4



J7 x4



M6

J8 x6

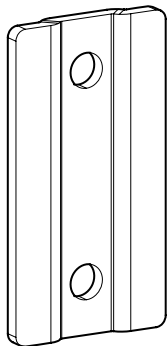

J2 x2

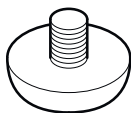

J9 x4

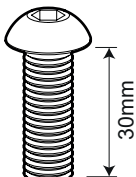

M10

J10 x1

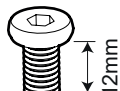

M8

J11 x4

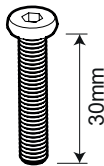

M6

J12 x2

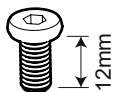

M6

J13 x7

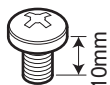

M6

J14 x2

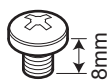

M6

J15 x1



K1 x1

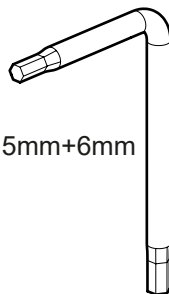

K2 x1

TV-Schrauben, Übergangsstücke und Abstandshalter
Viti, riduttori e distanziatori per la TV
Parafusos de TV, Redutores e Espaçadores



RE1 x4



RE2 x4



SP1 x4



M4

TV1 x4

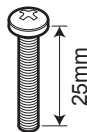

M4

TV2 x4

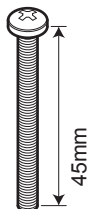

M4

TV3 x4

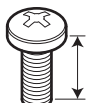

M6

TV4 x4

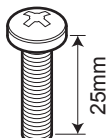

M6

TV5 x4

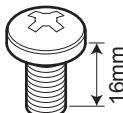

M8

TV6 x4

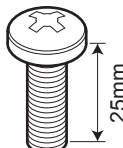

M8

TV7 x4

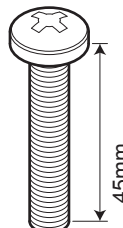

M8

TV8 x4

1

Messen Sie die Breite und Höhe der TV-Befestigungslöcher
 Misurare la larghezza e l'altezza dei fori di fissaggio della TV
 Meça a Largura e Altura dos orifícios de fixação da TV

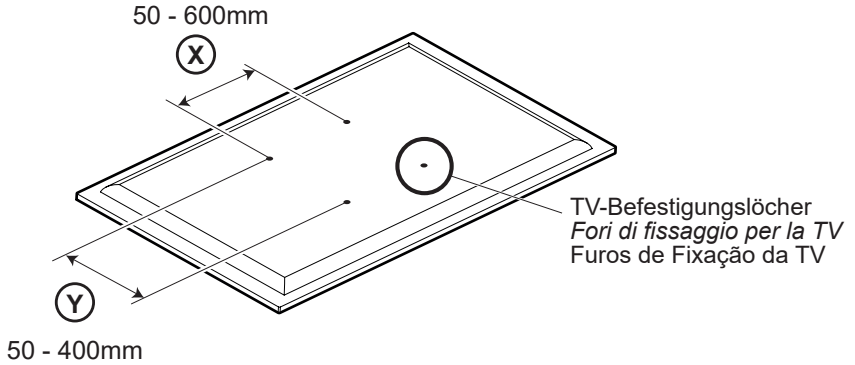

Wenn die Breite (X) größer als 600mm oder die Höhe (Y) größer als 400mm ist, STOPPEN Sie die Installation jetzt und kontaktieren Sie die Hotline des Kundendienstes.

Se la larghezza (X) è superiore a 600mm oppure l'altezza (Y) è superiore a 400mm, fermare subito l'installazione e contattare l'assistenza clienti.

Se a largura (X) for maior do que 600mm ou a altura (Y) maior do que 400mm INTERROMPA já a instalação e entre em contacto com a linha de assistência ao cliente

Sie erhalten 3 Durchmesser der TV-Befestigungsschrauben **M4, M6 und M8**.
 Bestimmen Sie den passenden Schraubendurchmesser und merken Sie sich ihn für Schritt 2.
 Vengono forniti viti di fissaggio della TV di 3 diametri: **M4, M6 e M8**.
 Determinare il diametro della vite che si adatta meglio e ricordarselo per il passaggio 2.
 São fornecidos 3 diâmetros de parafusos de fixação de TV, **M4, M6 e M8**.
 Determine o diâmetro do parafuso que couber e lembre-se do passo 2.

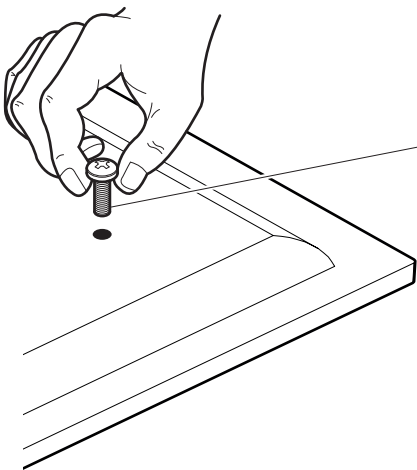

M4 = TV₁-TV₃

M6 = TV₄-TV₅

M8 = TV₆-TV₈

2

Anbringen der TV-Halterungen
Regolazione dei supporti della TV
 Ajustar os Suportes da TV

Keine Abstandshalter
Nessun distanziatore
 Sem Espaçadores

Für Fernseher mit flachem/frei zugänglichem Rücken
Per TV dalla parte posteriore piatta o sgombra
 Para TV com a parte traseira plana/desobstruída

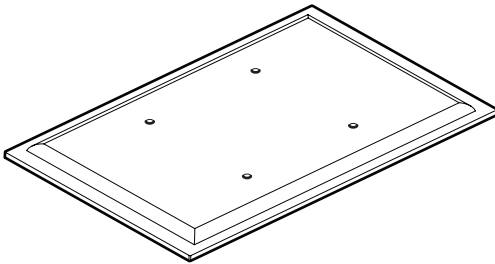

Abstandshalter
Distanziatori
 Espaçadores

SP1

Für Fernsehgeräte mit unregelmäßigem/blockiertem Rücken
Per TV dalla parte posteriore irregolare o ostruito
 Para TV com a parte traseira irregular/obstruída

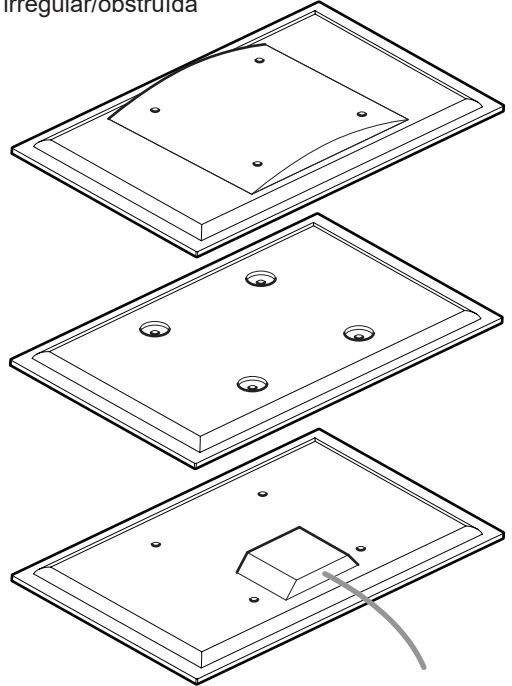

WARNHINWEIS / ATTENZIONE / AVISO

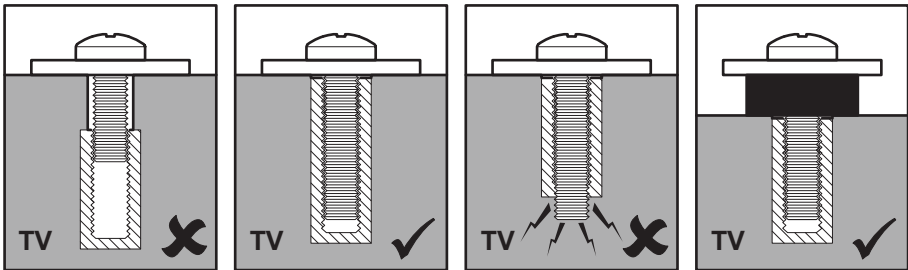

Nachdem Sie Schritt 2 abgeschlossen haben, werden Sie noch Halterungen übrig haben. Bitte bewahren Sie diese für eine spätere Verwendung auf.

Dopo aver completato il passaggio 2, avanzeranno delle giunzioni. Si prega di conservarle in caso di futura necessità.

Depois de completar o passo 2, irão sobrar-lhe acessórios, por favor, guarde para referência futura.



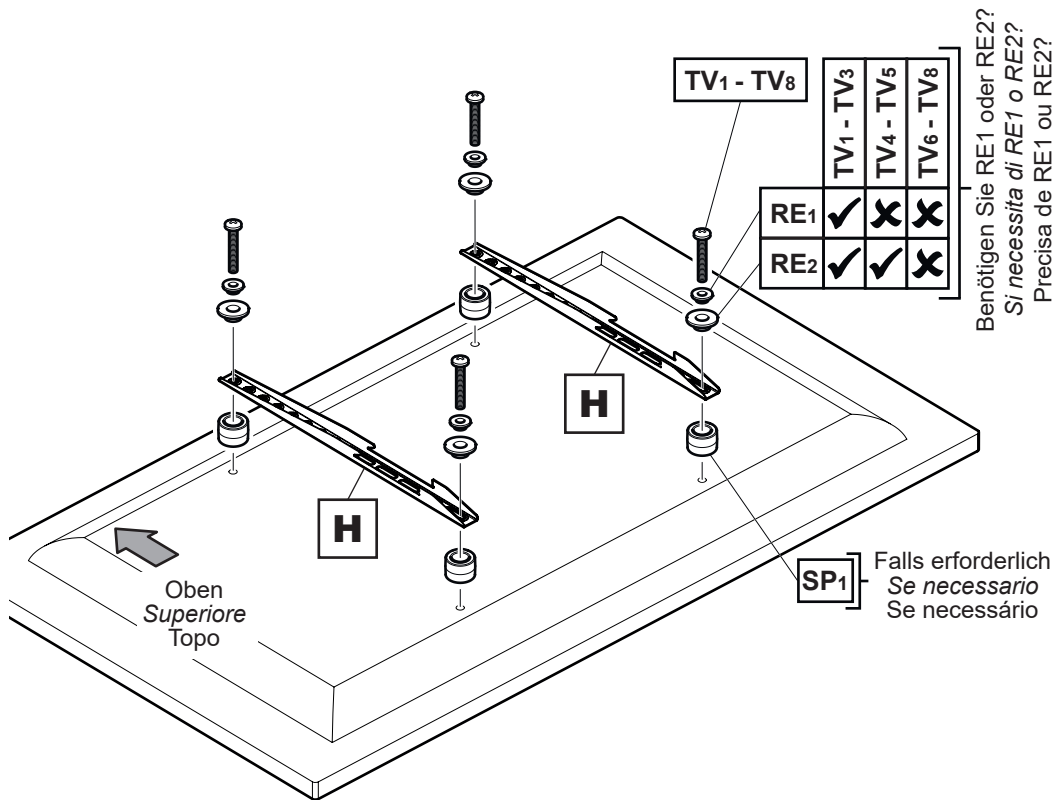

Befestigen Sie die Halterung mit geeigneten Kombinationen aus Schrauben, Übergangsstücken und Distanzstücken an der Rückseite Ihres Fernsehgeräts.

Fissare la staffa al retro della TV, utilizzando combinazioni adatte di viti, riduttori e distanziatori.

Prenda o suporte à parte traseira da sua TV utilizando as combinações adequadas de parafuso, redutor e espaçador.

3



Kork-Verpackung entfernen
Rimuovere l'imballaggio di sughero
Retirar a embalagem de cortiça

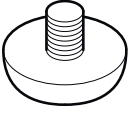
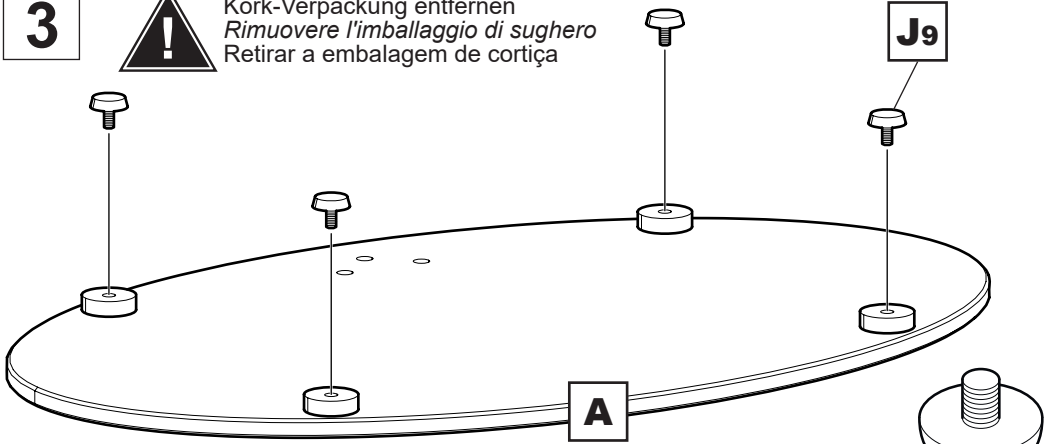

J9 x4

4

J8

J4

J6

C1

C2

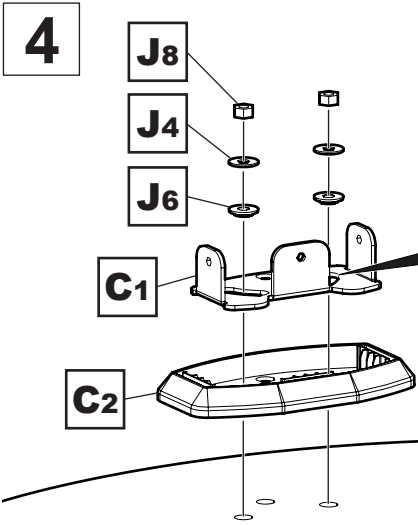
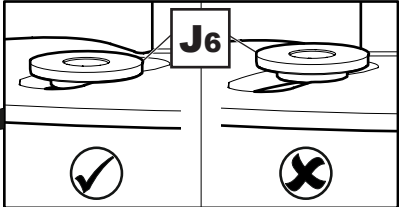

M6

J8 x2



J4 x4

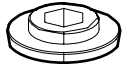

J6 x4

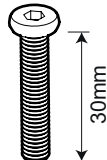

M6

J12 x2



NICHT zu fest anziehen
NON stringere troppo
NÃO aperte em excesso

J6

J4

J12

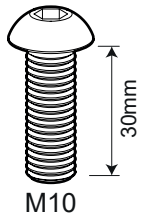
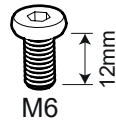
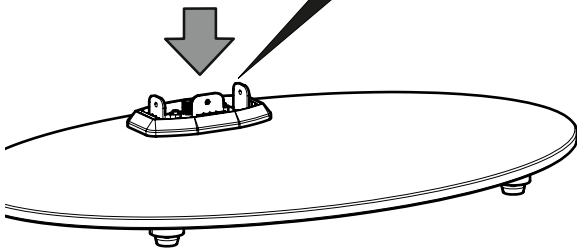
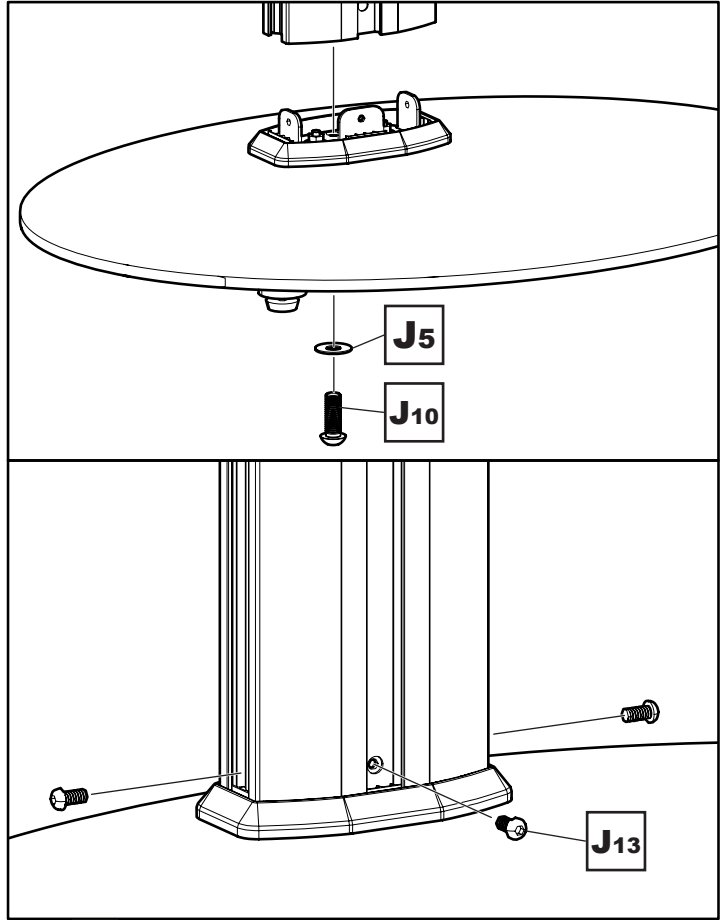
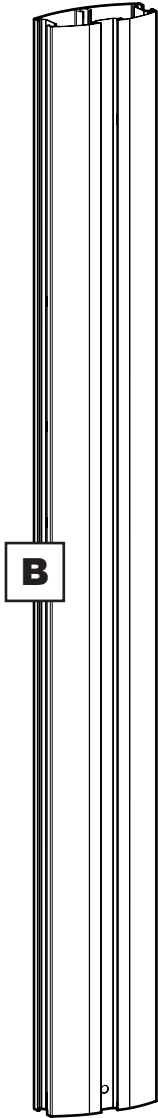

J13 x3

J5 x1

J10 x1

5

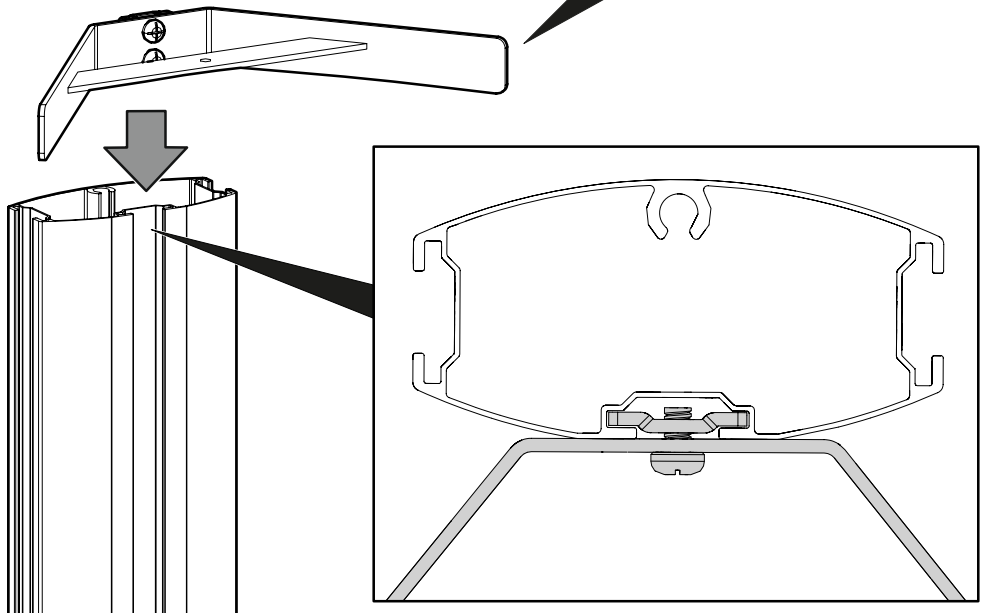
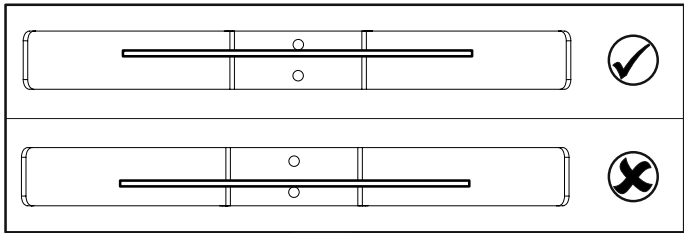
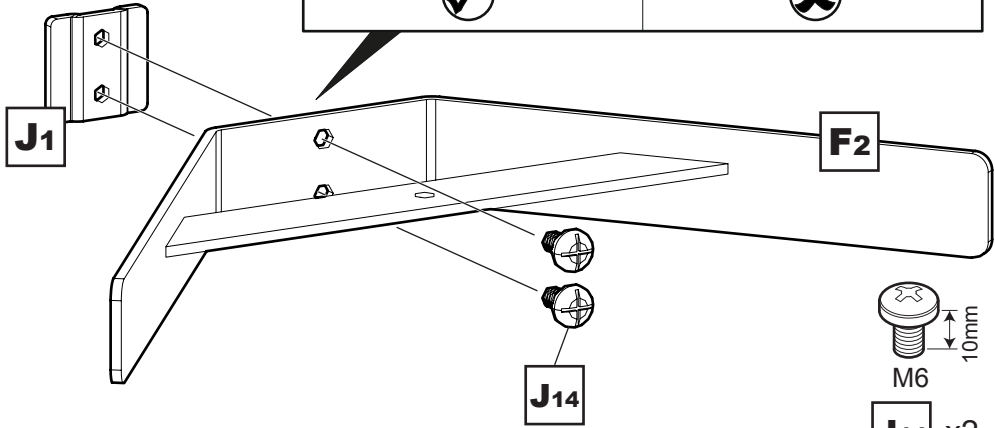
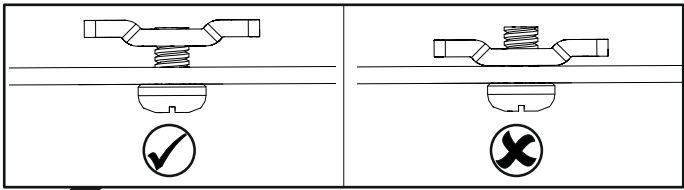

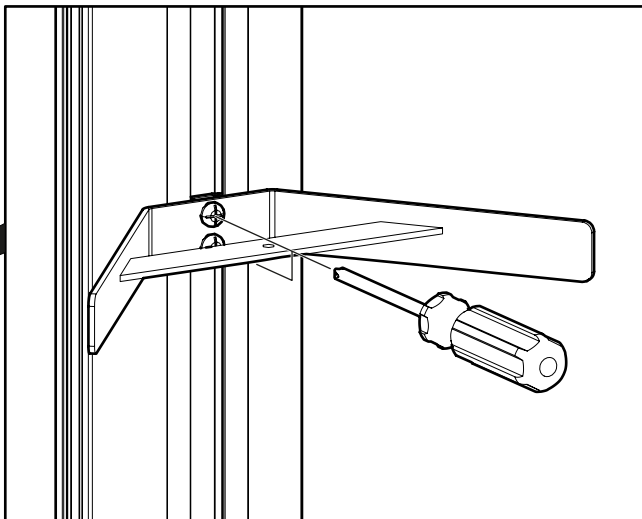
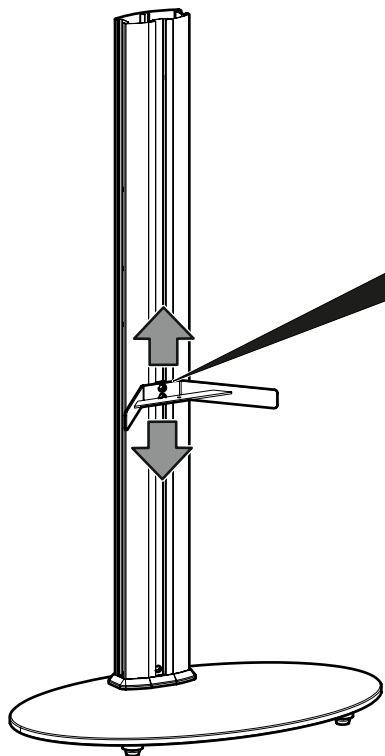

Wählen Sie die Höhe, bevor Sie die Schrauben festziehen, um sie in Position zu halten.

Scegliere l'altezza prima di stringere le viti per mantenerlo in posizione.

Selecione a altura antes de apertar os parafusos para manter a posição.

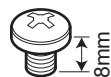
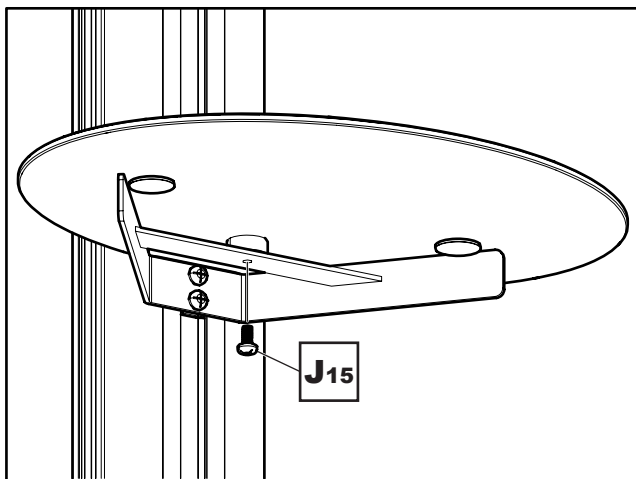
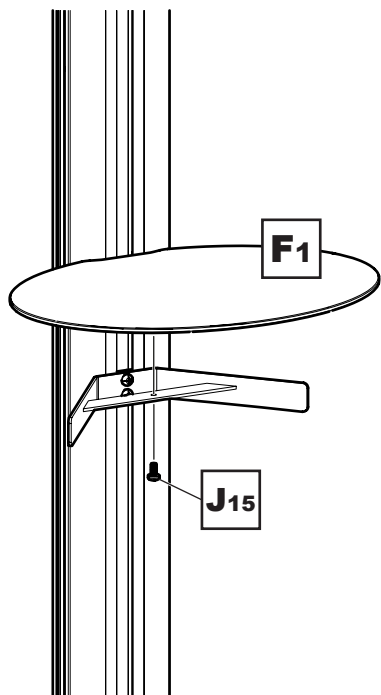

M6

J15 x1

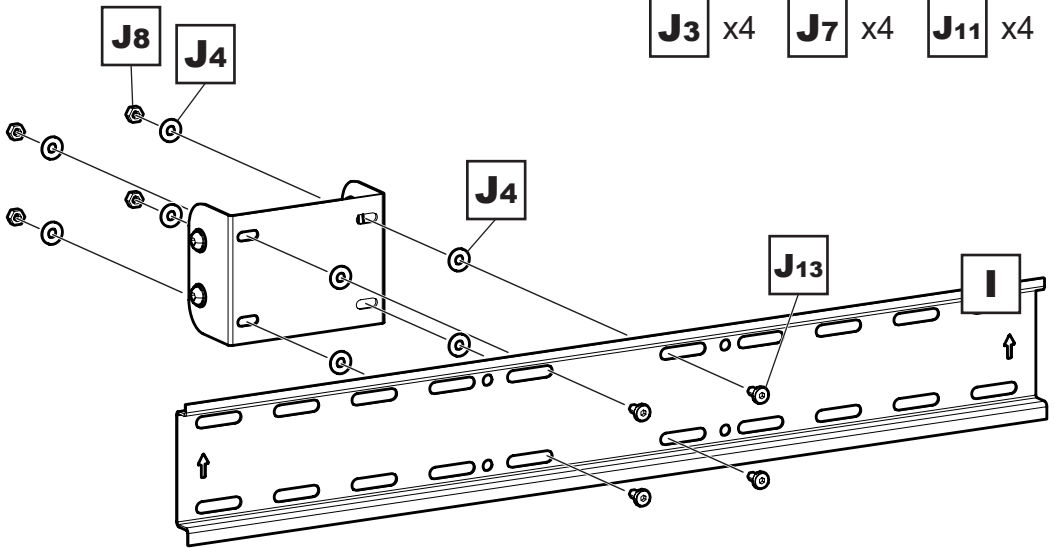
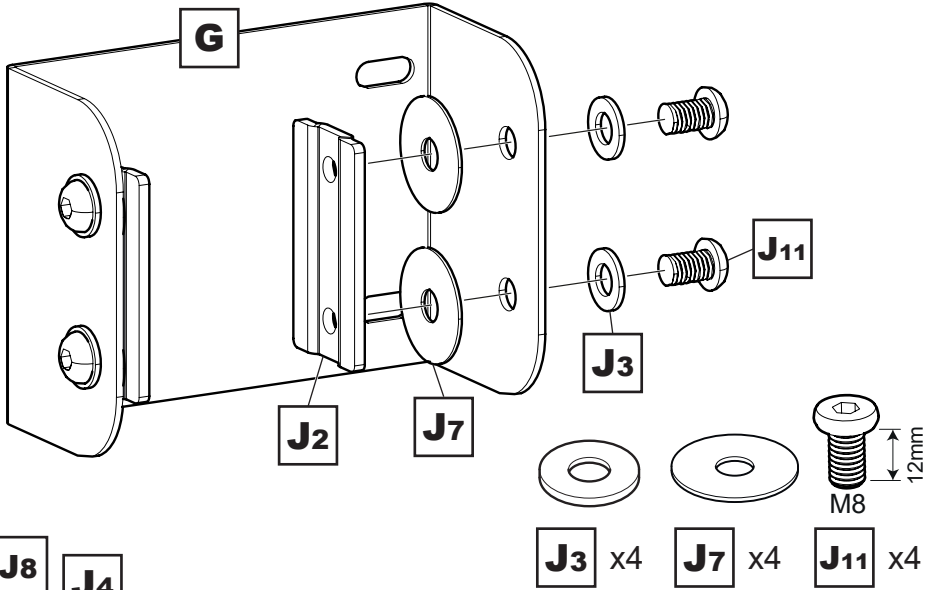
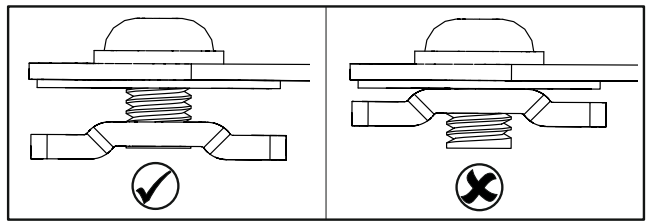
6

Sicherstellen, dass die Rückwand I waagrecht sitzt, bevor die Schrauben festgezogen werden.
Assicurarsi che la piastra posteriore I sia in piano prima di serrare.
 Assegure-se de que a Placa Traseira I esteja nivelada antes de apertar.

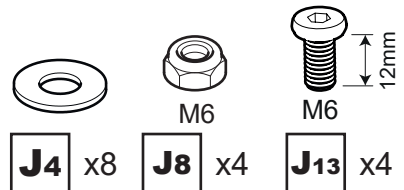

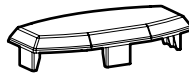
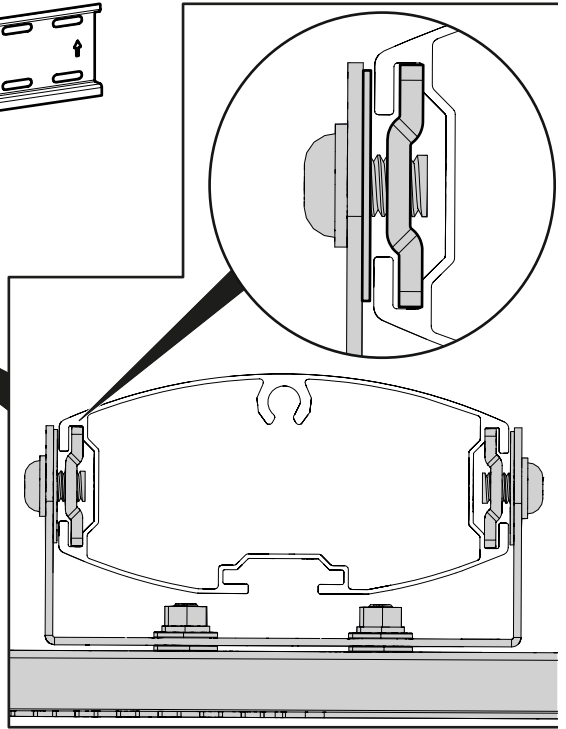
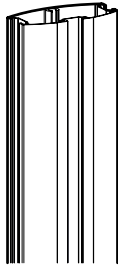
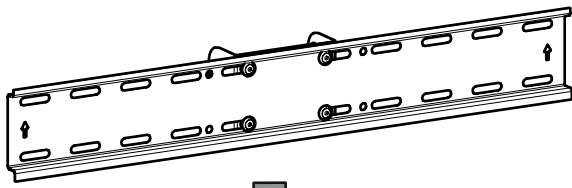

D

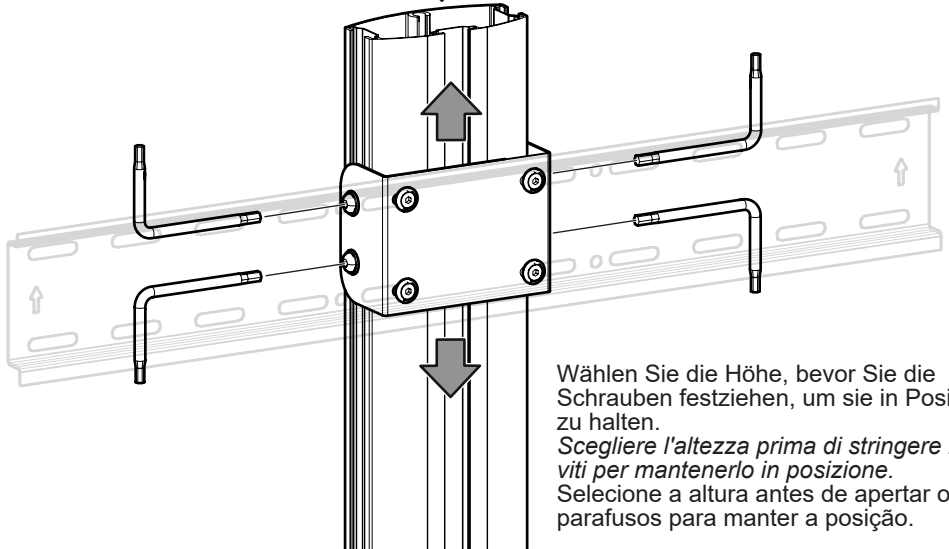

Wählen Sie die Höhe, bevor Sie die Schrauben festziehen, um sie in Position zu halten.

Scegliere l'altezza prima di stringere le viti per mantenerlo in posizione.

Selecione a altura antes de apertar os parafusos para manter a posição.

7

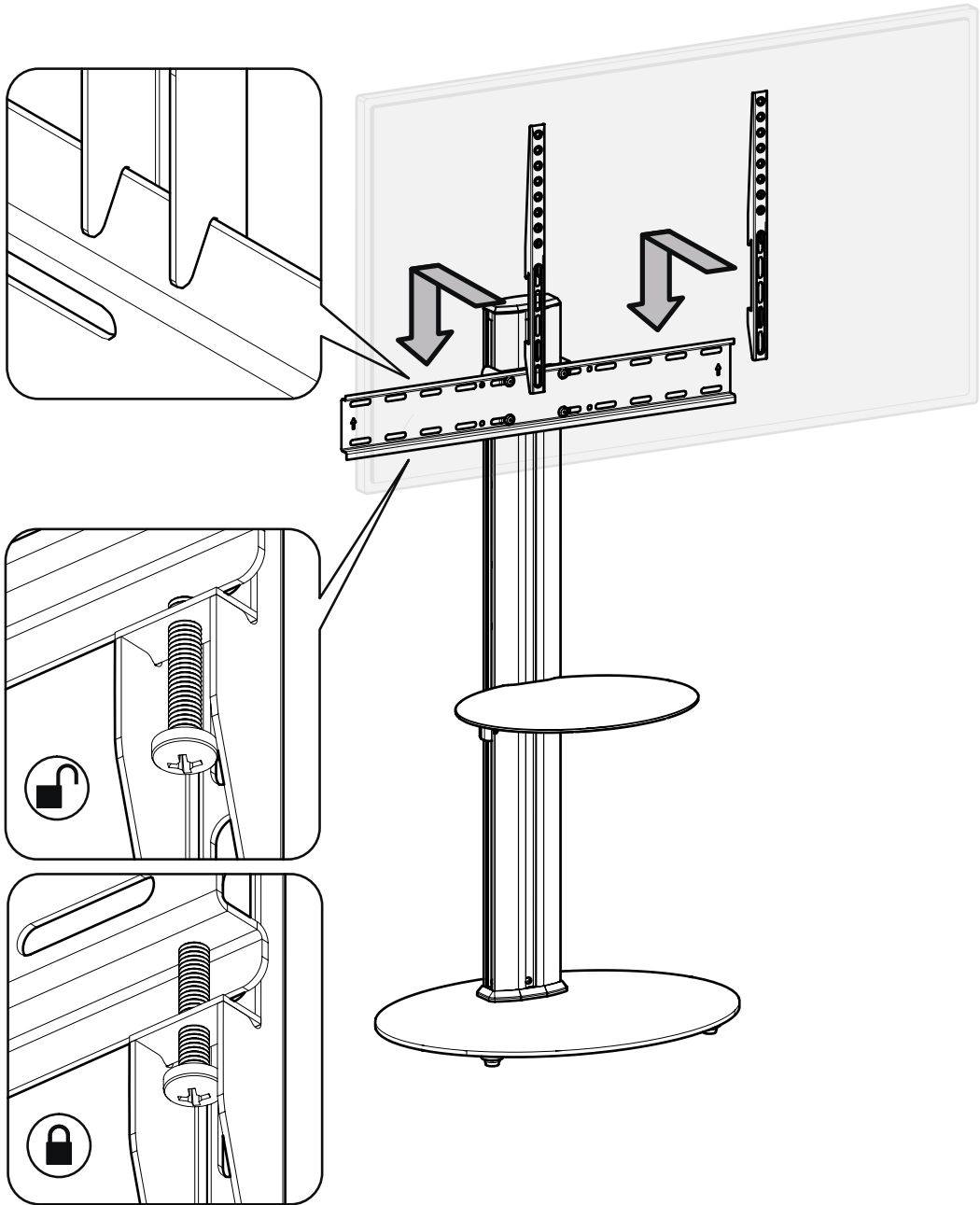

8

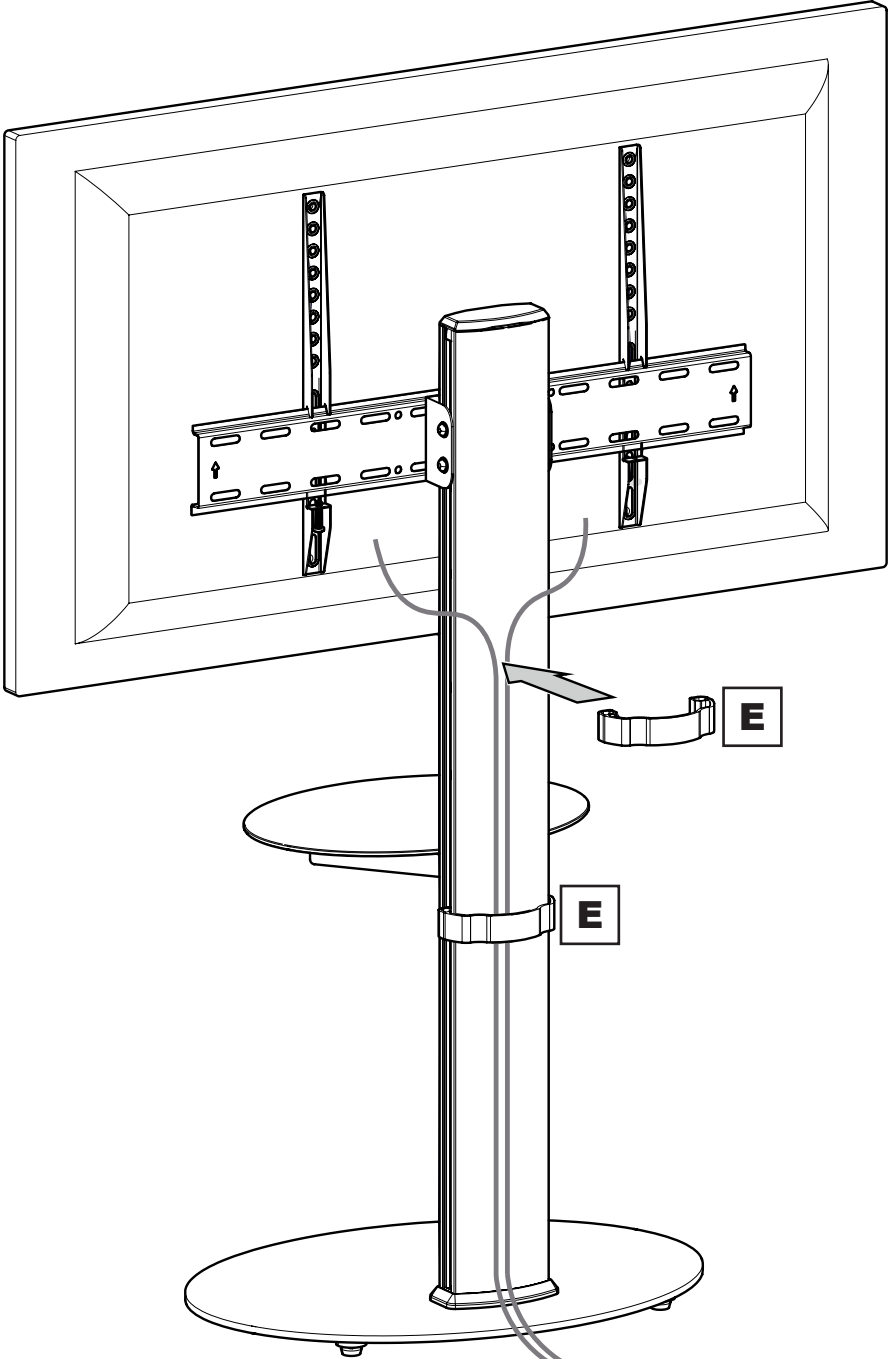

9

Optional
Opzionale
Opcional

