

60kg  
132lbs



Read through **ALL** instructions before commencing installation.

If you have any questions about this product or issues with installation, contact the customer services helpline before returning this product to the store.



This TV Wall Mount is intended for use with televisions weighing **Maximum 60kg (150lbs)**. Use with products heavier than maximum weights may result in instability causing possible injury.

CUSTOMER SERVICES HELPLINE NUMBER: **0333 320 0463 (UK)**

## Assembly Overview

Fit the TV Brackets

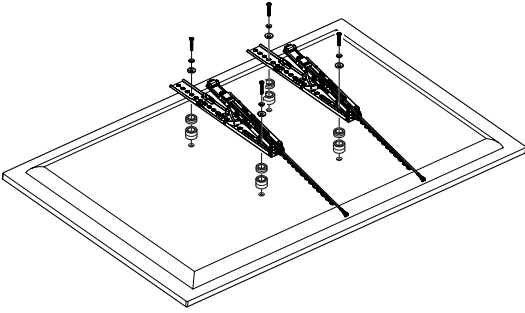

Determine your TV position

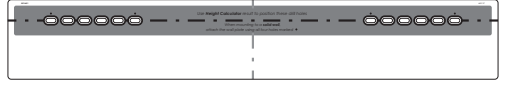

Fit the Wall Rail

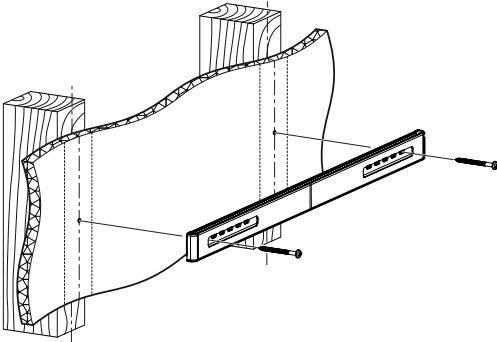

Hang the TV

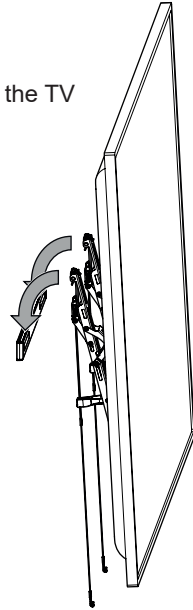

## Suitable Wall Types

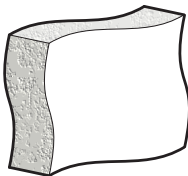

Solid Wall

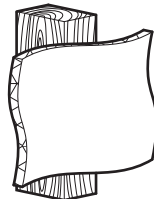

Wood Stud

## Index

**1** Measure the TV fixing holes Width and Height

**2** Preparing the TV Brackets

**3** Fitting the TV Brackets

**4** Preparing the Wall Rail

**5** Marking Wall for Drill Points

**6** Fitting the Wall Rail

**7** Fitting the Wall Rail Covers

**8** Hanging the TV

**9** Hide the TV Release Cords

**10** Return the TV to the Wall

**11** Hide the TV Return Straps

Retain all packaging in case the product needs to be returned.

Contents may vary from photography / illustrations.

You will not need all these parts, so expect there to be some left over depending upon the specification of your TV.

This product is intended for indoor use only. Use of this product outdoors could lead to failure and personal injury.

It is the responsibility of the installer to ensure that the mounting wall is of a suitable standard and void of any services (eg gas, electricity, water etc).

AVF accept no responsibility for any damage or loss caused by installing this product in a substandard wall.

## Tools Recommended

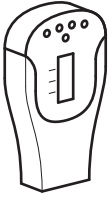

Stud Finder

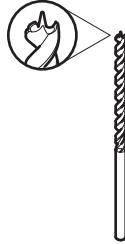
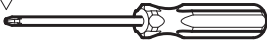
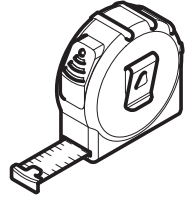
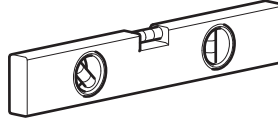
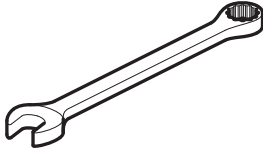

Ø3mm (1/8")  
Wood

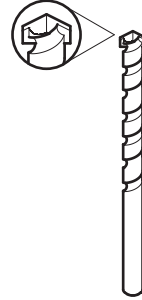

Ø10mm (25/64")  
Masonry

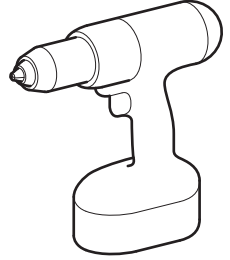

## TV Screws, Reducers and Spacers



**D1** x4



**D2** x4



**E1** x12



**E2** x4



M4

**F1** x4

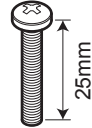

M4

**F2** x4

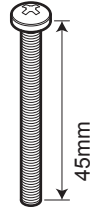

M4

**F3** x4



M5

**F4** x4

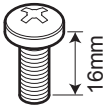

M6

**F5** x4

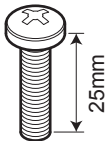

M6

**F6** x4

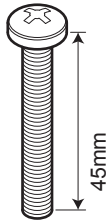

M6

**F7** x4

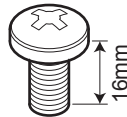

M8

**F8** x4

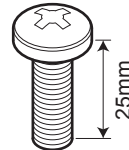

M8

**F9** x4

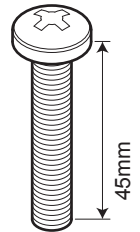

M8

**F10** x4

# Boxed Parts

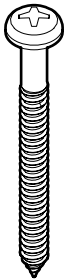
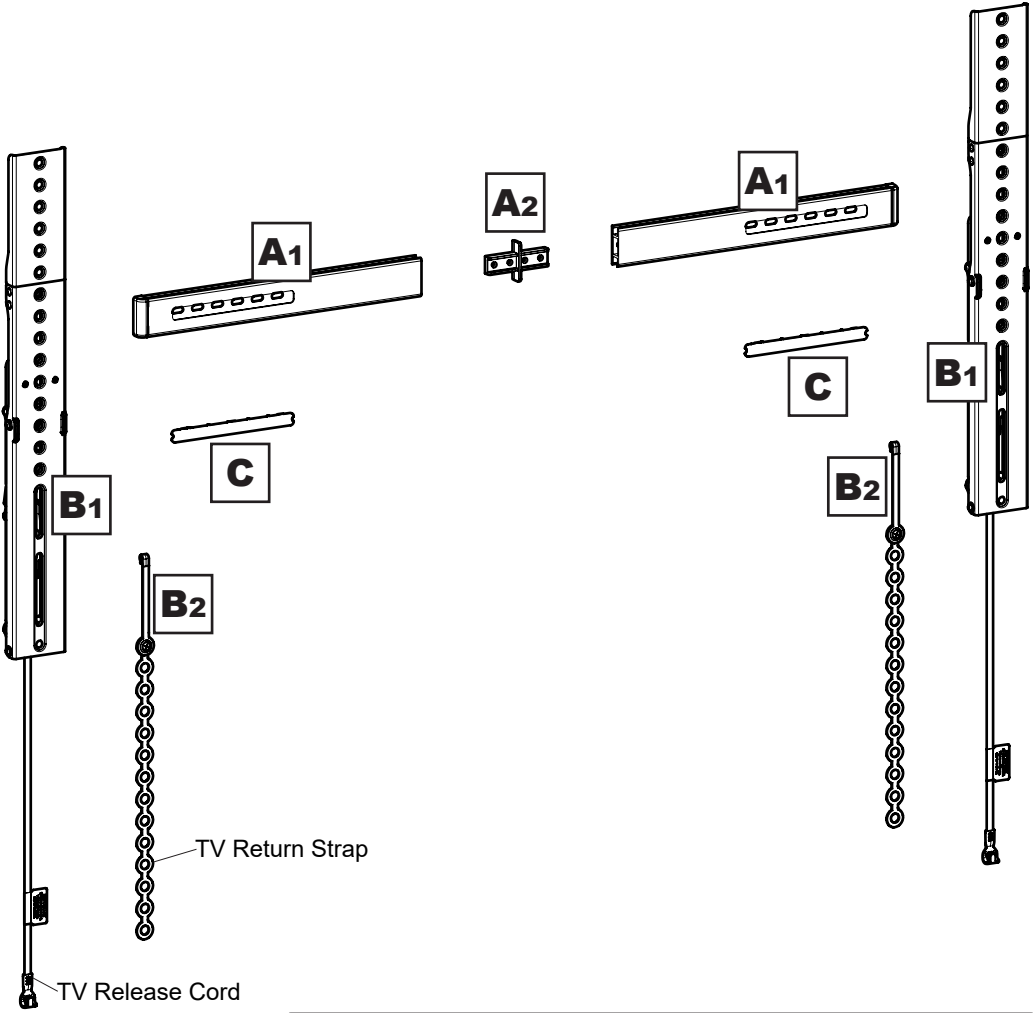

**G** x4

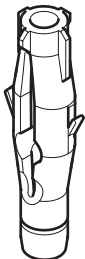

**H** x4

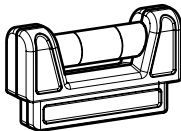

**I**



**J** x4

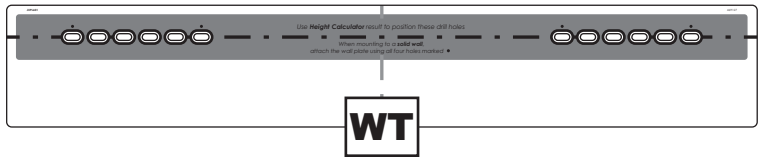

# 1 Measure the TV fixing holes Width and Height

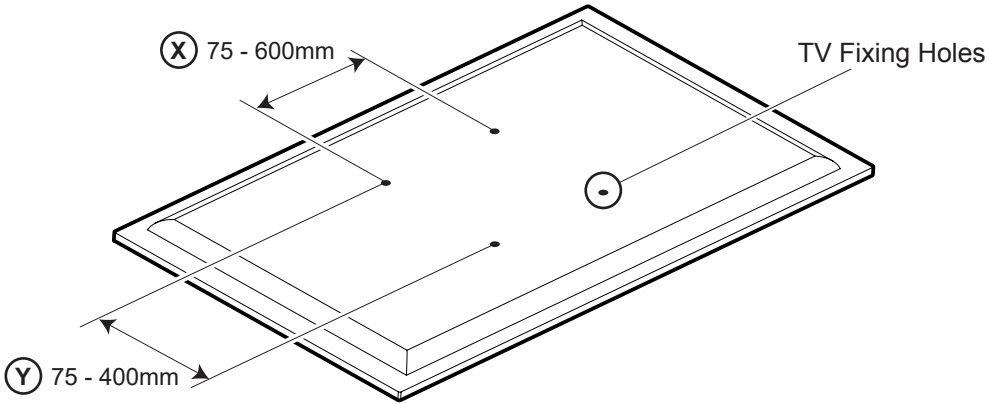

If width (X) is greater than 600mm or height (Y) greater than 400mm  
STOP installation now and contact the customer helpline

You are provided with 4 diameters of TV fixing screws, **M4**, **M5**, **M6** and **M8**.  
Determine the screw diameter that fits and remember for step 3.

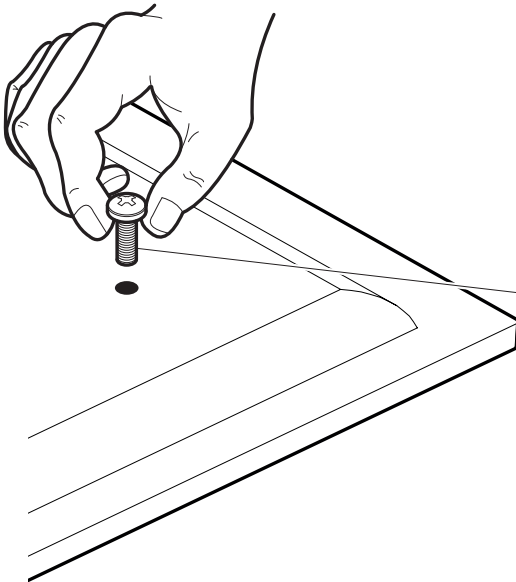

**M4 = F1-F3**

**M5 = F4**

**M6 = F5-F7**

**M8 = F8-F10**

After completing step 3 you will have fixings left over, please keep for future reference.

# 2

## Preparing the TV Brackets

To ensure maximum tilt is possible after installation you will need to ensure that your TV does not clash with the wall.

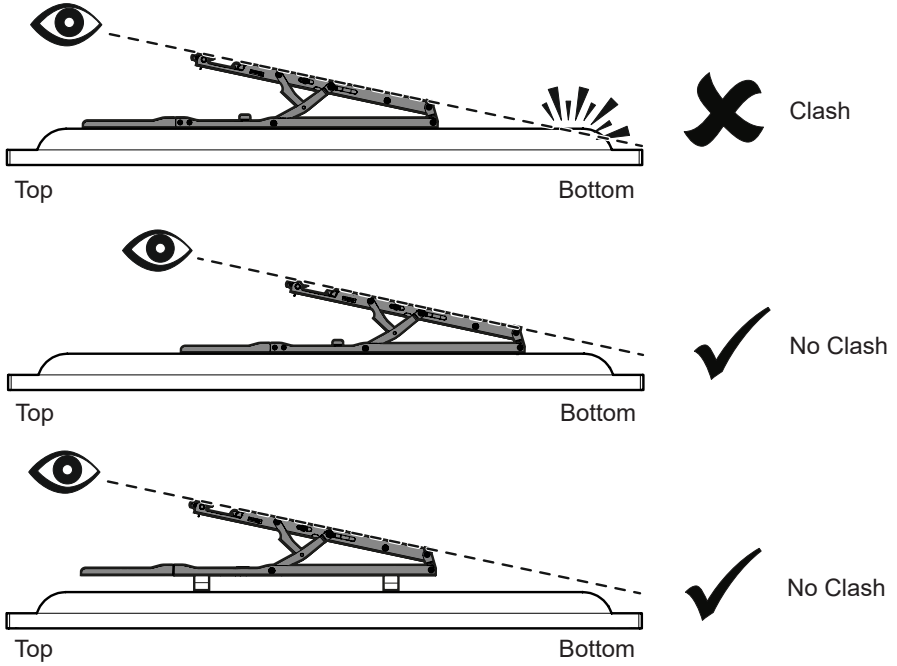

If the top of the TV Brackets extend above the top of the TV you can remove the top portion of the TV Brackets if required.

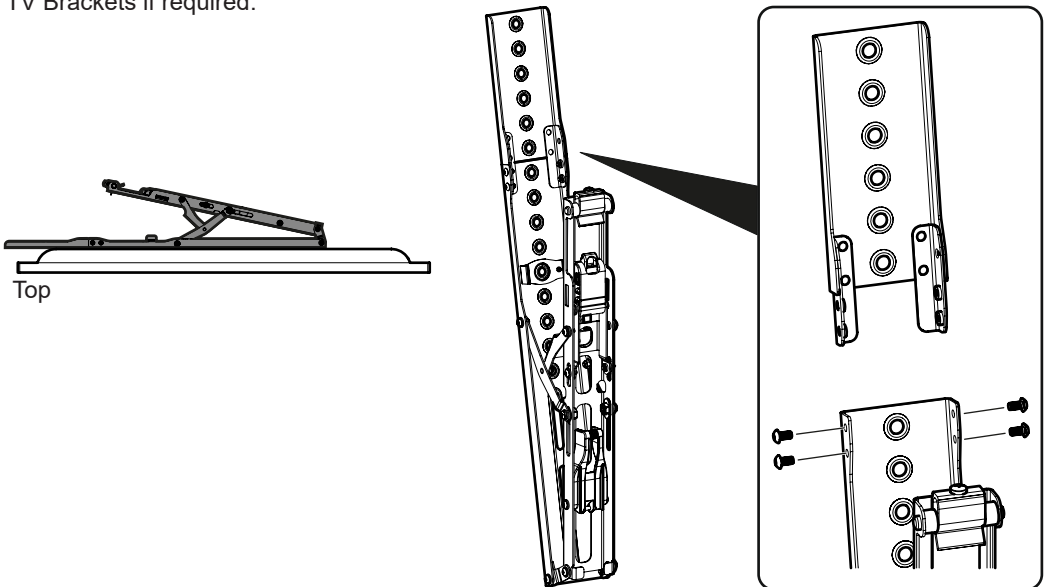

## Fitting the TV Return Straps

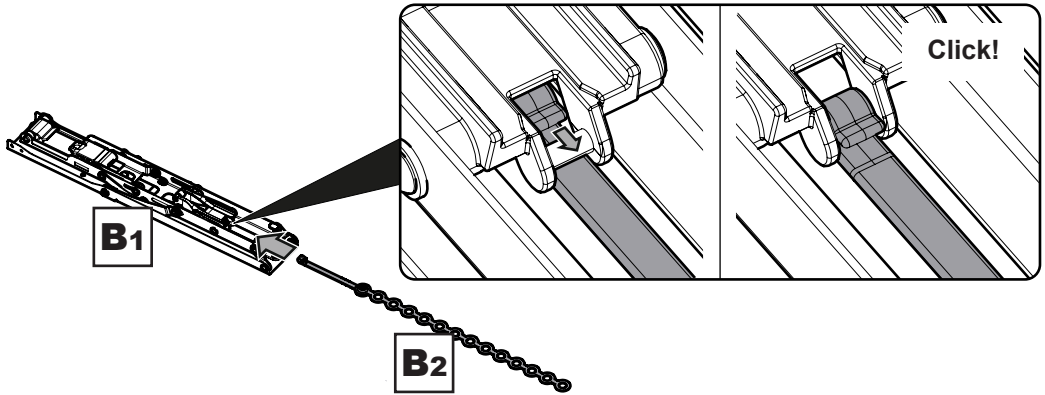

## 3 Fitting the TV Brackets

### No Spacers

For TVs with flat / unobstructed back.

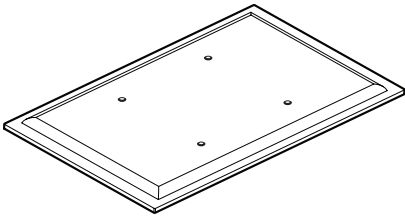

### Spacers

**E1/E2**

For TVs with irregular / obstructed back.

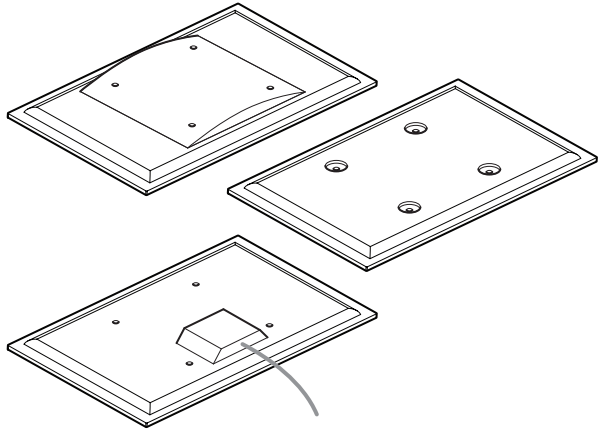

WARNING

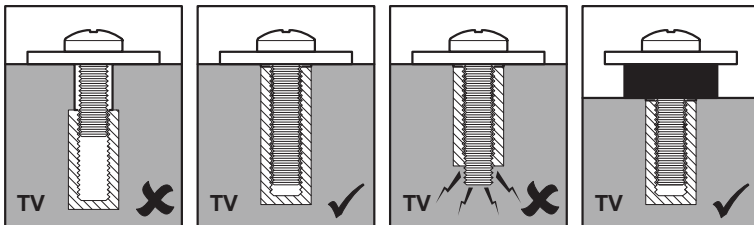

If your TV has an irregular/obstructed back or if you have any issues fitting to the back of your TV with the supplied screws, please call the customer services helpline.



For easy access to some of the TV fixing holes, follow the procedure on the next page.

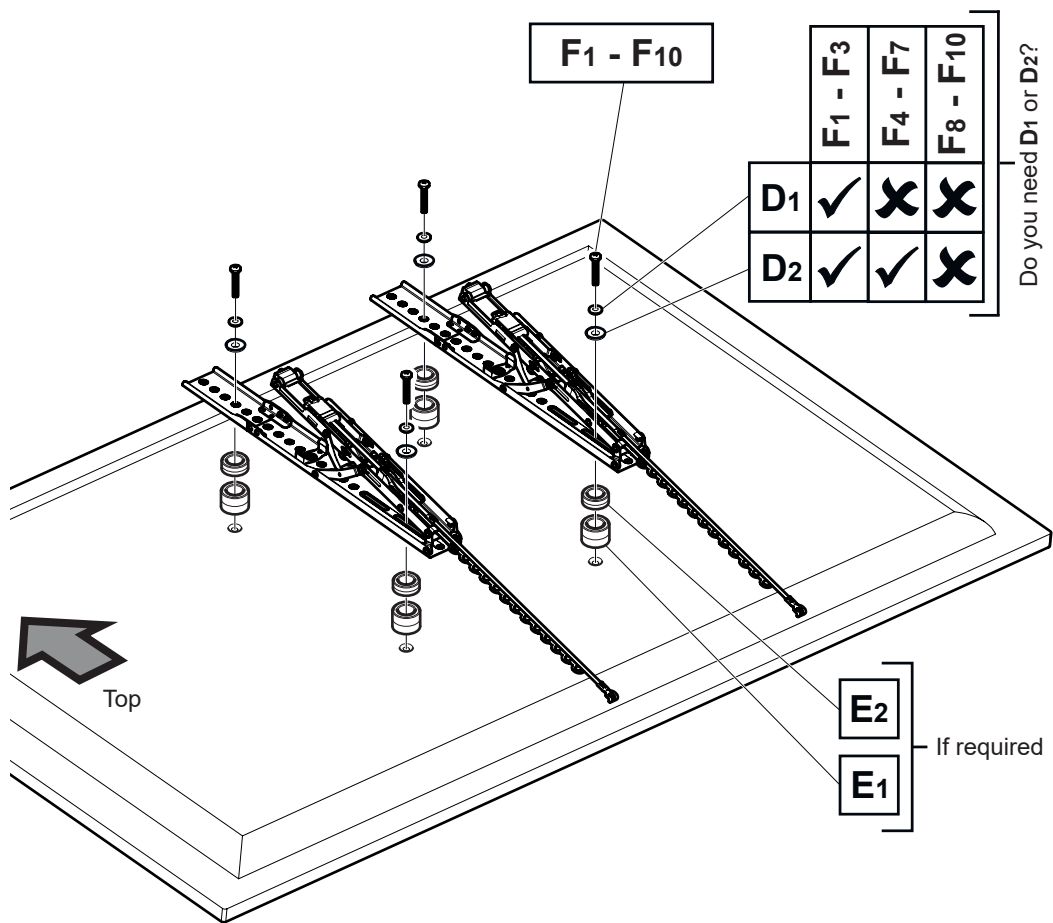

Attach the brackets to the back of your TV using suitable screw, reducer and spacer combinations.



After completing step 3 you will have fixings left over, please keep for future reference.

## Easy Access to TV Fixing Holes



This procedure is only necessary if you are having difficulty fitting screws into your TV.

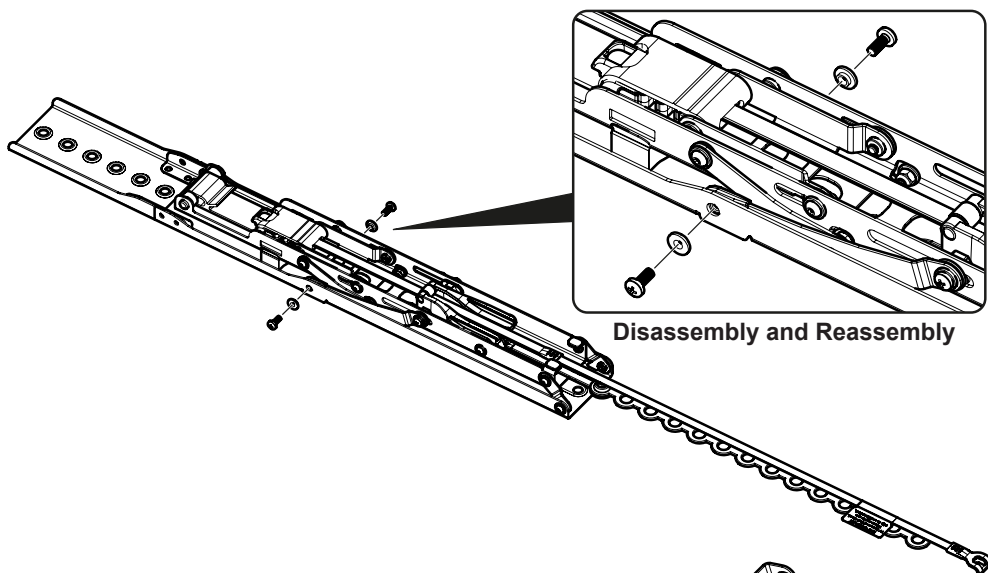

Disassembly and Reassembly

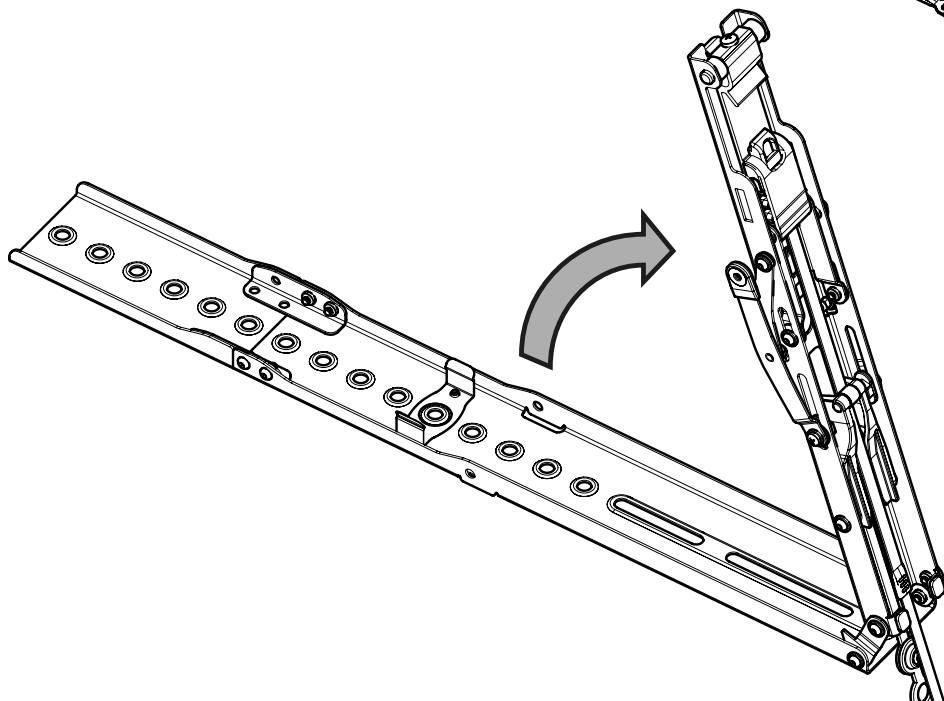

You must fully reassemble the TV Brackets when you have finished fixing them to the back of the TV.

## 4 Preparing the Wall Rail

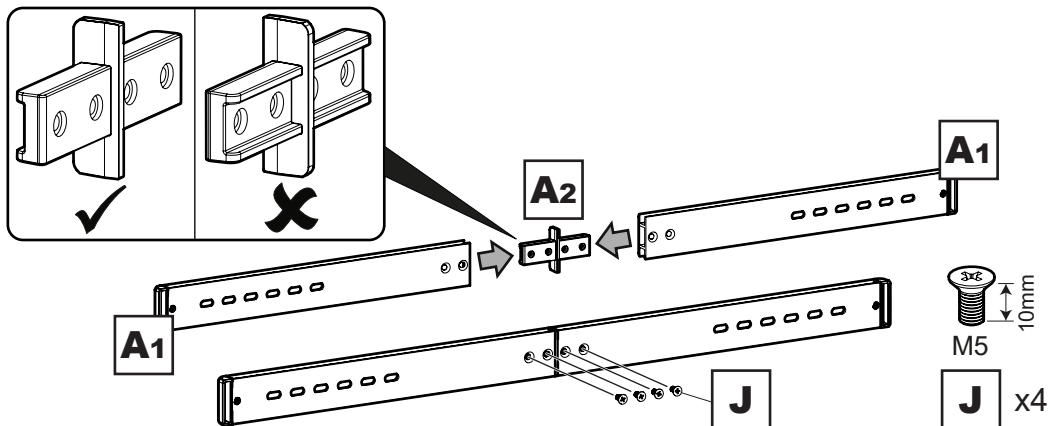

## 5 Marking Wall for Drill Points



For this step you will need your Wall Marking Template **WT**.

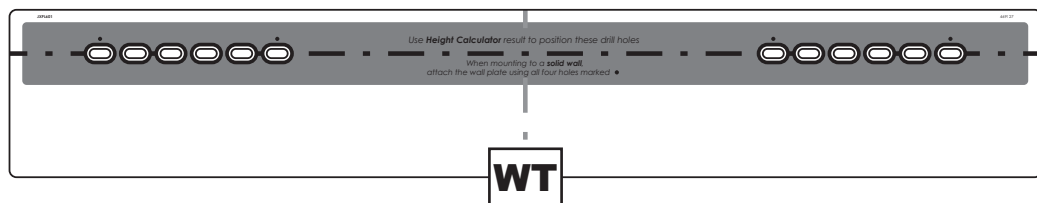

To determine the exact position for your drill points use the Height Calculator app. Follow the link to the app shown on your Wall Marking Template.

Before marking any drill points you will need to determine the wall type that you have, either **Solid Wall** or **Wood Stud Wall**. Ensure the drilling area is free from mains services (Gas / Electric / Water).

If fixing to a wood stud wall you must place the drilling template so that the drilling holes are over two wood studs.

Before you drill make sure you are happy with the position and ensure the holes are level.

# 6

## Fitting the Wall Rail

### Solid Wall

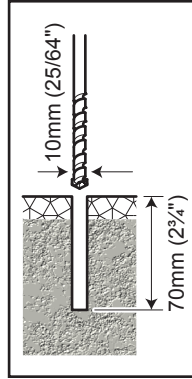
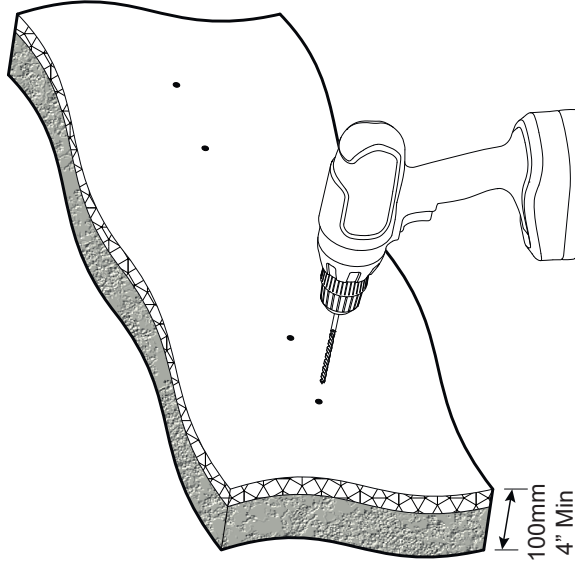

Remove Dust from Hole.



### Wood Stud

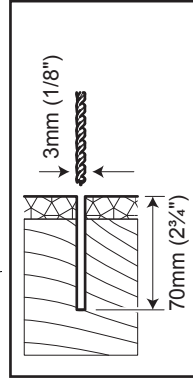
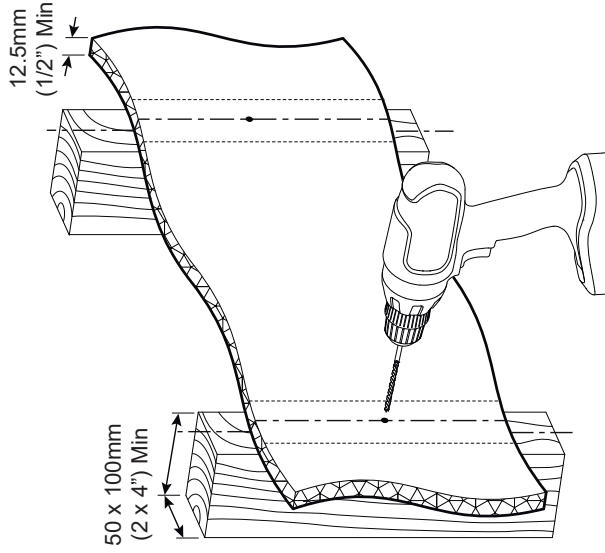

Ensure you drill in the centre of the wood stud



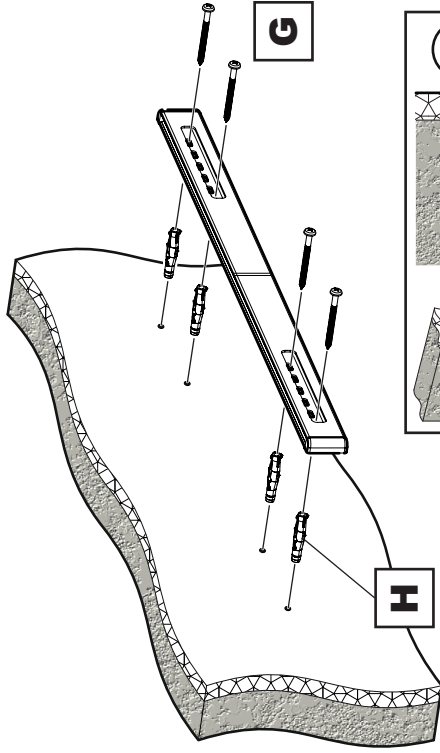

**G**

**H**

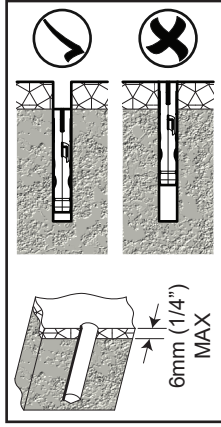

6mm (1/4")  
MAX

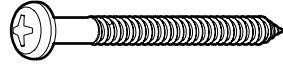

**G** x4

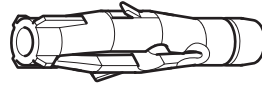

**H** x4



Lubricate screw thread with soap.



DO NOT overtighten screws.  
Tighten screws by hand only

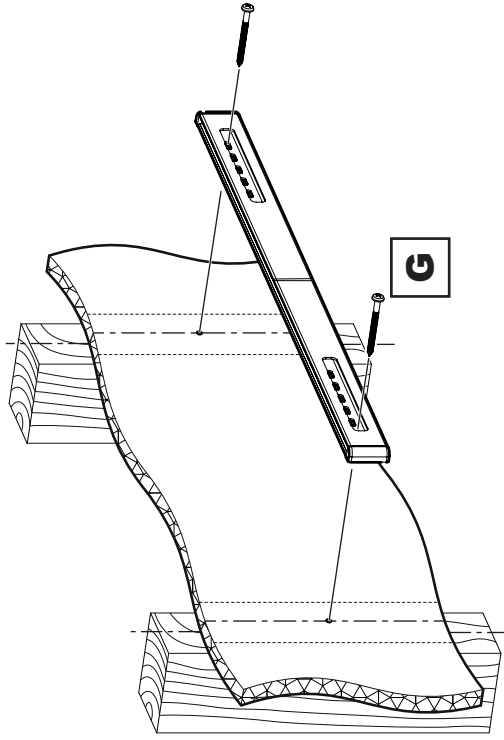

**G**



Lubricate screw thread with soap.



DO NOT overtighten screws.  
Tighten screws by hand only



DO NOT use wall plugs in a wood stud wall.

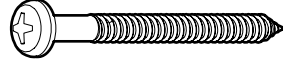

**G** x2

# 7

## Fitting the Wall Rail Covers

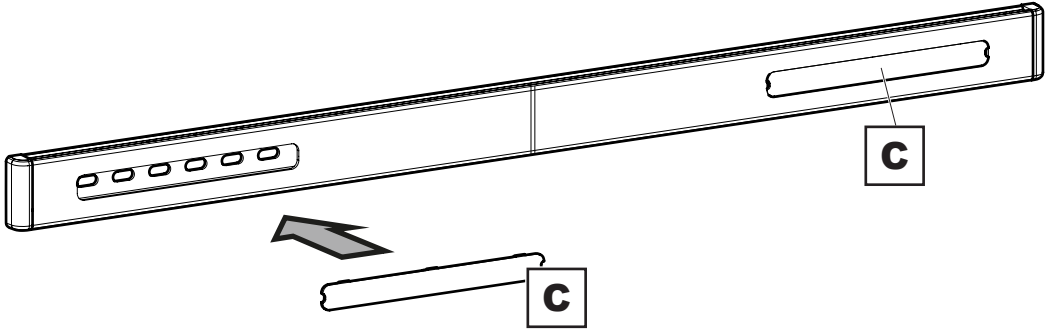

# 8

## Hanging the TV



Fully extend the TV Brackets before connecting the TV.



i

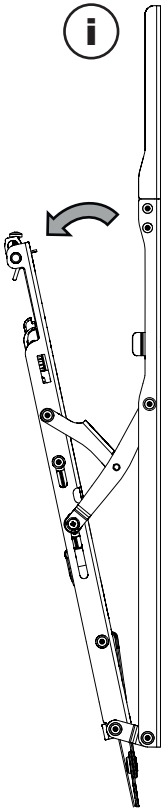

Extend Arm

ii

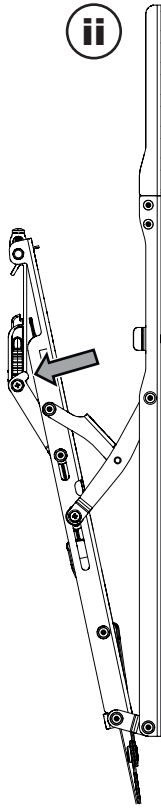

Extend Catch

iii

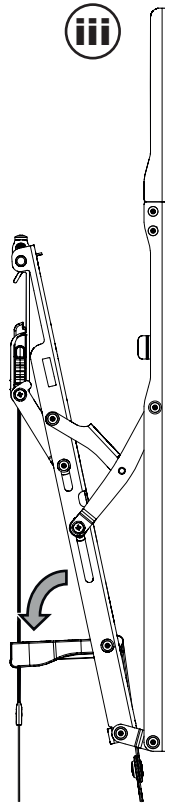

Extend Stand

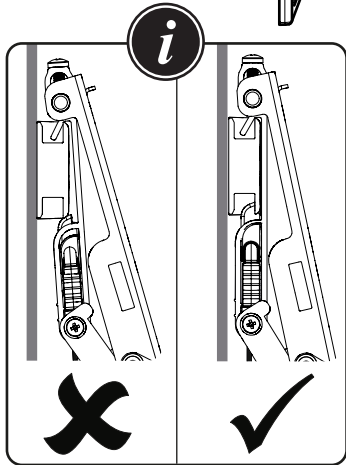
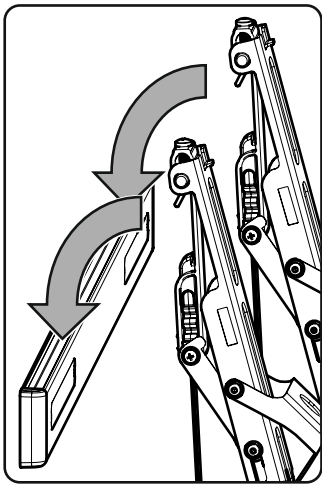

If the catch doesn't click into place when you connect your TV, pull the top of your TV forward to seat it correctly.

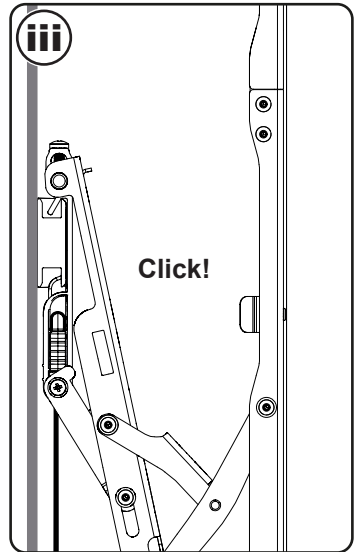
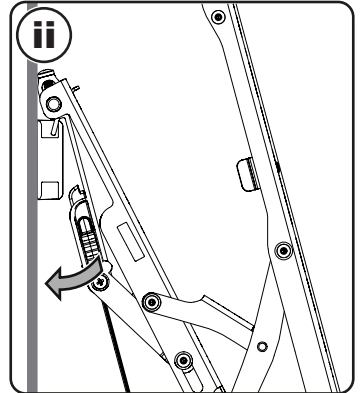
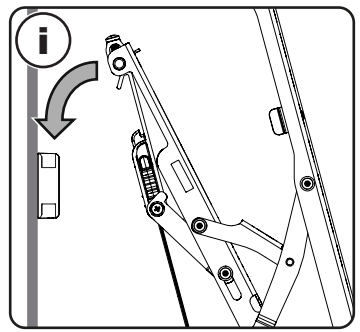

When the catch has clicked into place beneath the wall bracket your TV will be fully secured to the wall. You cannot accidentally unhook your TV.

**9**

## Hide the TV Release Cords

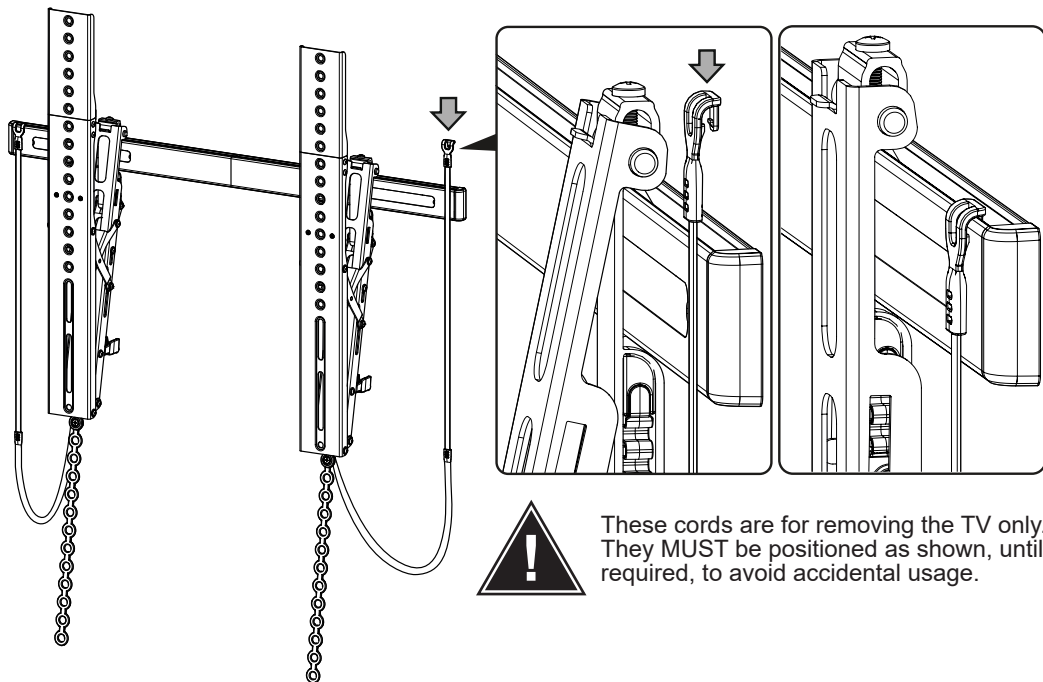
**10**

## Return the TV to the Wall

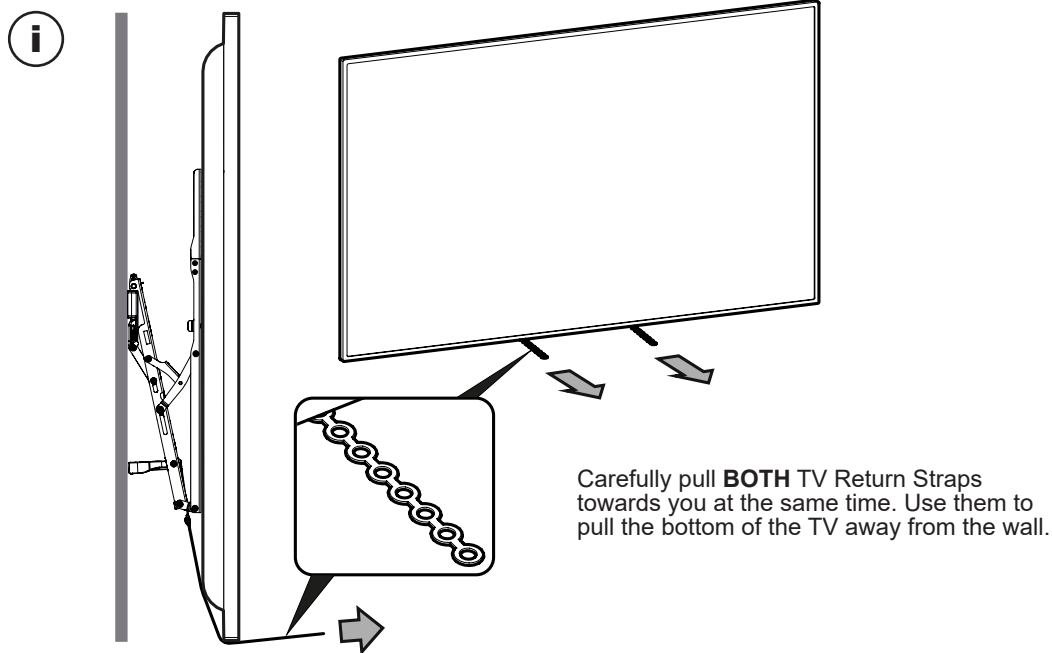



ii

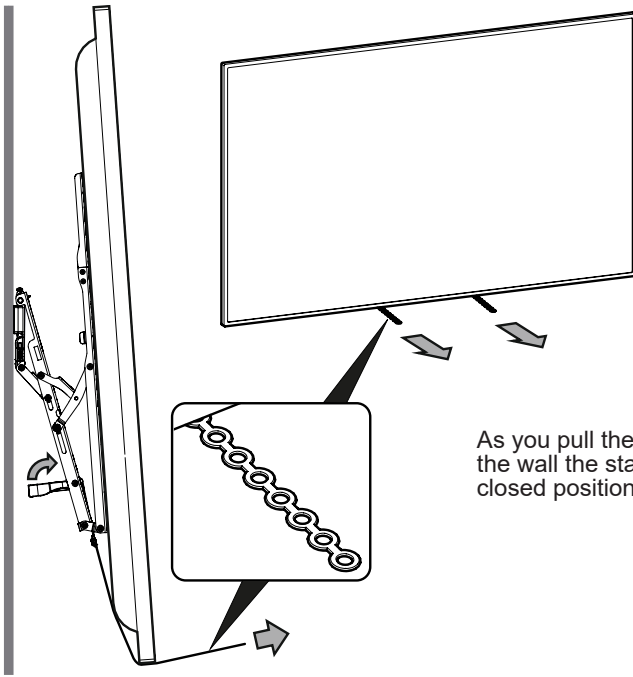

As you pull the bottom of the TV away from the wall the stands will click back into their closed position.

iii

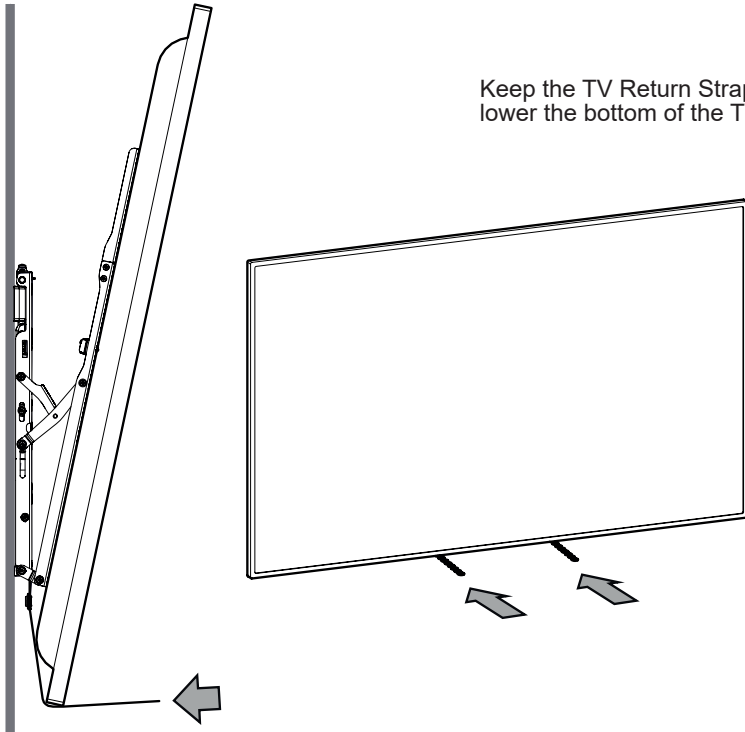

Keep the TV Return Straps tight and gently lower the bottom of the TV to the wall.

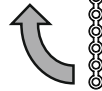
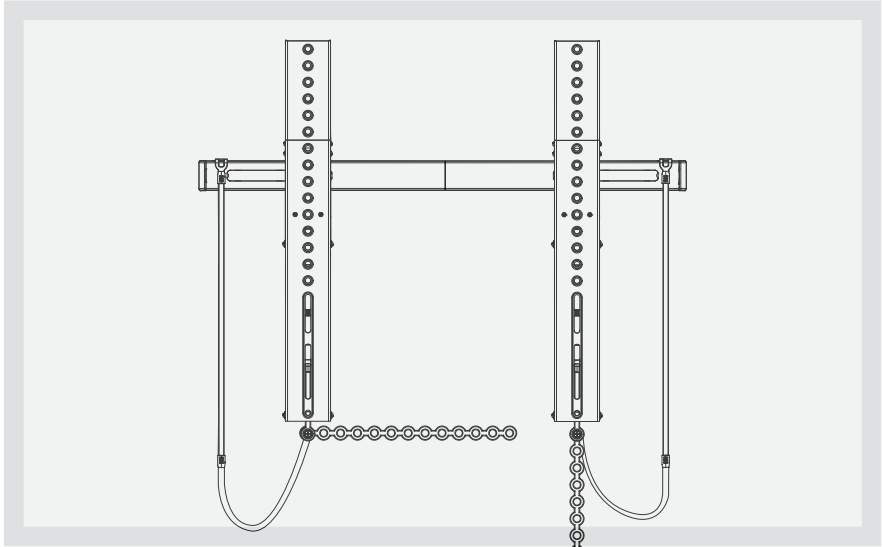
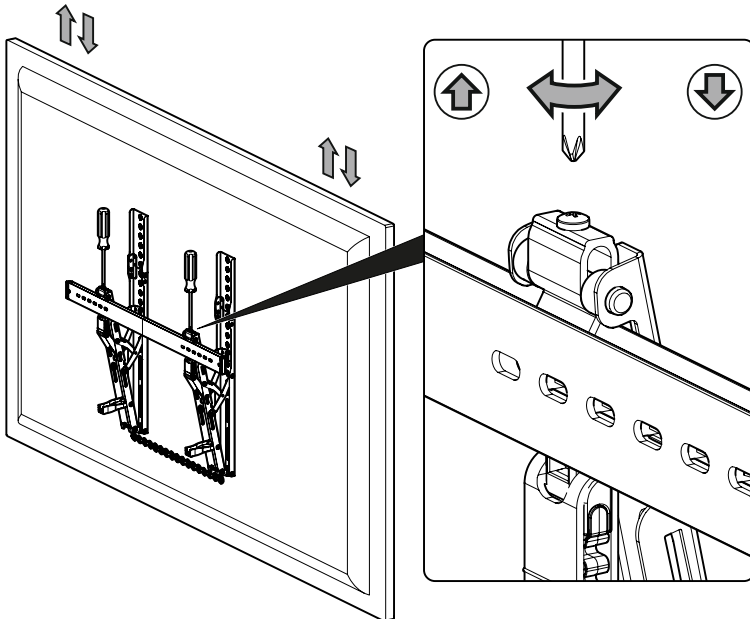
**11****Hide the TV Return Straps****TV Levelling (optional)**

## Adjust Tilt Resistance (optional)

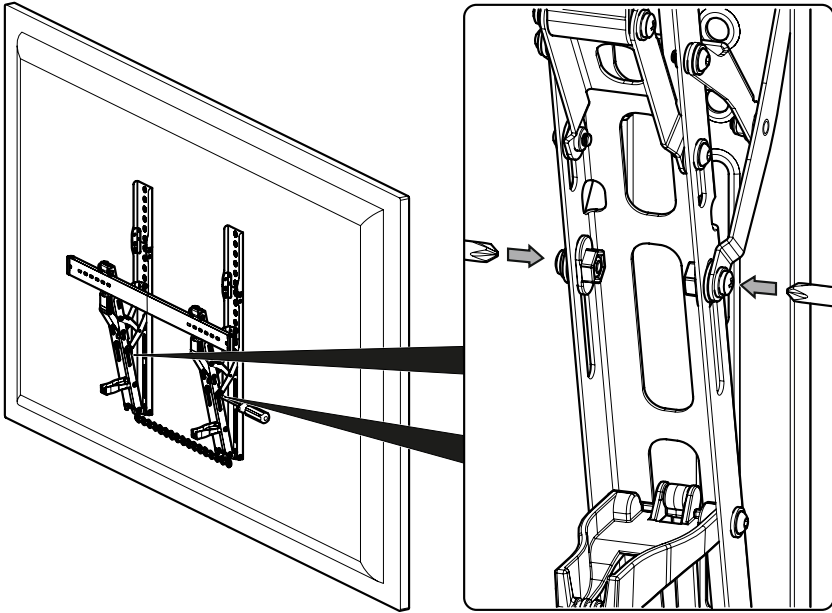

Adjust screws to achieve perfect tilt resistance if required. Ensure all screws are adjusted equally. You may need to remove the TV from the wall to gain easy access to the screws.

## The installation of your TV Wall Mount is now complete.

The rest of this instruction leaflet is operation and adjustment advice for your TV Wall Mount. It is recommended that you keep these instructions in a safe place so you can refer to them at a later date if required.

Use in conjunction with your **Handy User Guide**.  
For future reference, you can store your Handy User Guide  
in the groove on the Wall Rail.

## Cable Access

i

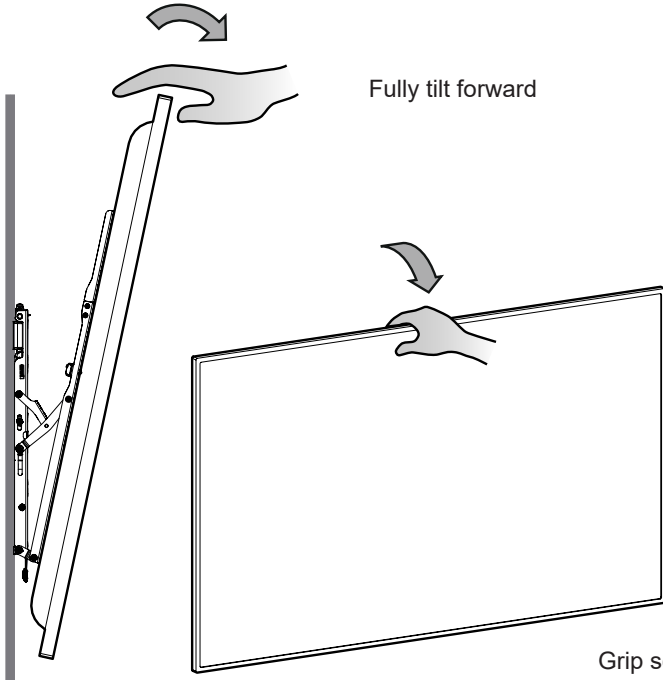

Grip screen centrally at top to tilt

ii

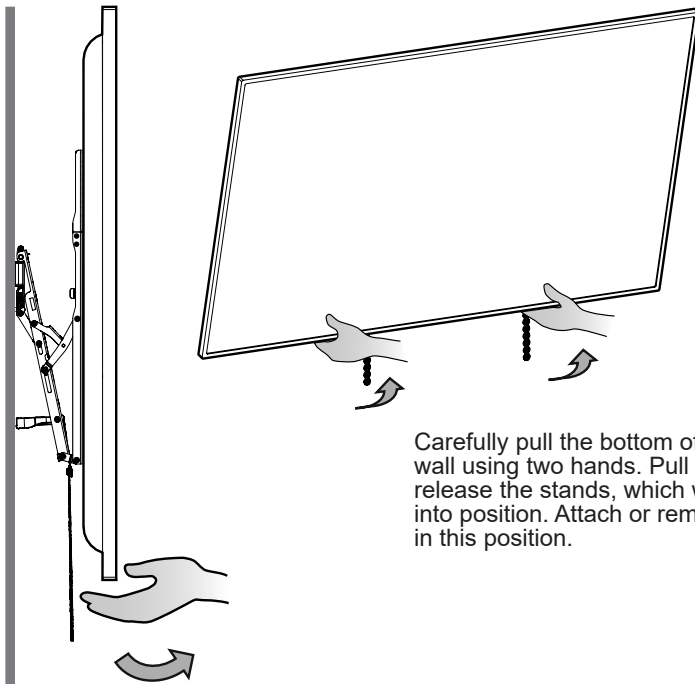

iii

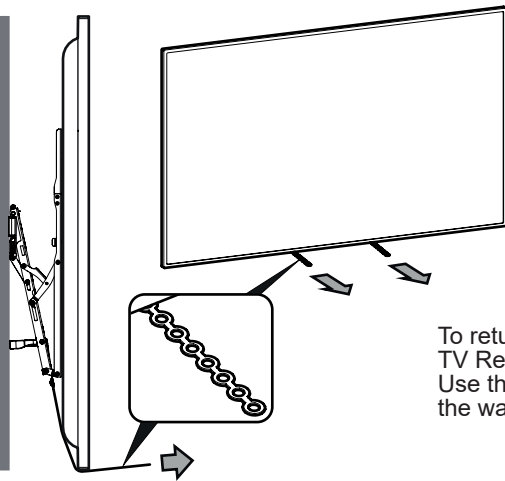

To return the TV to the wall, carefully pull **BOTH** TV Return Straps towards you at the same time. Use them to pull the bottom of the TV away from the wall.

iv

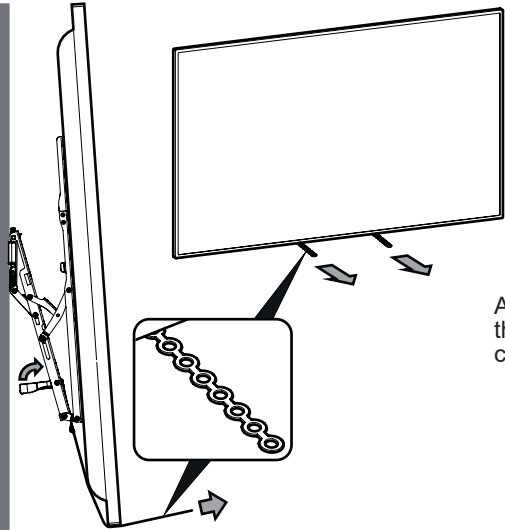

As you pull the bottom of the TV away from the wall the stands will click back into their closed position.

v

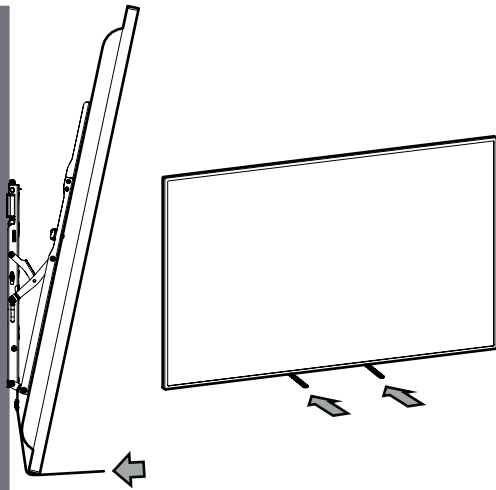

Keep the TV Return Straps tight and gently lower the bottom of the TV to the wall.

## To Remove the TV

i

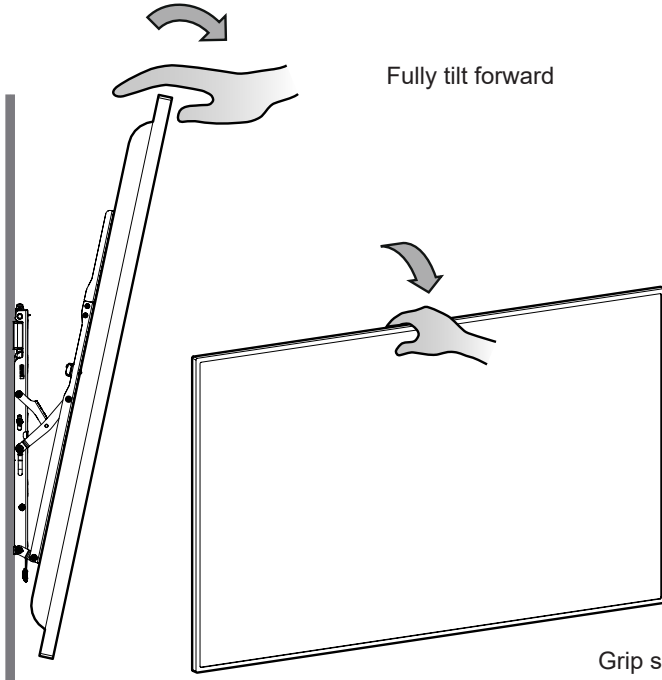

Grip screen centrally at top to tilt

ii

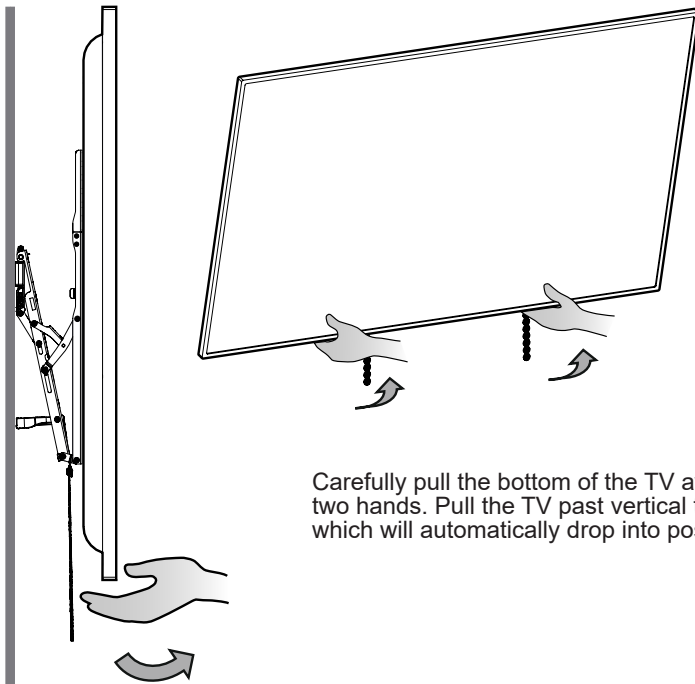



Unclip TV Release Cords from the Wall Rail.

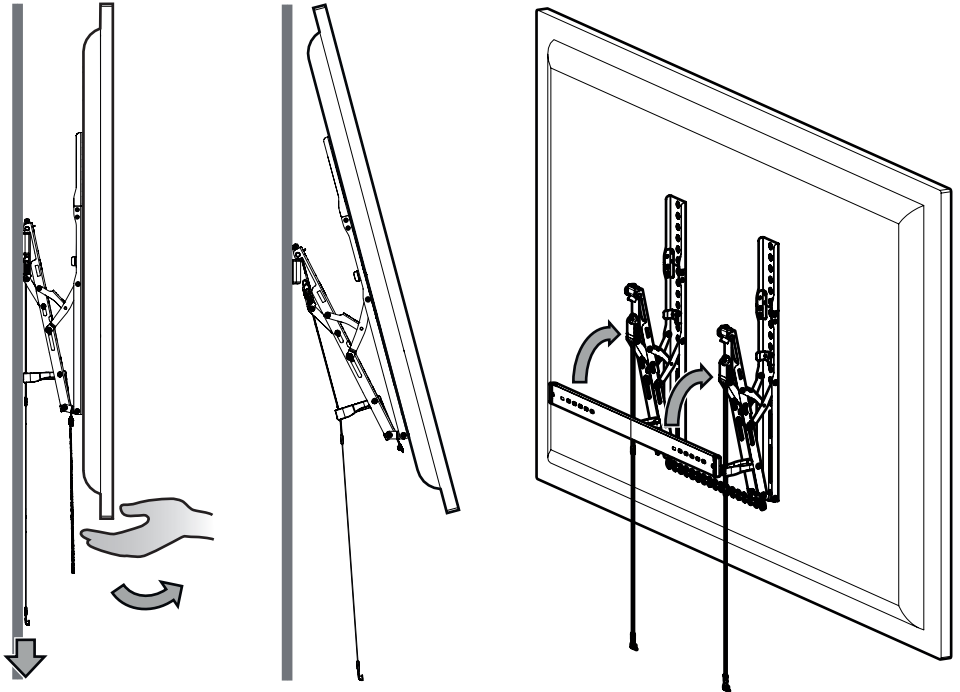
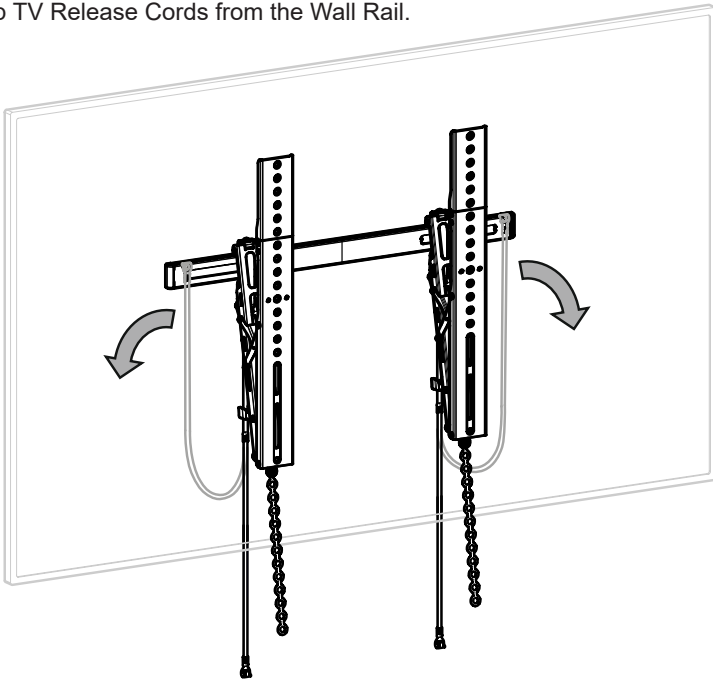

Pull both TV release cords at the same time to unlock the TV. Pull the bottom of the TV away from the wall so the catch cannot re-engage. Lift and remove the TV from the Wall Bracket.

## Tilt

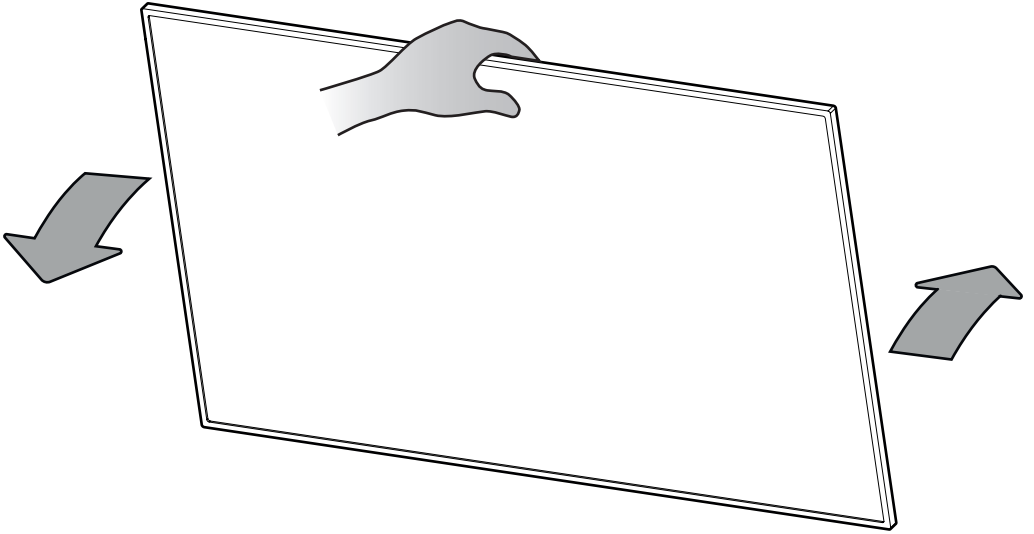

Grip screen centrally at top to tilt