

CPZL8601-C

English language / Langue française

Leaflet No. / Notice n° 466119 rev 00

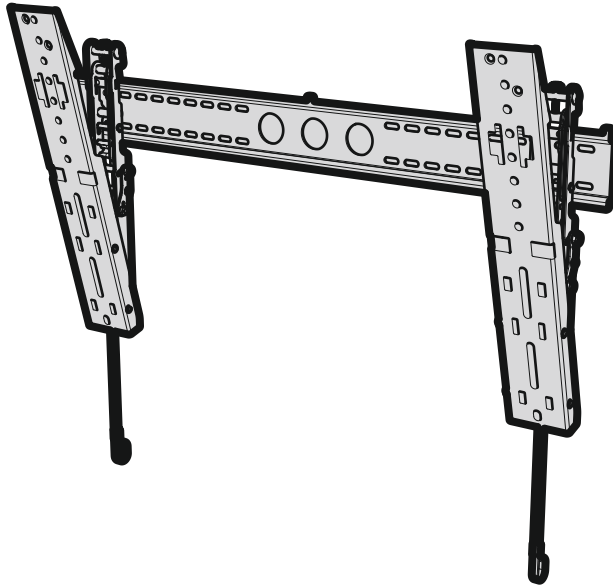

Read through **ALL** instructions before commencing installation.
If you have any questions about this product or issues with installation contact the customer services help line before returning this product to the store.



Lisez toutes les instructions avant de débiter l'installation.
Si vous avez des questions sur ce produit ou des problèmes d'installation, contactez l'assistance client avant de ramener le produit en magasin.



This bracket is intended for use with **90" Maximum** televisions weighing **Maximum 68kg (150lbs)**. Use with products heavier than maximum weights may result in instability causing possible injury.



Cette applique doit être utilisée pour des téléviseurs de **90" maximum** et pesant au **maximum 68kg (150lbs)**. L'utiliser avec des produits excédant le poids maximum peut causer de l'instabilité provoquant de possibles accidents.

CUSTOMER SERVICES HELP LINE NUMBER:
NUMÉRO DE L'ASSISTANCE CLIENT:

1-800 667 0808 (USA)



AVF Incorporated. 3187, Cornerstone Drive, Eastvale, CA 91752, USA

Assembly Overview
Vue d'ensemble de l'assemblage

Fit the TV Brackets
Fixer l'applique téléviseur

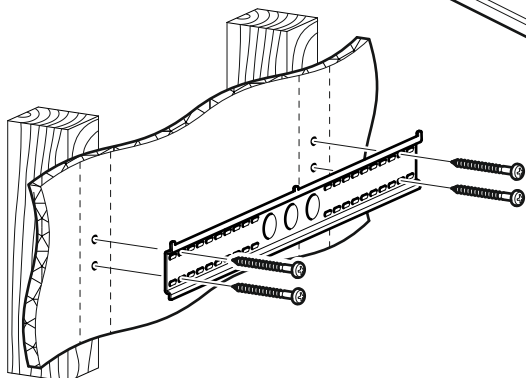
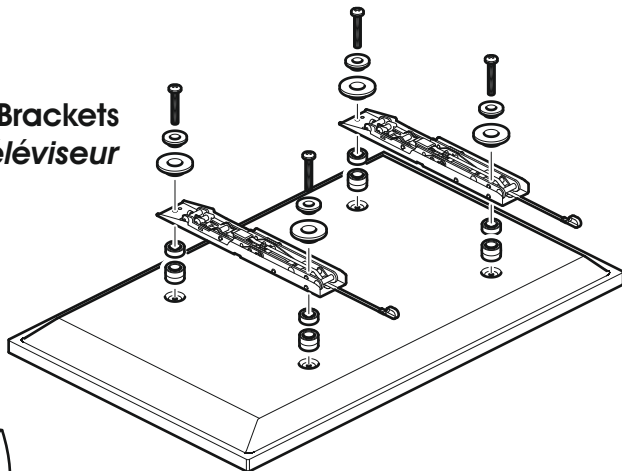

Fit the Wall Bracket
Fixer l'applique murale

Connect the TV
Connecter le téléviseur

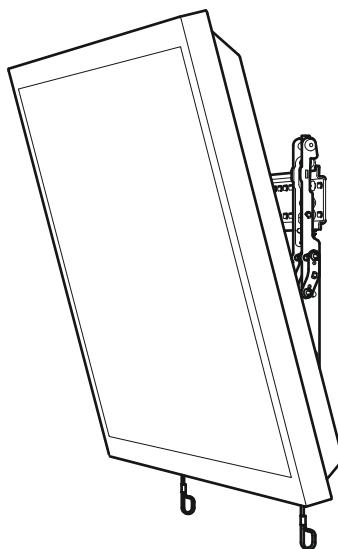
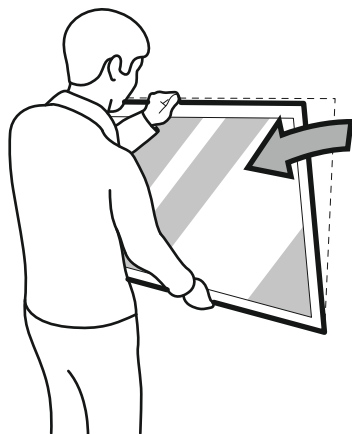

Tilt (if required)
Inclinaison (Si nécessaire)

Index

Index

1 Measure the TV fixing holes Width and Height
Mesurer la profondeur et la taille des trous de fixation

2 Preparing the TV Brackets
Préparer l'applique téléviseur

3 Fitting the TV Brackets
Installer l'applique téléviseur

4 Determine your TV position
Déterminez la position de votre télé

5 Fitting the Wall Bracket
Installer l'applique murale

6 Connecting the TV
Connecter le téléviseur

Retain all packaging in case the bracket needs to be returned.
Contents may vary from photography/ Illustrations.

You will not need all these parts, so expect there to be some left over depending upon the specification of your TV.

This product is intended for indoor use only. Use of this product outdoors could lead to failure and personal injury.

It is the responsibility of the installer to ensure that the mounting wall is of a suitable standard and void of any services (eg gas, electricity, water etc). AVF accept no responsibility for any damage or loss caused by installing this product in a sub standard wall.

Conserver les emballages si l'applique a besoin d'être ramenée.

Les contenus peuvent varier de la photographie/illustrations.

Vous n'aurez pas besoin de toutes ces pièces, attendez-vous donc à ce qu'il reste des pièces selon les caractéristiques de votre téléviseur.

Ce produit est à utiliser à l'intérieur uniquement. Utiliser ce produit à l'extérieur causera des défaillances et de possibles accidents.

Il est de la responsabilité de l'installateur de s'assurer que les murs soient aux critères requis et vides de tout câblage (ex : gaz, électricité, eau etc...)

AVF n'acceptera aucune responsabilité pour tout dommage ou perte causée par l'installation du produit dans un mur en deçà de ces critères.

Tools Recommended
Outils recommandés

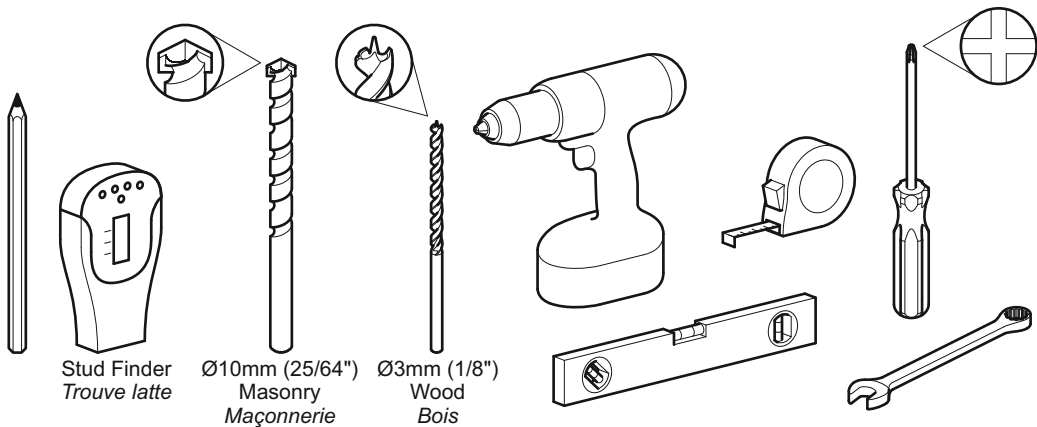

Boxed Parts
Pièces empaquetées

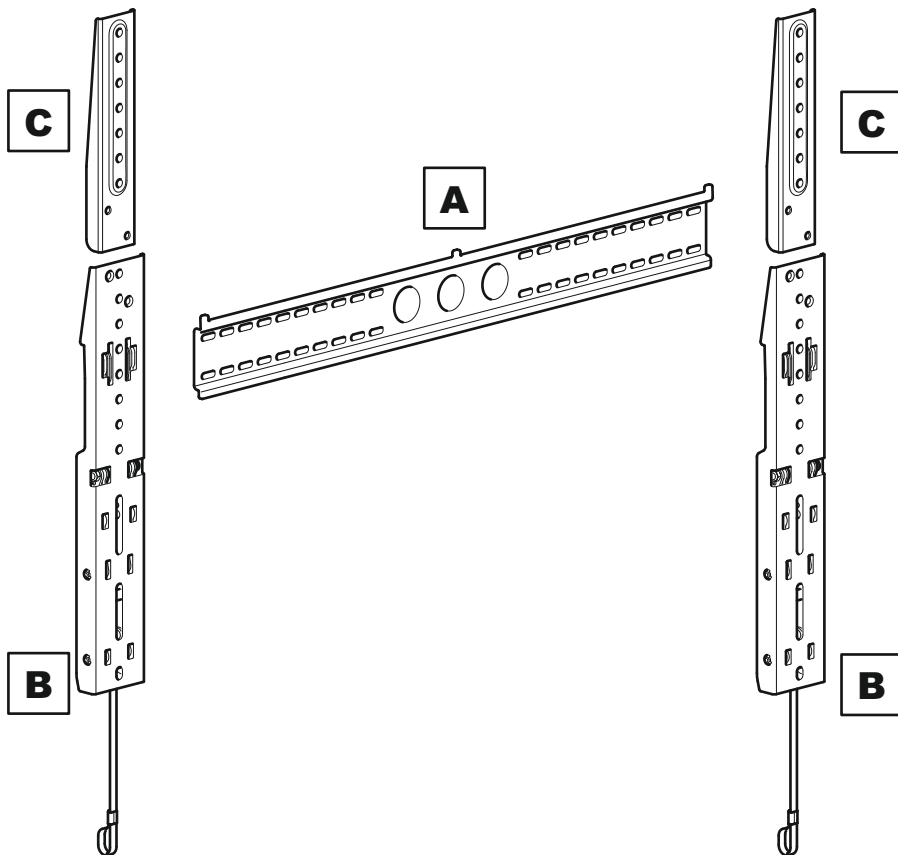

TV Screws, Reducers and Spacers

Vis TV, réducteurs et séparateurs

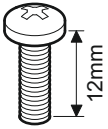

M4

D1 x4

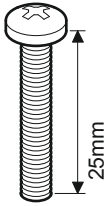

M4

D2 x4

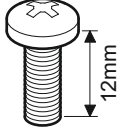

M5

D3 x4

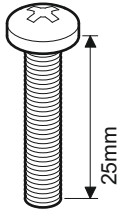

M5

D4 x4

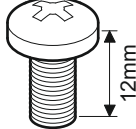

M6

D5 x4

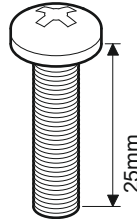

M6

D6 x4

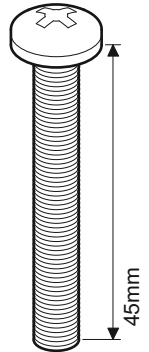

M6

D7 x4

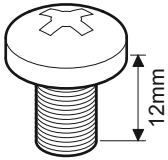

M8

D8 x4

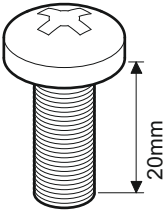

M8

D9 x4

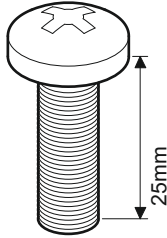

M8

D10 x4

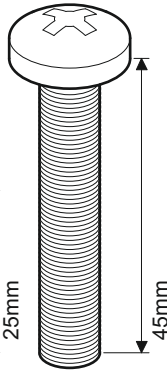

M8

D11 x4



E1 x4



E2 x4



F1 x12

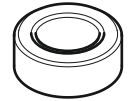

F2 x4

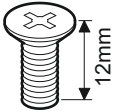

M5

G x4



H x4



I x4



J x4



K x4



L

1

Measure the TV fixing holes Width and Height
Mesurer la profondeur et la taille des trous de fixation

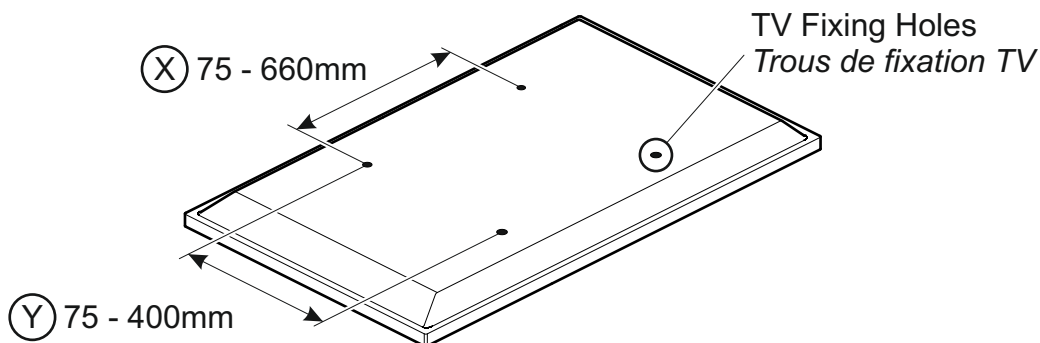

If width (X) is greater than 660mm or height (Y) greater than 400mm
 STOP installation now and contact the customer help line



Si la largeur (X) est plus large que 660mm et la hauteur (Y) plus grande que 400mm, **ARRÊTEZ** l'installation immédiatement et contactez l'assistance client

You are provided with 4 diameters of TV fixing screws, **M4**, **M5**, **M6** and **M8**. Determine the screw diameter that fits and remember for step 3.
 4 diamètres de vis TV vous sont fournis, **M4**, **M5**, **M6**, et **M8**. Déterminez le diamètre de la vis qui convient et mémorisez- le pour l'étape 3.

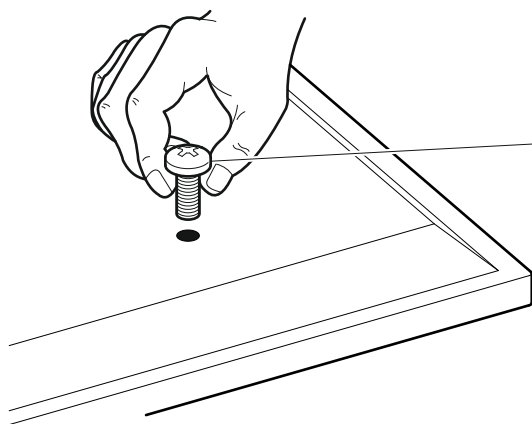

M4 =	D1/D2
M5 =	D3/D4
M6 =	D5-D7
M8 =	D8-D11

2

Preparing the TV Brackets Préparer l'applique téléviseur

To ensure maximum tilt is possible after installation you will need to ensure that your TV does not clash with the wall.

Pour assurer qu'une inclinaison maximum est possible après l'installation il faudra vous assurez que votre téléviseur ne frotte pas contre le mur.

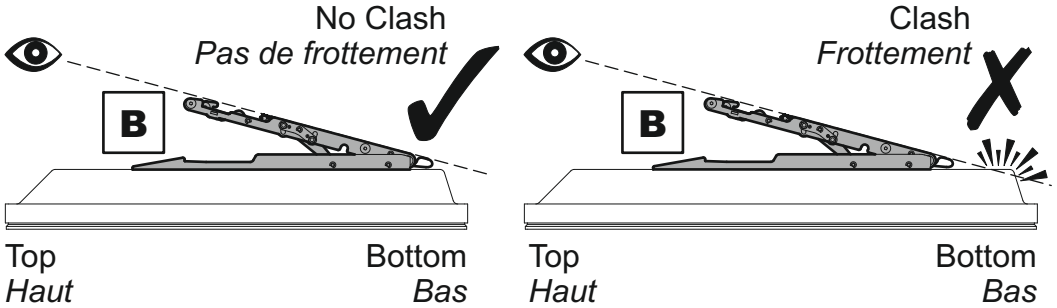

If a clash is observed you will need to use adaptors **C** to position the TV Brackets **B** closer to the bottom of the TV to achieve maximum tilt.

*Si un conflit est observé, vous aurez besoin d'utiliser les adaptateurs **C** pour positionner les supports **B** plus près du fond de la TV pour atteindre inclinaison maximale.*

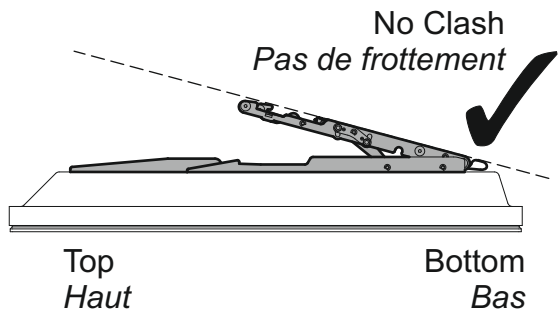
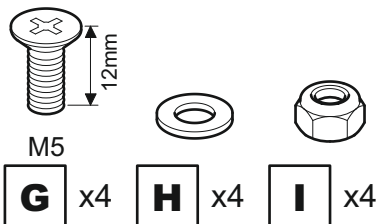
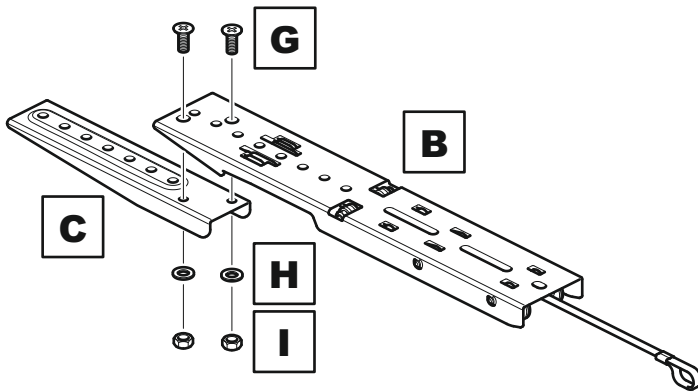

3

Fitting the TV Brackets Installer l'applique téléviseur

No Spacers / Pas de séparateur

For Tvs with flat/unobstructed back
*Pour des téléviseurs aux dos plats
et non obstrués.*

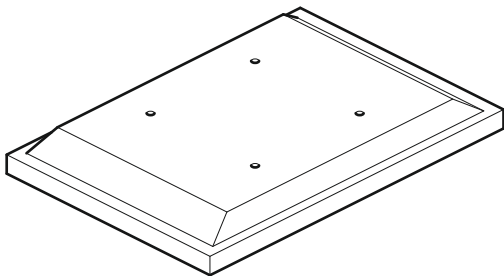

Spacer / Séparateurs **F1/F2**

For Tvs with irregular/obstructed back
*Pour des téléviseurs aux dos
irréguliers et non obstrués.*

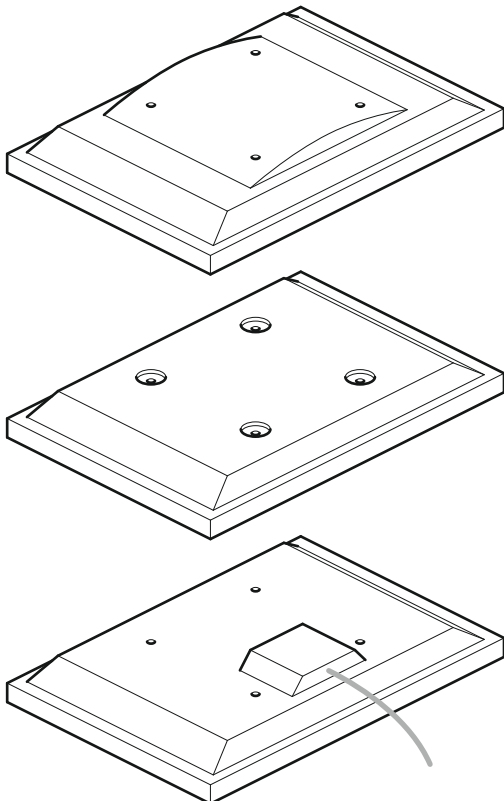

WARNING / AVERTISSEMENT

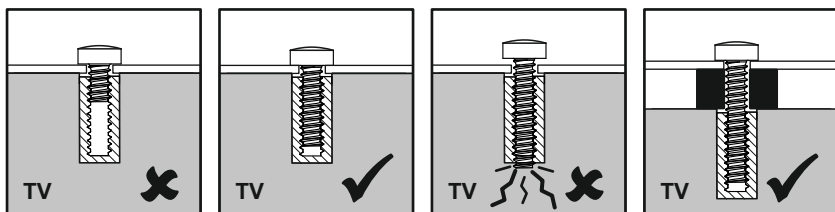

After completing step 3 you will have fittings left over, please keep for future reference

Après avoir complété l'étape 3 il vous restera des pièces d'assemblage, conservez-les.



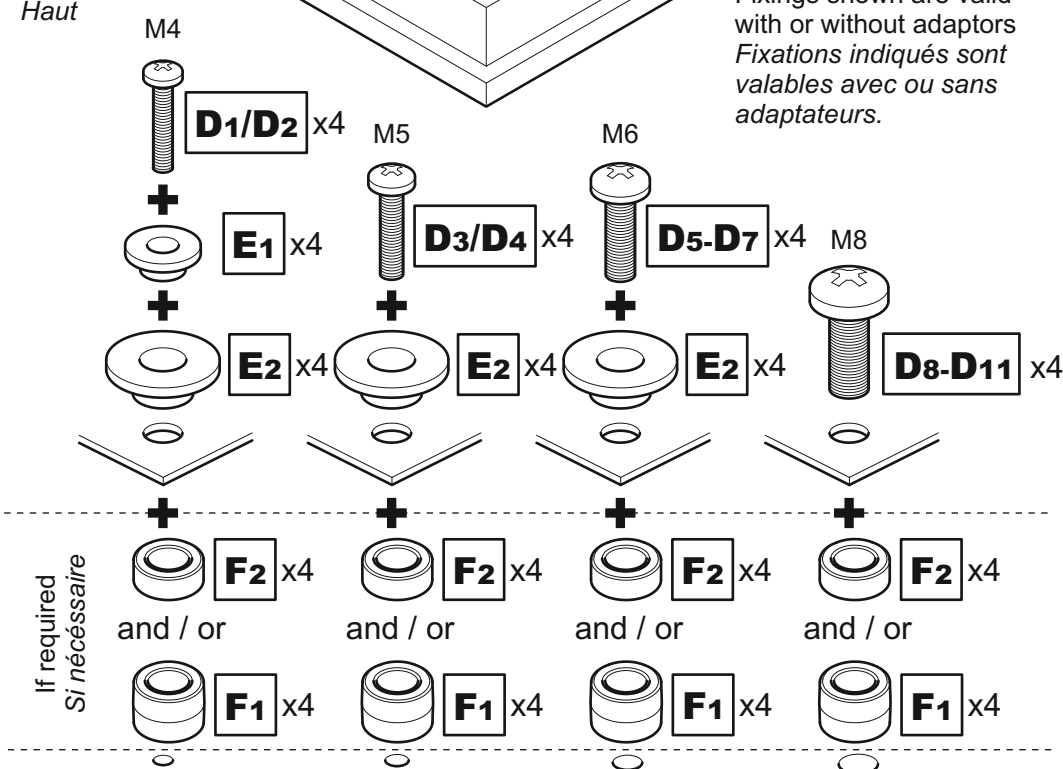
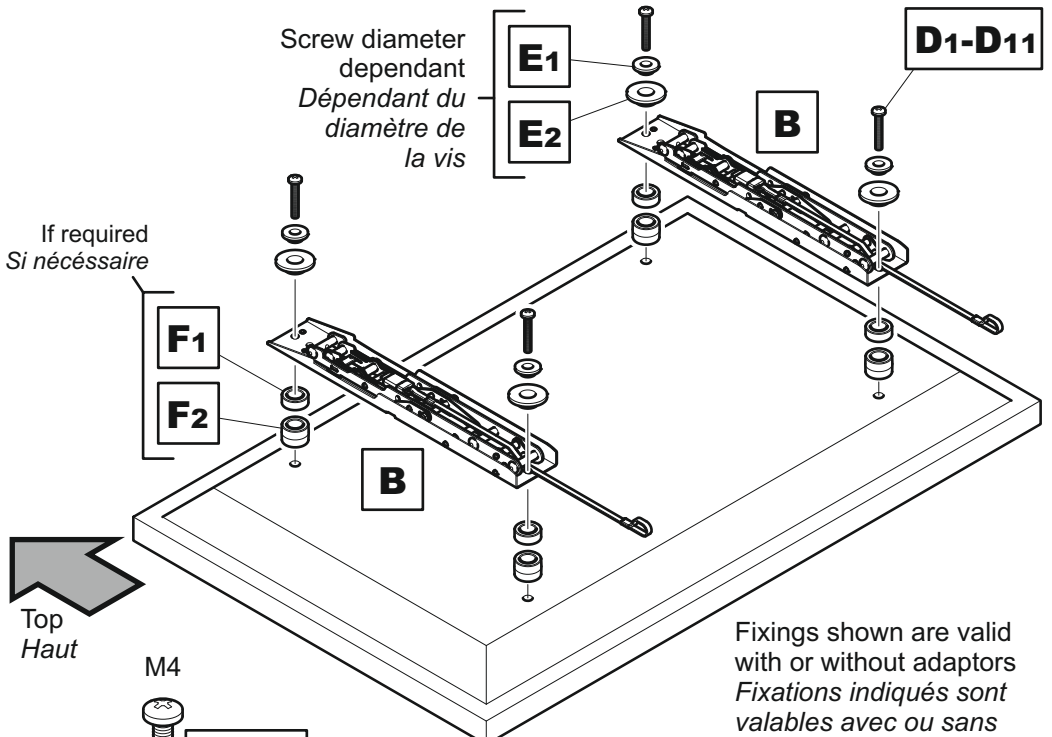

Attach the bracket to the back of your TV using suitable screw, reducer and spacer combinations
Attachez l'applique au dos de votre téléviseur en utilisant une combinaison de vis, de séparateurs et de joints adaptés

4

Determine your TV position Déterminez la position de votre télé

Joining template L to part A will give you a guide that represents the height and center of YOUR TV so you can position YOUR TV perfectly and know exactly where to drill your wall.
Joindre le gabarit L à la pièce A vous fournira un guide pour figurer la hauteur et le centre de VOTRE TÉLÉ, afin que vous puissiez la positionner parfaitement et de savoir exactement où percer dans votre mur.

i Attach **A** to **B**
Joindre A à B

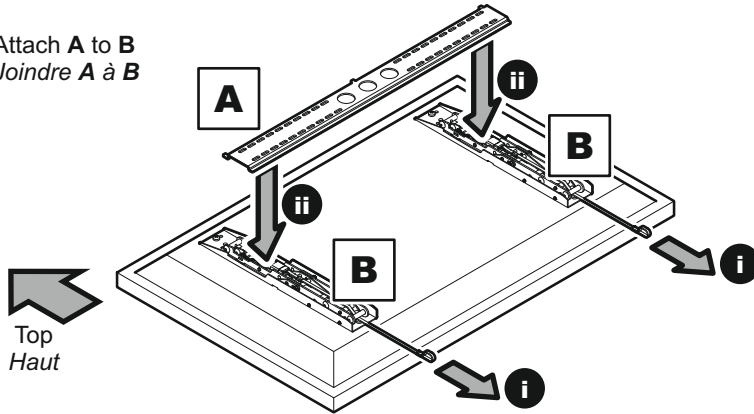

ii Align template L with the top of your TV and cut so it is flush with the bottom of your TV and stick in position. Ensure template L is in the center of your TV.
Alignez le gabarit L avec le dessus de votre TÉLÉ, coupez pour qu'il arrive juste avec le bas de votre TÉLÉ et collez-le en place. S'assurer que le gabarit L soit au centre de votre TÉLÉ.

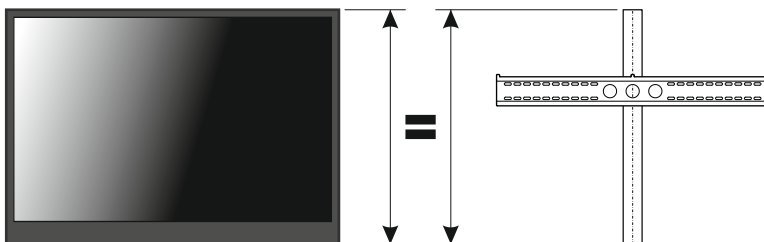
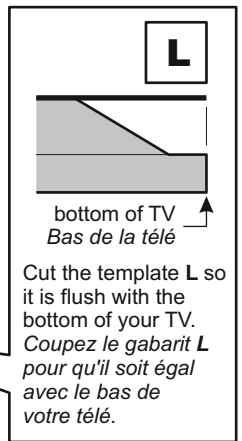
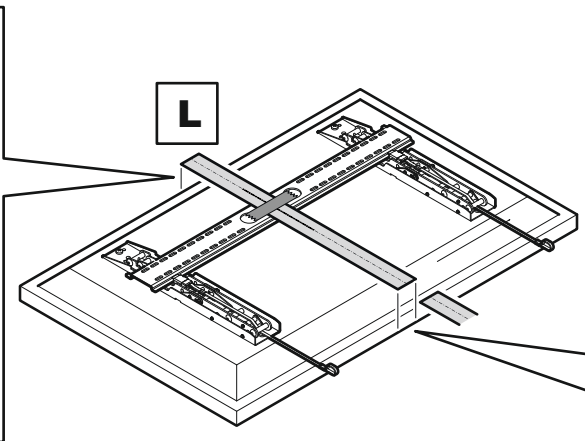
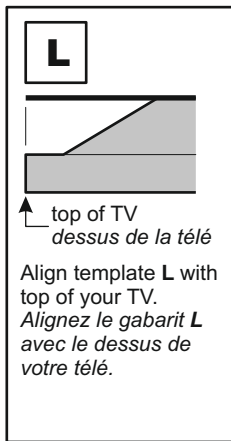

iii

Remove template **L** and part **A** from the back of your TV before you continue.
*Enlever le gabarit **L** et la pièce **A** de l'arrière de votre TÉLÉ, avant de continuer.*

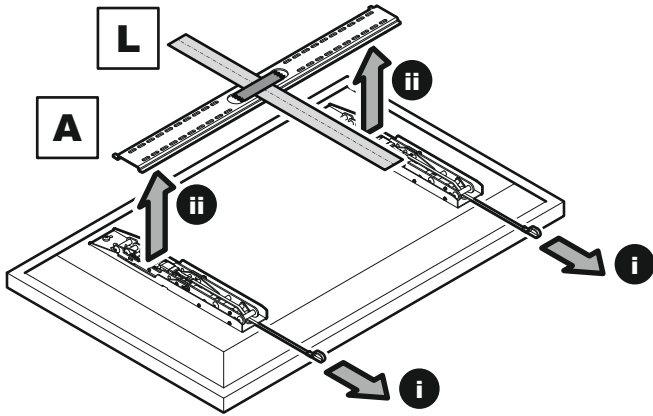

iv

Use template **L** and part **A** to determine the position of your TV on the wall.
*Utiliser le gabarit **L** et la partie **A** pour déterminer la position de votre TÉLÉ sur le mur.*

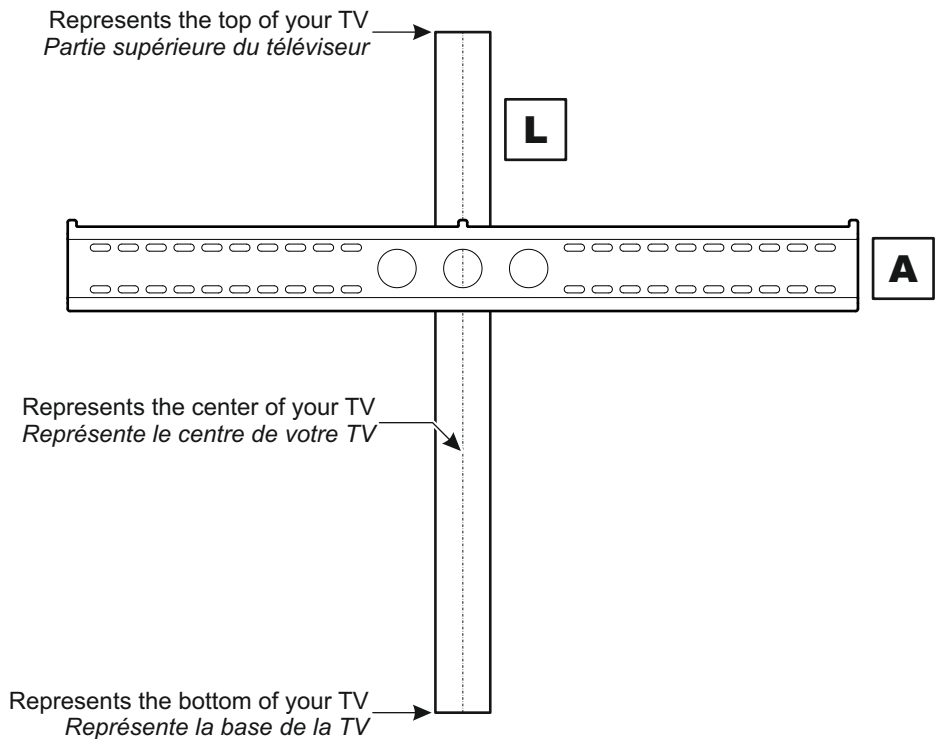

5

Fitting the Wall Bracket
Installer l'applique murale

Solid Wall / Mur solide

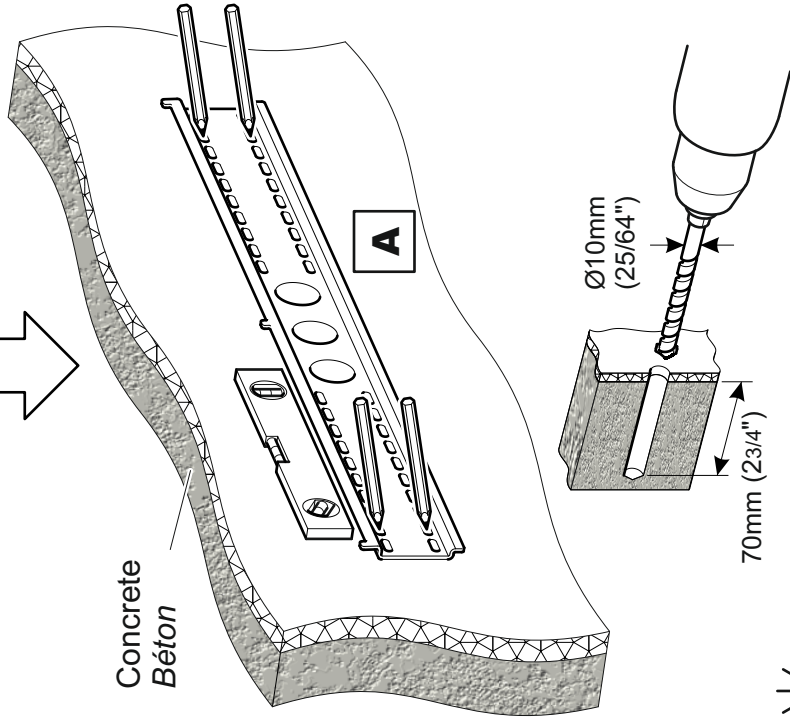

Remove dust from hole
Retirez la poussière du trou

Wood Stud / latte de bois

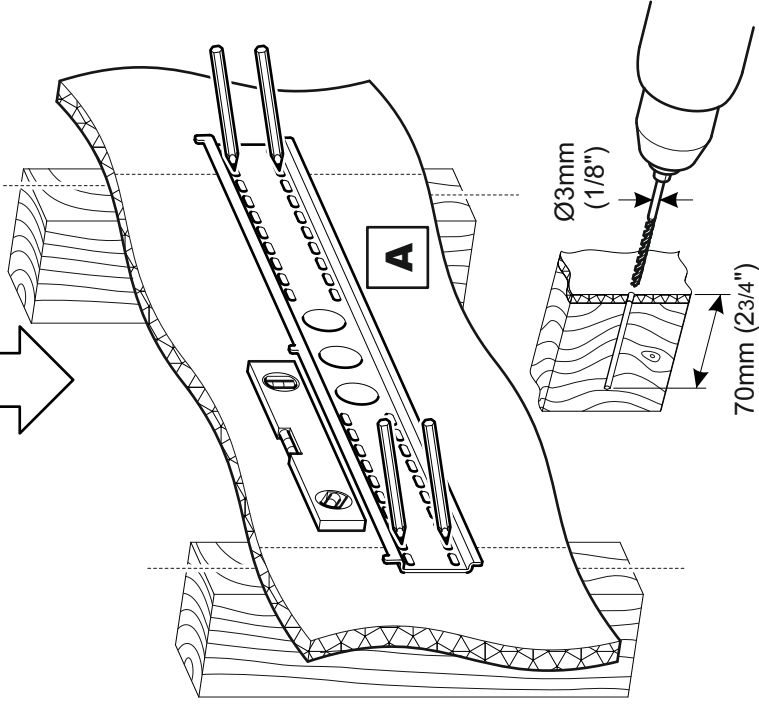

Ensure bracket is in the centre of the wood stud
Assurez-vous que l'applique est au centre de
la latte de bois



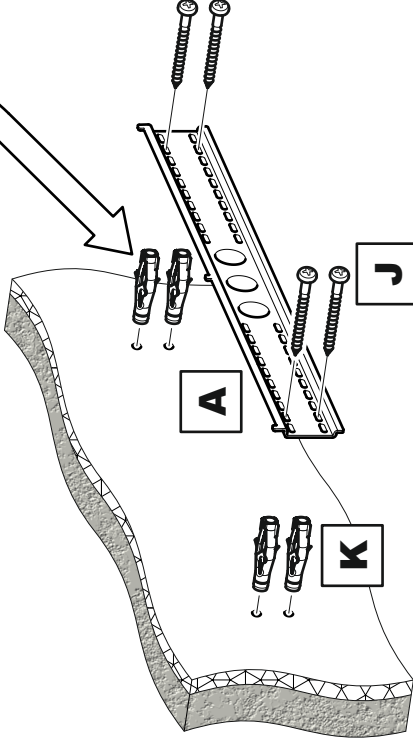
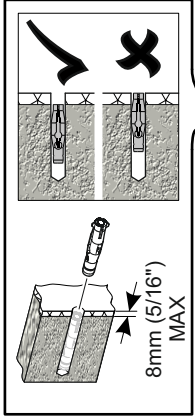
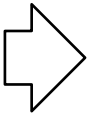

Lubricate screw
thread with soap
*Lubrifiez le pas
de vis avec du
savon*



DO NOT over tighten screws
Tighten screws by hand only
*Ne serrez pas trop les vis.
Visser à la main seulement*



x4



x4

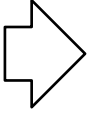

Lubricate screw
thread with soap
*Lubrifiez le pas
de vis avec du
savon*

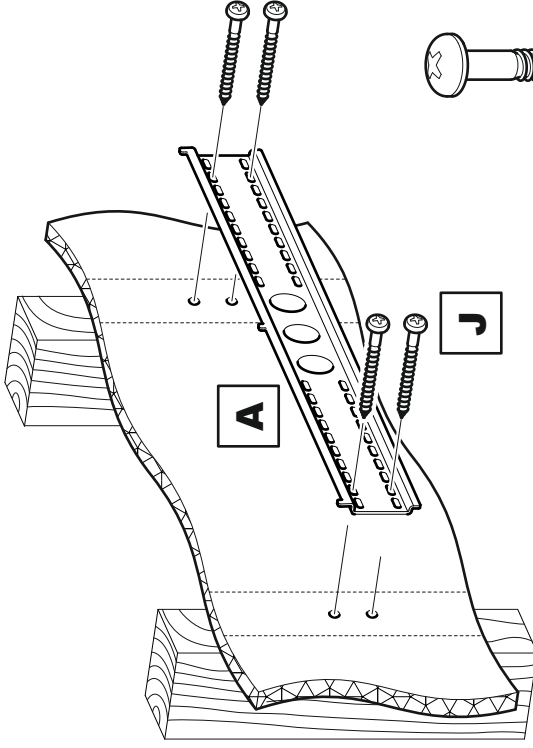

DO NOT over tighten screws
Tighten screws by hand only
*Ne serrez pas trop les vis.
Visser à la main seulement*

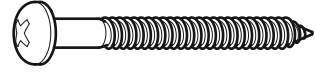

x4



6

Connecting the TV Connecter le téléviseur

Attaching
Attacher

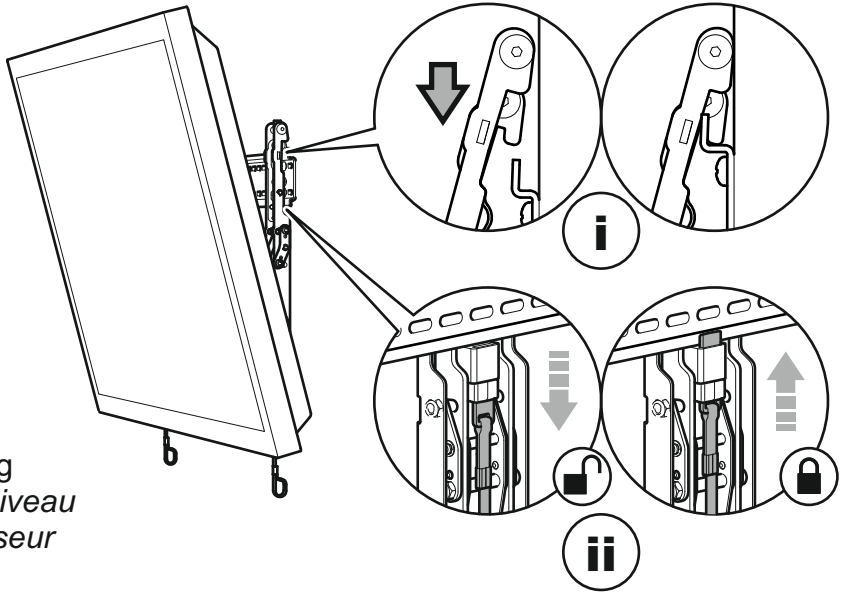

TV Levelling
Mettre au niveau
votre téléviseur

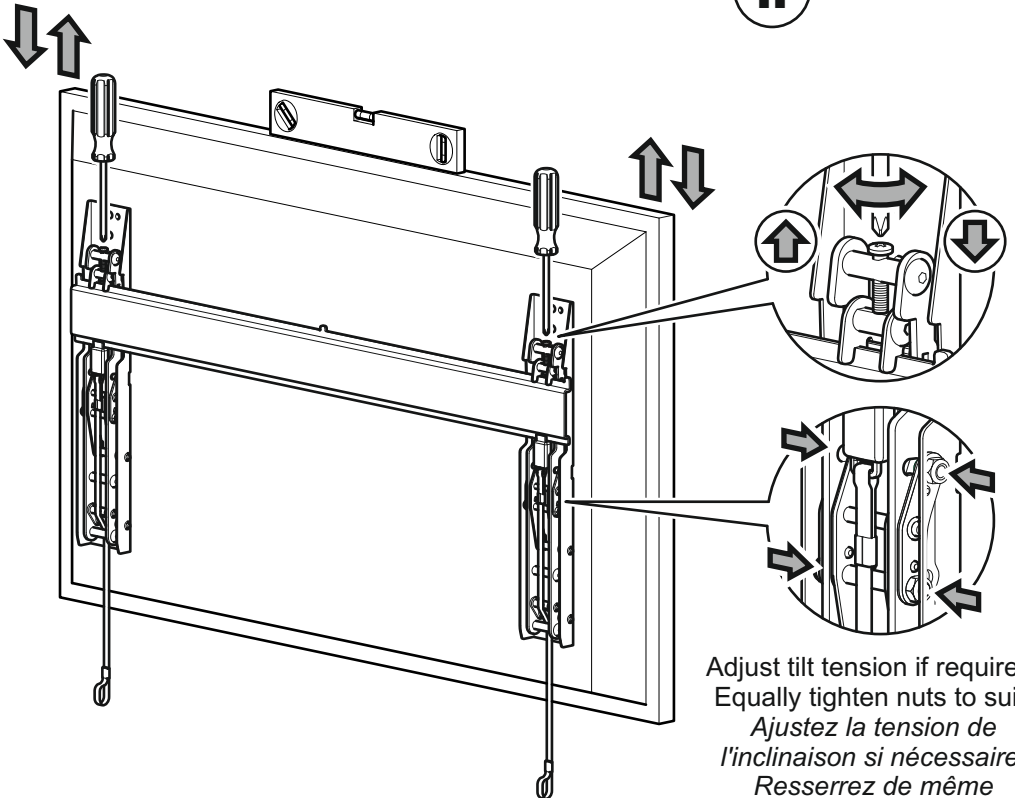

Adjust tilt tension if required.
Equally tighten nuts to suit.
*Ajustez la tension de
l'inclinaison si nécessaire.
Resserrez de même
façon les écrous.*