

RZL4601-E

English language/ Idioma Español

Leaflet No. / No. de folleto **464078** rev 01

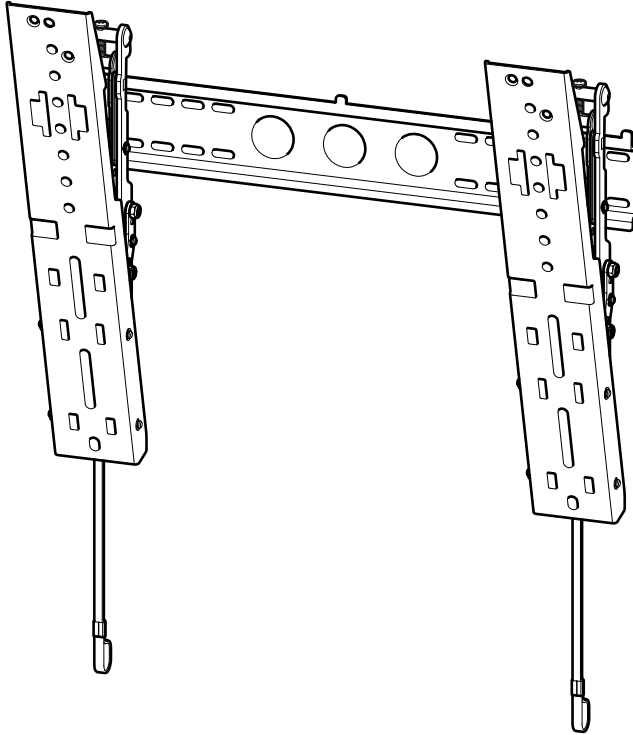

*Read through **ALL** instructions before commencing installation.
If you have any questions about this product or issues with installation contact the customer services help line before returning this product to the store.*



*Lea todas las instrucciones antes de comenzar la instalación.
Si tiene alguna pregunta sobre el producto o problemas con la instalación.
llame a la línea de servicio al consumidor antes de devolverlo.*

**CUSTOMER SERVICES HELP LINE NUMBER:
NUMERO DE SERVICIO DE ATENCION AL CLIENTE:**

1-800 601 8450 (USA)

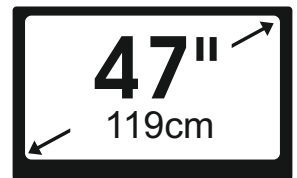

Orbital Holdings Inc. 3187, Cornerstone Drive, Eastvale, CA 91752, USA.

Assembly Overview
Ensambladura General

Fit the TV Brackets
Fije el Soporte de TV

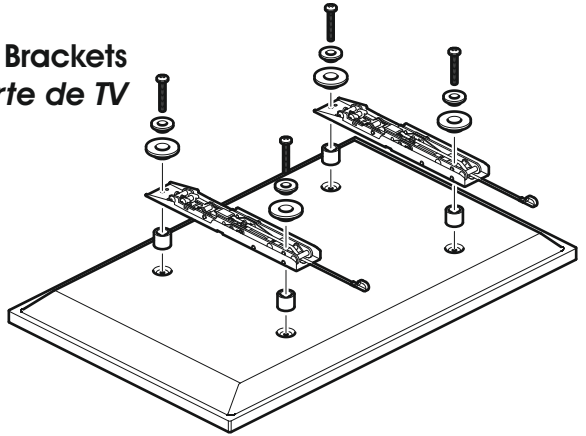

Fit the Wall Bracket
Fije el Soporte de Pared

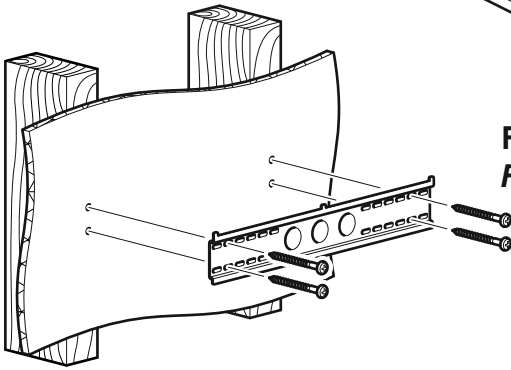

Connect the TV
Conecte la TV

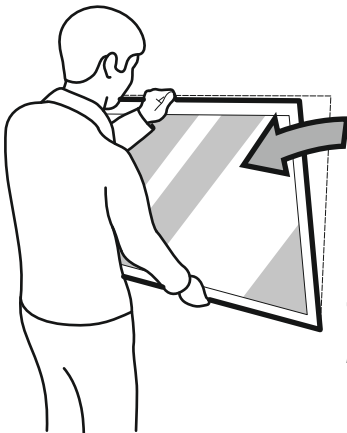
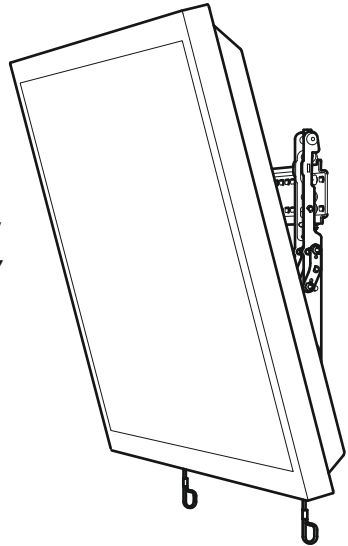

Tilt (if required)
Inclinación (Si necesario)

Index Índice

1 Measure the TV fixing holes Width and Height
Mida los orificios de su TV, lo ancho y lo alto

2 Preparing the TV Brackets
Prepare los Brazos del Soportes a su TV

3 Fitting the TV Brackets
Fije los Brazos del Soportes a su TV

4 Fitting the Wall Bracket
Fije la Placa a la Pared

5 Connect the TV
Conecte la TV

Retain all packaging in case the bracket needs to be returned.

Contents may vary from photography/ Illustrations.

You will not need all these parts, so expect there to be some left over depending upon the specification of your TV.

This product is intended for indoor use only. Use of this product outdoors could lead to failure and personal injury.

It is the responsibility of the installer to ensure that the mounting wall is of a suitable standard and void of any services (eg gas, electricity, water etc).

AVF accept no responsibility for any damage or loss caused by installing this product in a sub standard wall.

Conserve todos los envasados en caso de que el soporte tenga que ser devuelto.

El contenido puede variar de la fotografía / ilustración.

No necesitará todas estas partes, espere que sobren algunas según las especificaciones de su TV.

Este producto está diseñado para el uso en el interior solamente. El uso de este producto en el exterior podría llevar al fracaso y lesiones personales.

Es la responsabilidad del instalador de asegurarse de que la pared de montaje es de un nivel adecuado y carece de todo los servicios (gas, electricidad, agua, etc.).

AVF no acepta ninguna responsabilidad por cualquier daño o pérdida causada por la instalación de este producto en una pared inadecuada.

Tools Recommended
Herramientas recomendadas

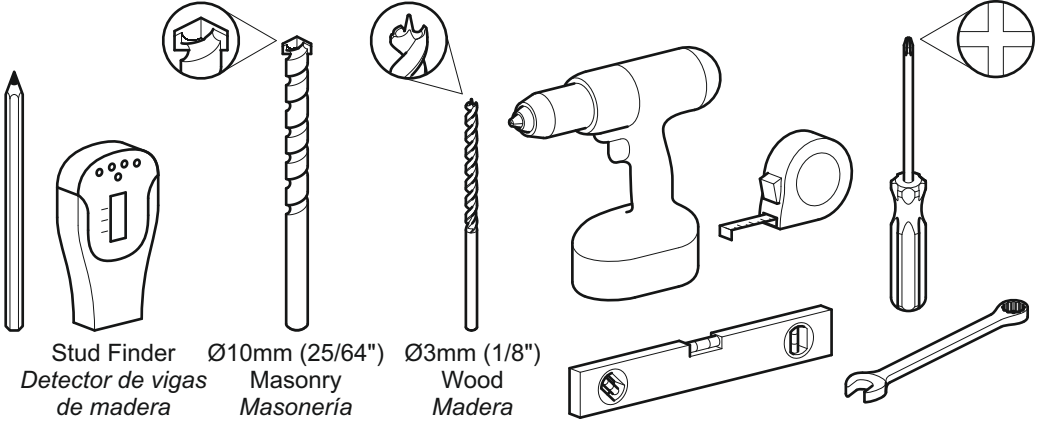

Boxed Parts
Piezas en la Caja

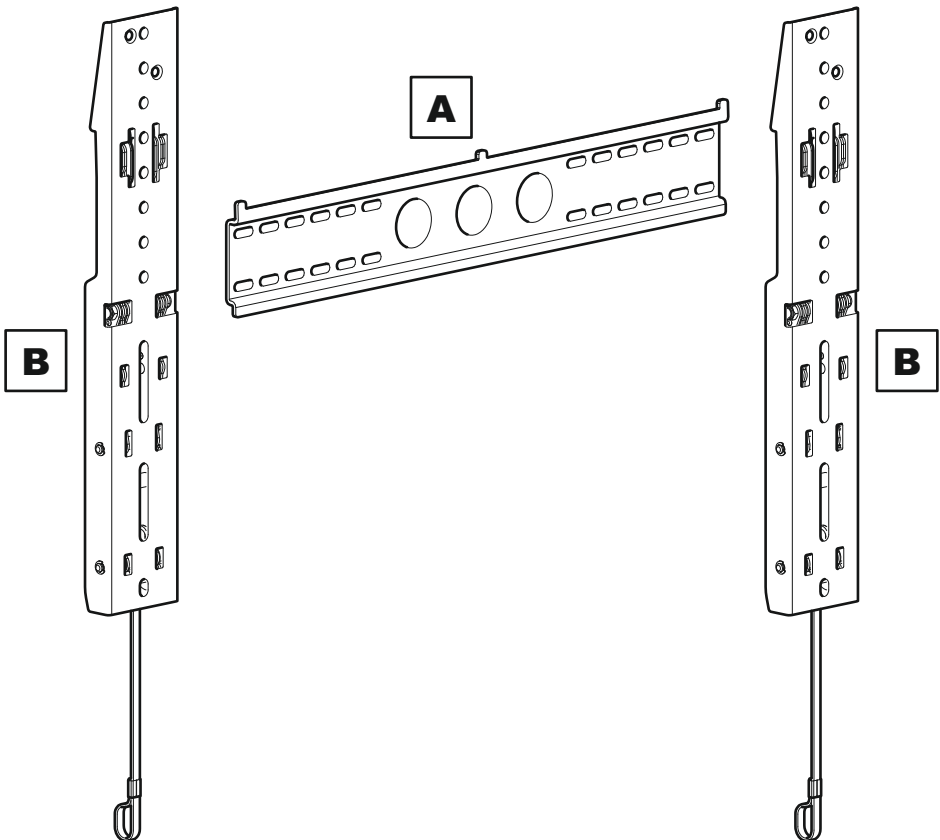

TV Screws, Reducers and Spacers

Tornillos, Reductores y Espaciadores para TV

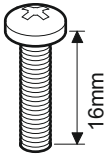

M4

E1 x4

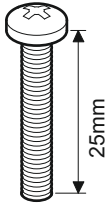

M4

E2 x4

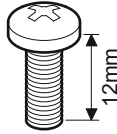

M5

E3 x4

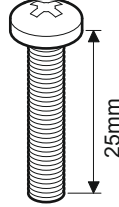

M5

E4 x4

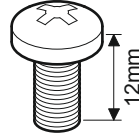

M6

E5 x4

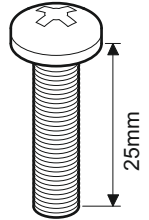

M6

E6 x4

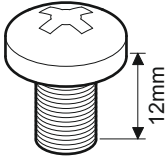

M8

E7 x4

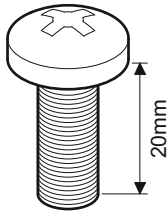

M8

E8 x4

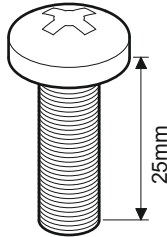

M8

E9 x4



G1 x4



G2 x4



F x4

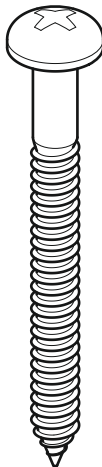

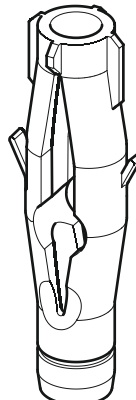

C x4

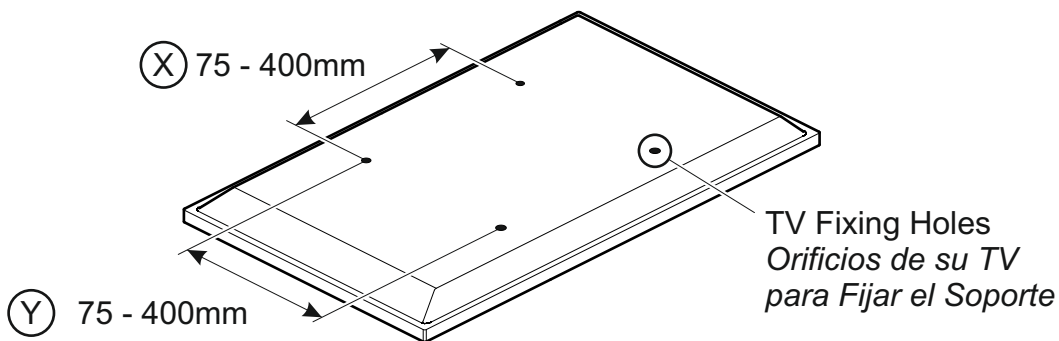

D x4

1 Measure the TV fixing holes Width and Height *Mida los orificios de su TV, lo ancho y lo alto*



 If width (X) is greater than 400mm or height (Y) greater than 400mm
STOP installation now and contact the customer help line

 Si la anchura (X) es mayor que 400mm o la altura de (Y) es mayor que 400mm **DETENGA** la instalación inmediatamente y póngase en contacto con la línea de ayuda al cliente

You are provided with 4 diameters of TV fixing screws, **M4**, **M5**, **M6** and **M8**. Determine the screw diameter that fits and remember for step 3.
*Se le proporciona con 4 diámetros de tornillos de fijación para su TV: **M4**, **M5**, **M6** y **M8**. Determine el diámetro del tornillo que le quede a su TV y recuérdelo para el paso 3.*

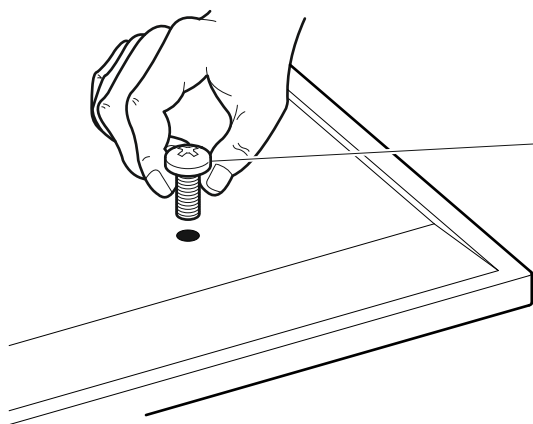

M4 =	E1/E2
M5 =	E3/E4
M6 =	E5/E6
M8 =	E7-E9

2

Preparing the TV Brackets

Prepare los Brazos del Soportes a su TV

To ensure maximum tilt is possible after installation you will need to ensure that your TV does not clash with the wall.

Para garantizar una inclinación máxima luego de la instalación, deberá asegurarse de que la TV no choque contra la pared.

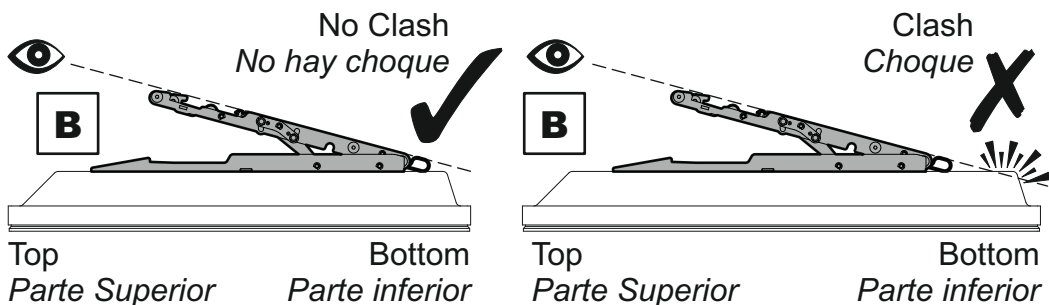

If a clash is observed you have 2 options:

Si observa alguna diferencia tiene 2 opciones:

Opción 1

Move Bracket **B** closer to the bottom of your TV

*Mueva el soporte **B** más cerca de la parte inferior del televisor*

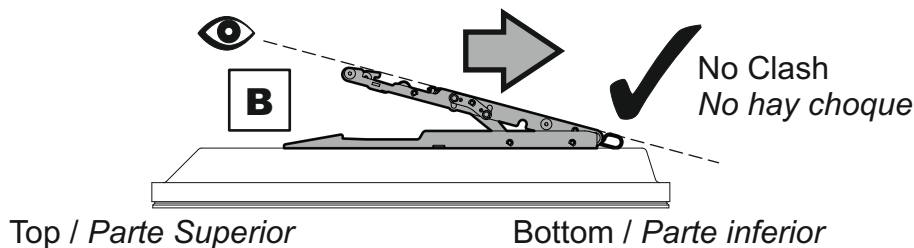

Opción 2

Use spacers **F** to raise Bracket **B**

*Utilice los espaciadores **F** para elevar el soporte **B***

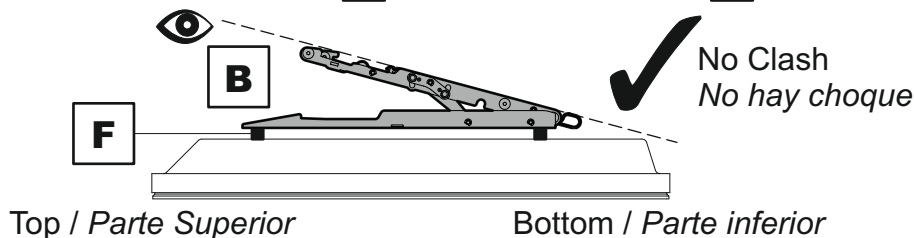

3**Fitting the TV Brackets****Fije los Brazos del Soportes a su TV****No Spacers
Sin espaciadores**

For TVs with flat/unobstructed back
 Para TVs con la parte posterior
 plana / sin obstáculos

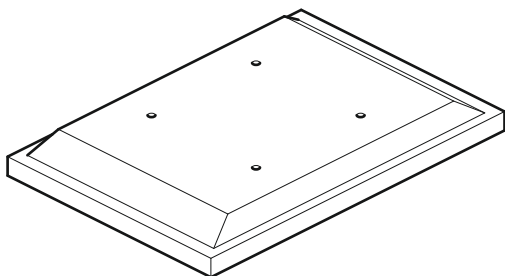
**Spacers
Espaciadores****F**

For TVs with irregular/obstructed back
 Para TVs con la parte posterior
 irregular / con obstáculos

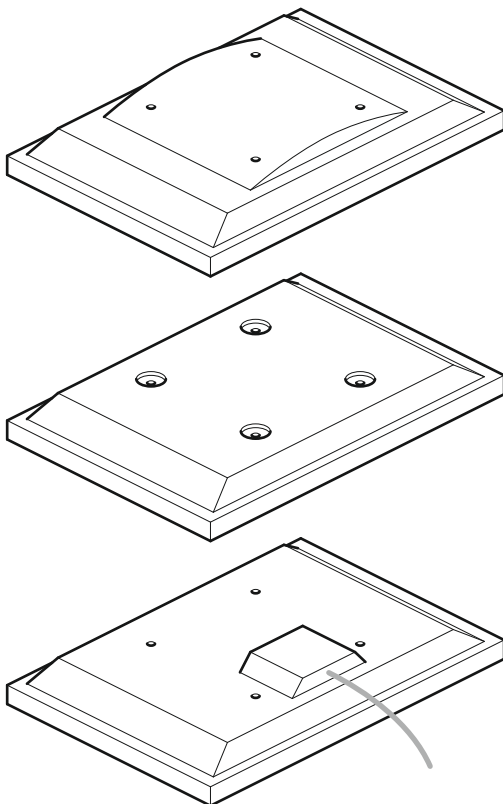
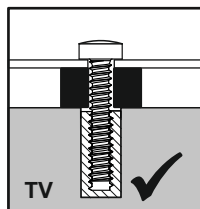
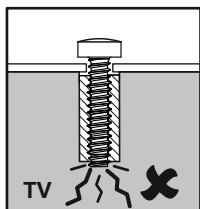
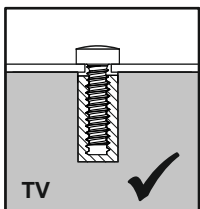
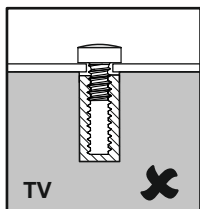
**WARNING / ADVERTENCIA**

After completing step 3 you will have fittings left over, please keep for future reference.

Después de completar el paso 3 usted tendrá conexiones sobrantes, por favor guarde para futura referencia.



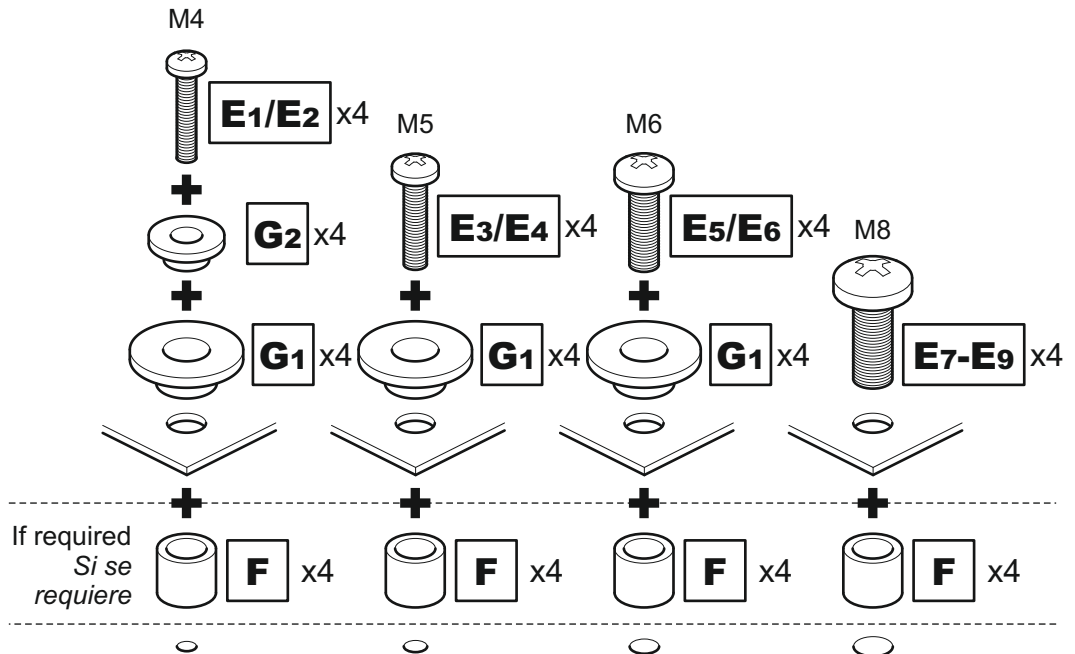
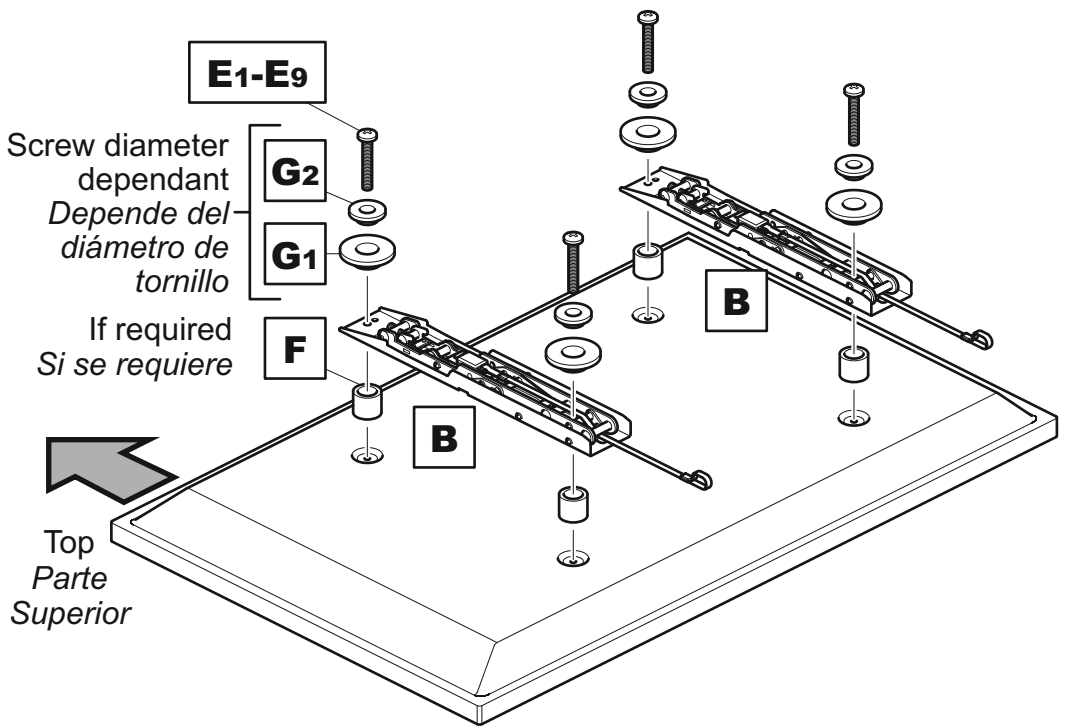

Attach the bracket to the back of your TV using suitable screw, reducer and spacer combinations.
Coloque los soportes a la parte posterior de su TV usando la combinación adecuada de tornillo, reductor y espaciador.

4 Fitting the Wall Bracket
Fije la Placa a la Pared

Solid Wall
Pared sólida

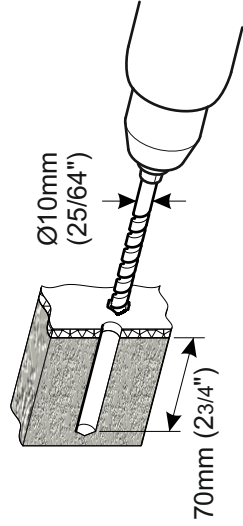
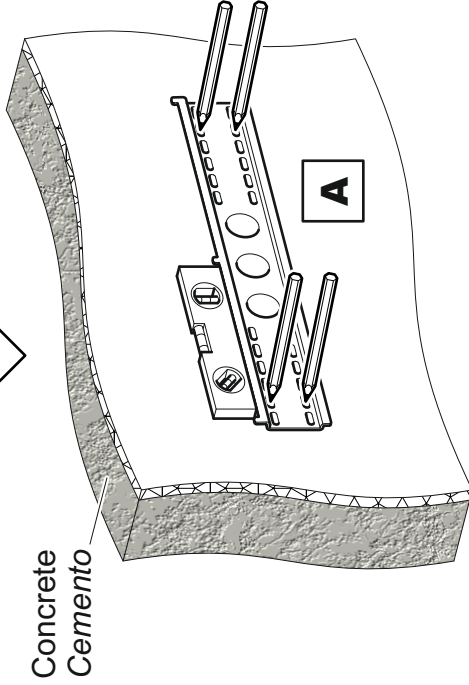

Remove dust from hole
Elimine el polvo del agujero



Wood Stud
Estructura de madera

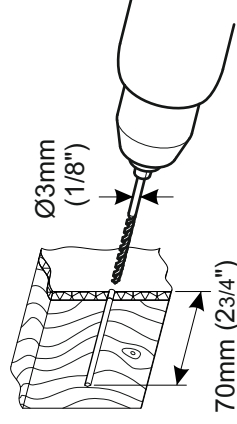
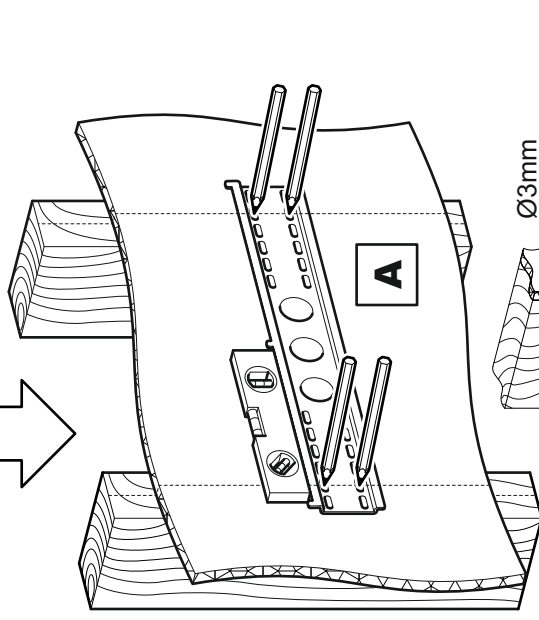

Ensure bracket is in the centre of the
wood stud

*Asegúrese de que el soporte está en el
centro de la viga de madera*



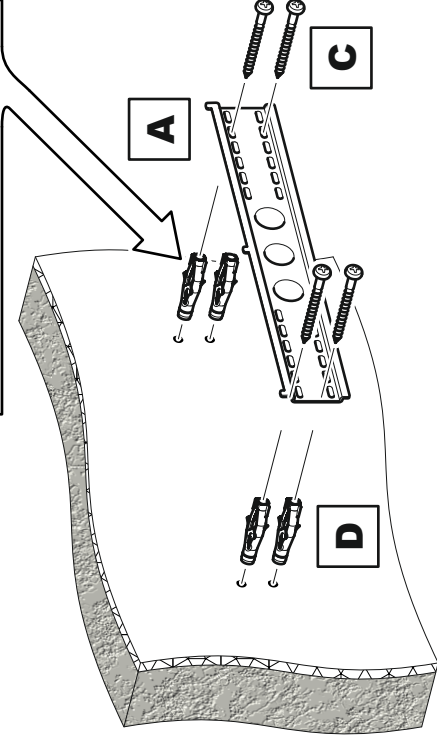
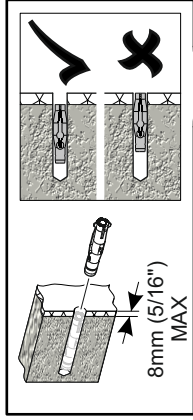
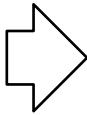

Lubricate screw thread
Lubrique la rosca del tornillo con jabón



DO NOT over tighten screws.
Tighten screws by hand only.
NO sobre apriete los tornillos.
Apriete los tornillos sólo a mano.



C x4

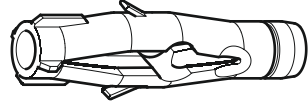

D x4

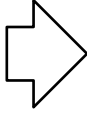

Lubricate screw thread with soap
Lubrique la rosca del tornillo con jabón

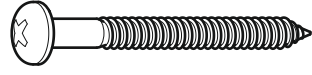
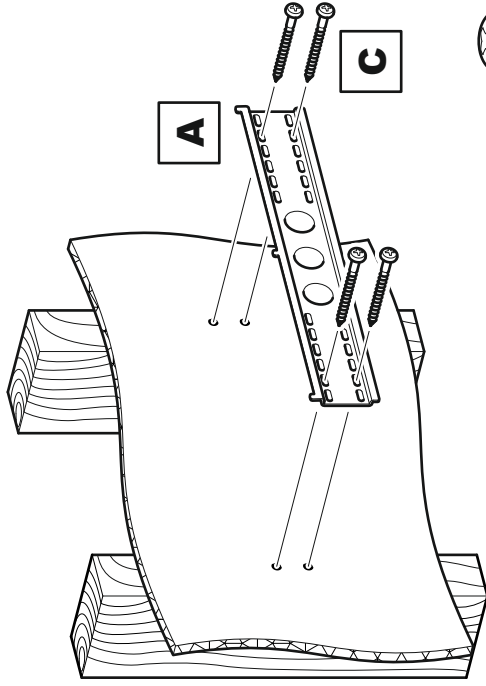

C x4

DO NOT over tighten screws.
Tighten screws by hand only.
NO sobre apriete los tornillos.
Apriete los tornillos sólo a mano.



5

Connect the TV Conecte la TV

Attaching
Colocación

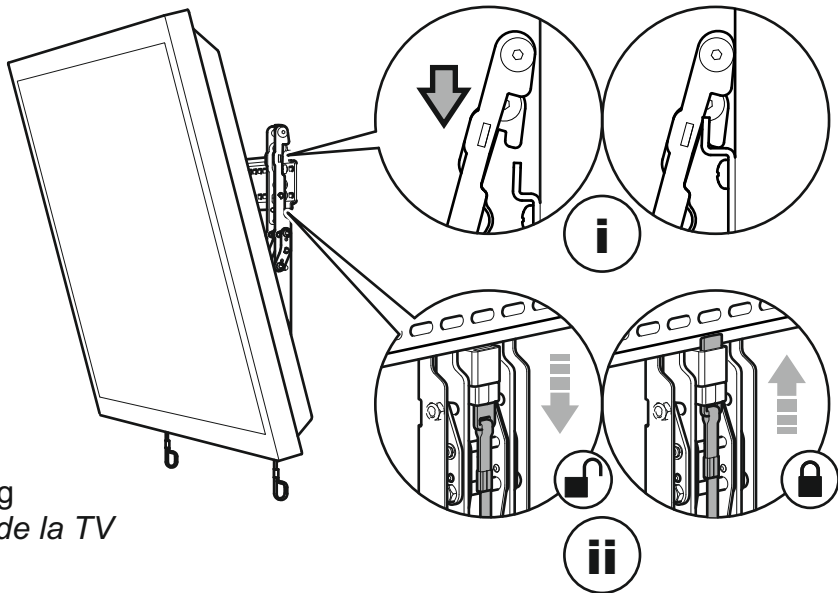

TV Levelling
Nivelación de la TV

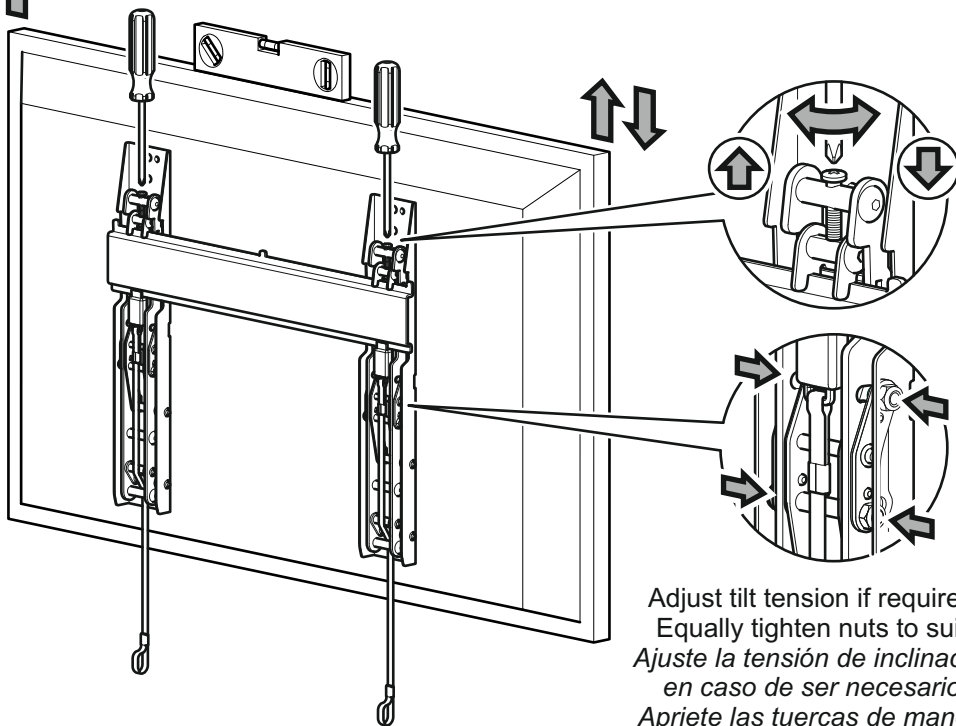

Adjust tilt tension if required.
Equally tighten nuts to suit.
*Ajuste la tensión de inclinación
en caso de ser necesario.
Apriete las tuercas de manera
simétrica para fijar el sistema*