

NZL2500

Leaflet No. 464054 rev01

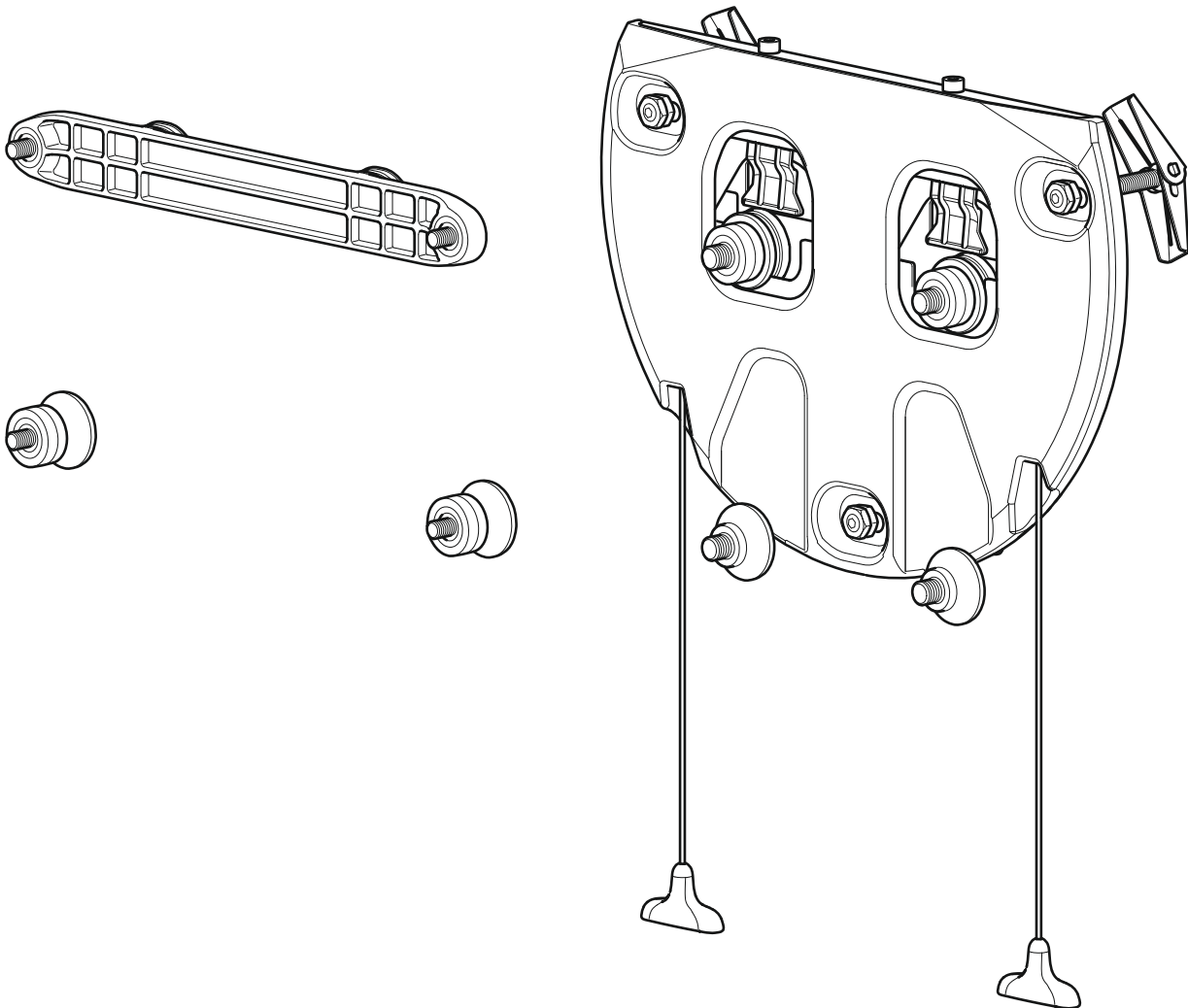

Read through ALL instructions before commencing installation. If you have any questions about this product or issues with installation contact the customer services help line before returning this product to the store. Visit <http://te.avf.co.uk/p/nzl2500> for more information.

CUSTOMER SERVICES HELP LINE NUMBER:

01952 670009



1 Boxed Parts

You will not need all these parts, so expect there to be some left over depending upon the specification of your TV.

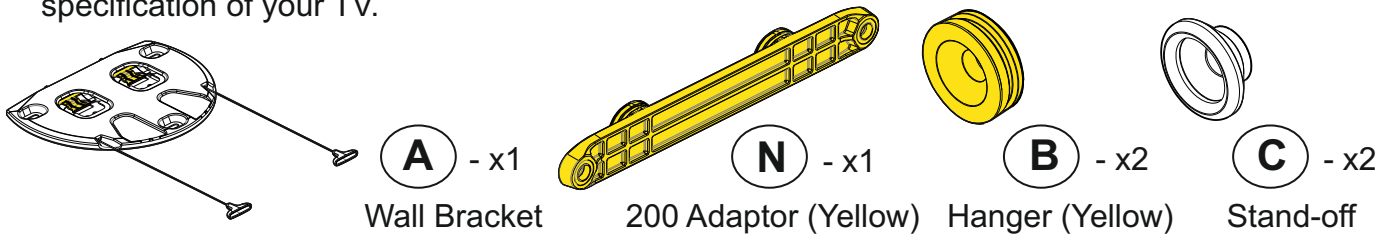

TV Fixings: Parts go on the back of the TV (specification of your TV will determine which ones you require - see section 9).

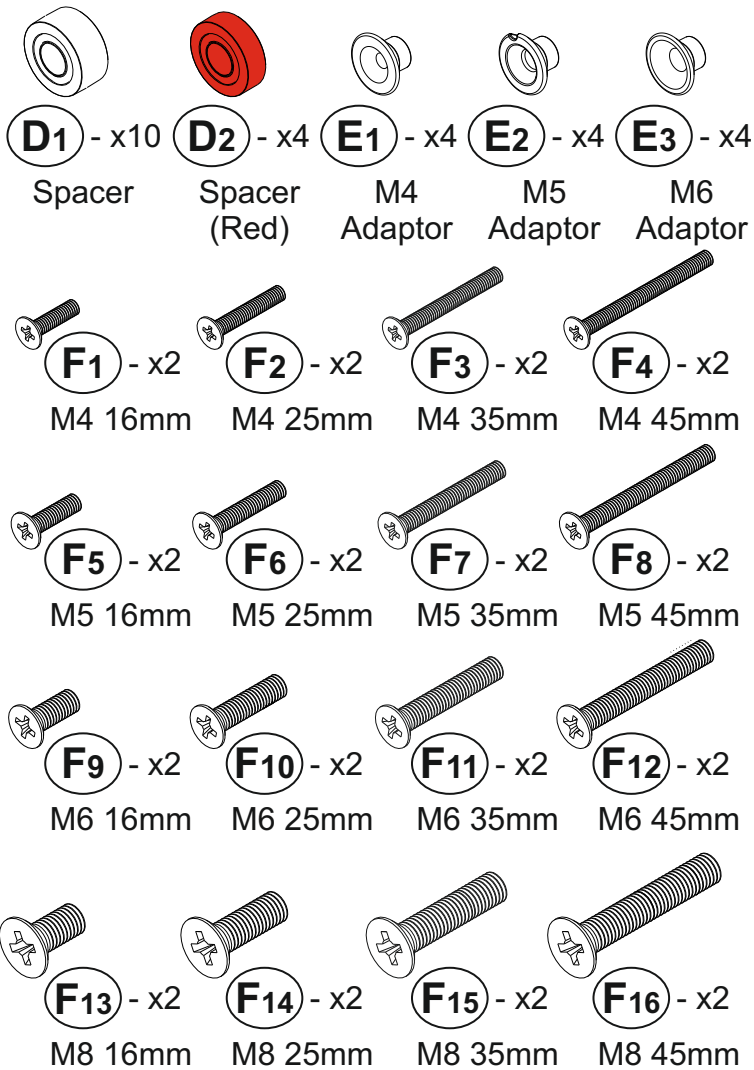

Wall Fixings: Parts to attach to the wall (type of wall will determine which fixings you require).

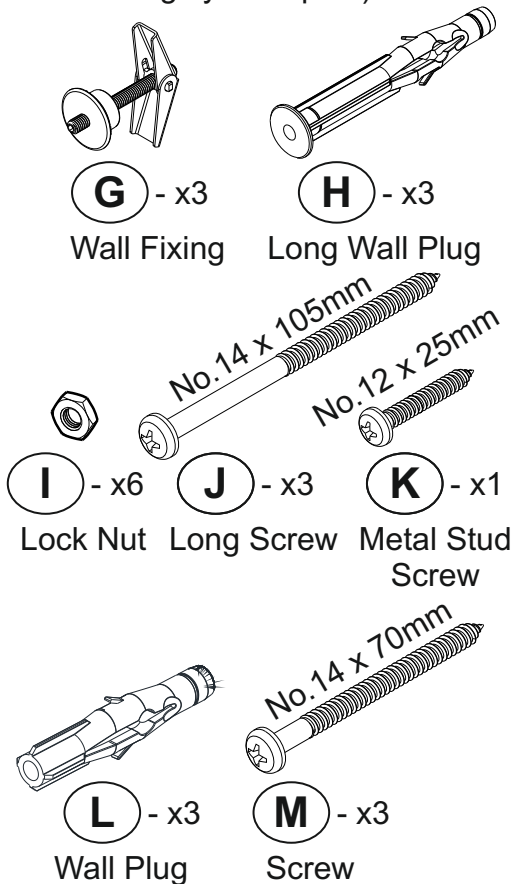

Included Tools

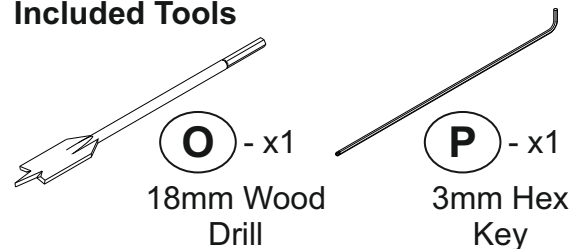

2 Tools Recommended

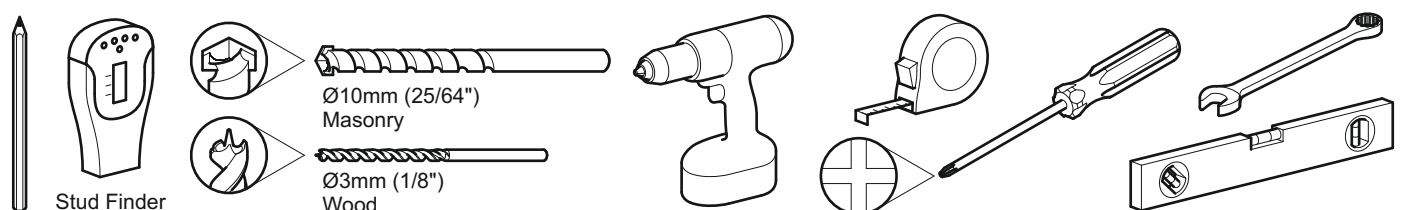

3 Determine Correct TV Screw Size

Choose from the TV Fixings selection. You need to determine which diameter of screw fits your TV. To determine the correct screw diameter, try screwing (F₂), (F₆), (F₁₀) & (F₁₄) into one of the fixing holes on the back of the screen until you find the one that fits. Note the thread size and ensure to use the appropriate diameter screws.

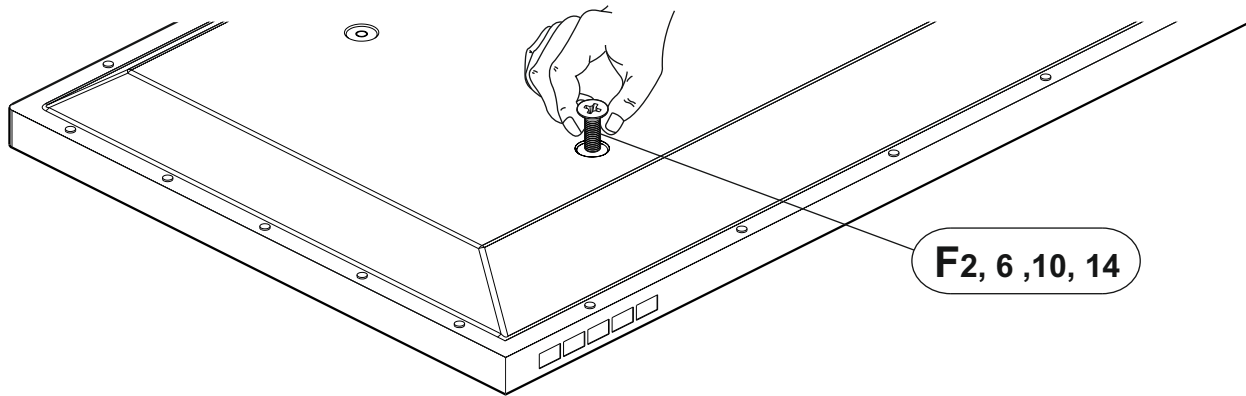

4 Fit Screen Hangers To TV

Once you have established which screws you need for your TV you can attach the Hangers (B) or 200 Adaptor (N) and Stand-offs (C) to the back of your TV.

Typical recommended examples shown are for fixings with the TV spaced 20mm from the wall. The TV Mount can position your TV between 12mm and 40mm from the wall. For alternative configurations see sections 9.

You might need to use spacers to increase the clearance of your TV from the wall in order to avoid cables coming out of your TV and improve access and ventilation to the back of your TV (spacers (D) allow you to have a gap of 20mm, 30mm or 40mm, see sections 9).

In certain circumstances it may be necessary to use red spacer (D₂) as either a replacement or addition to spacer (D₁), for more information please see section 9.

Measure your TV fixings centres to determine whether to use option 1 or option 2. If your TV fixing centres don't suit either option, STOP installation and contact the customer services helpline.

Option 1

VESA Standard 75x75 & 100x100

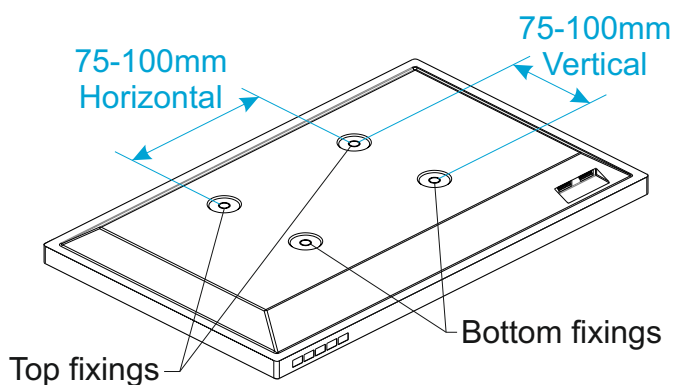

Option 2

VESA Standard 200x100 & 200x200

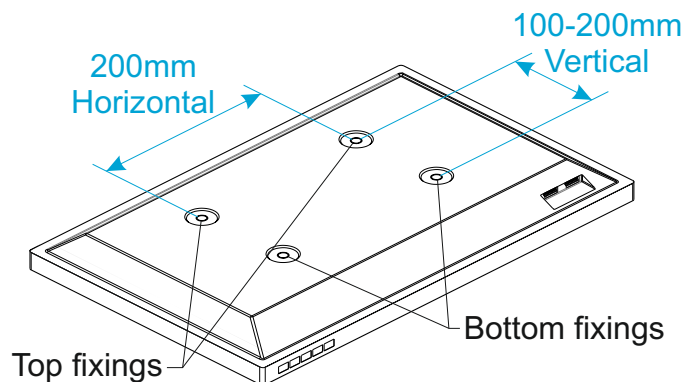

Option 1 continued

Option 2 continued

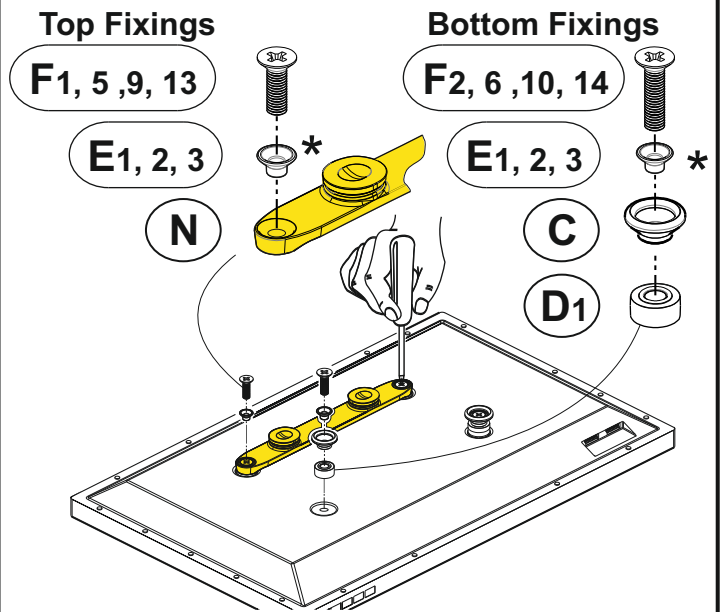
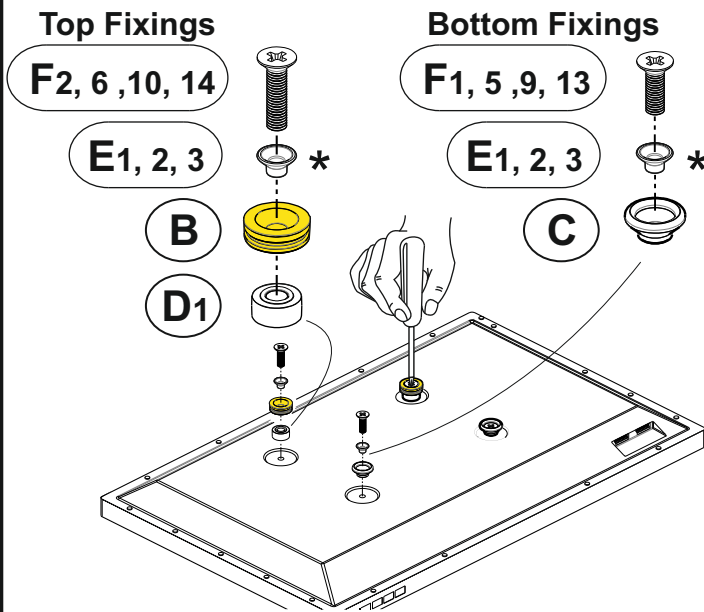

TV must be parallel to wall. Use spacers / stand-offs as shown.

- If using screws (F1) & (F2) use Adapter (E1)
- * If using screws (F5) & (F6) use Adapter (E2)
- If using screws (F9) & (F10) use Adapter (E3)
- If using screws (F13) & (F14) no Adapter required

5 Marking Wall For Drill Points

Use the Wall Bracket (A) as a template and position it on your wall. Ensure the bracket is level and mark the three DRILL POINTS with a pencil.

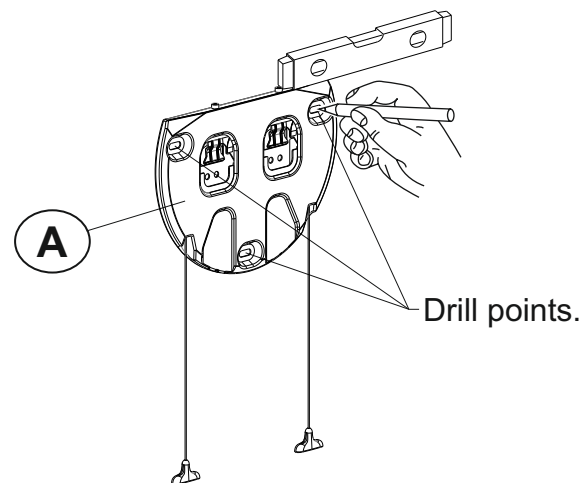

6 Planning & Preparation

Determine the wall type that you have (i.e. Solid Wall / Dot & Dab / Plasterboard/Sheetrock / Wood Stud / Metal Stud) and select the appropriate fixings (See Section 7). Ensure the drilling area is free from mains services (Gas / Electric / Water).

7 Install Wall Fixings

Use the correct fixings for your wall type. Mixing fixing types may be required for installations that span different wall types. **DO NOT OVER TIGHTEN SCREWS.**



Solid Wall

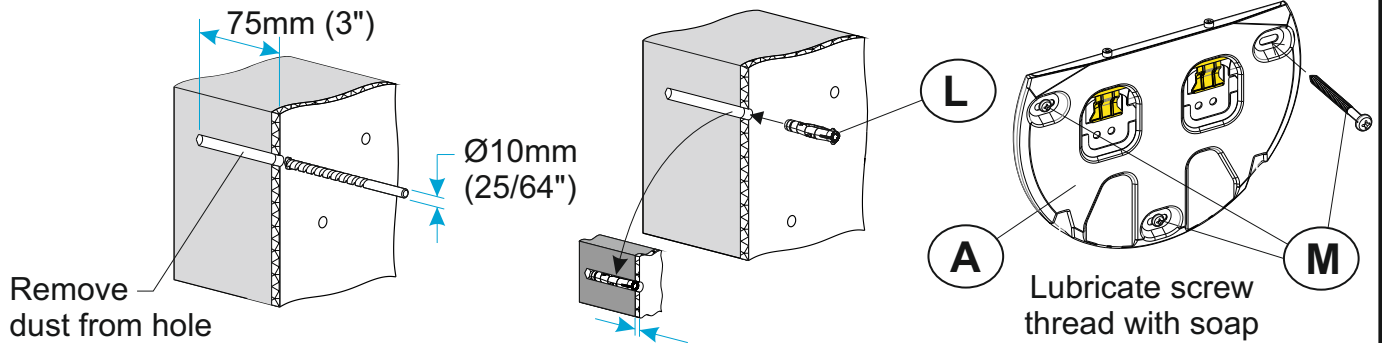

Dot & Dab

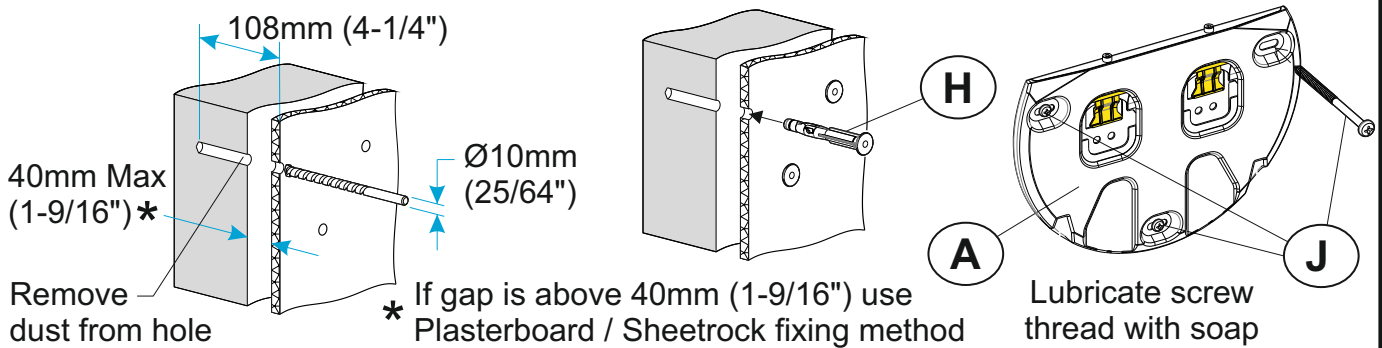

Plasterboard / Sheetrock

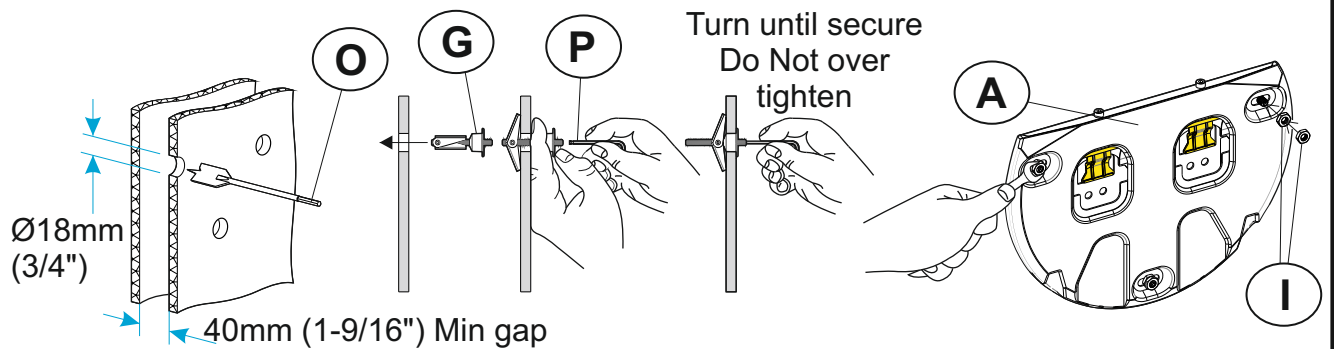

Wood Stud

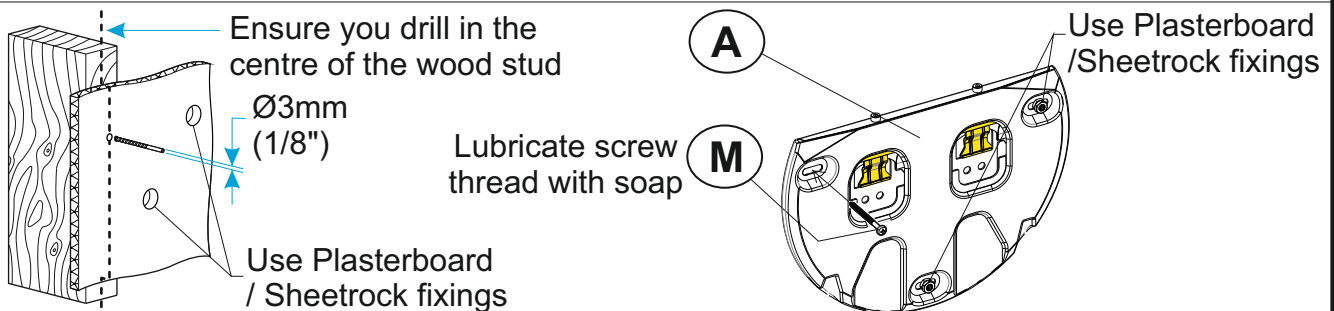

Only one fixing will be in the wood stud. The other fixings will be in plasterboard / sheetrock (see above).

Metal Stud

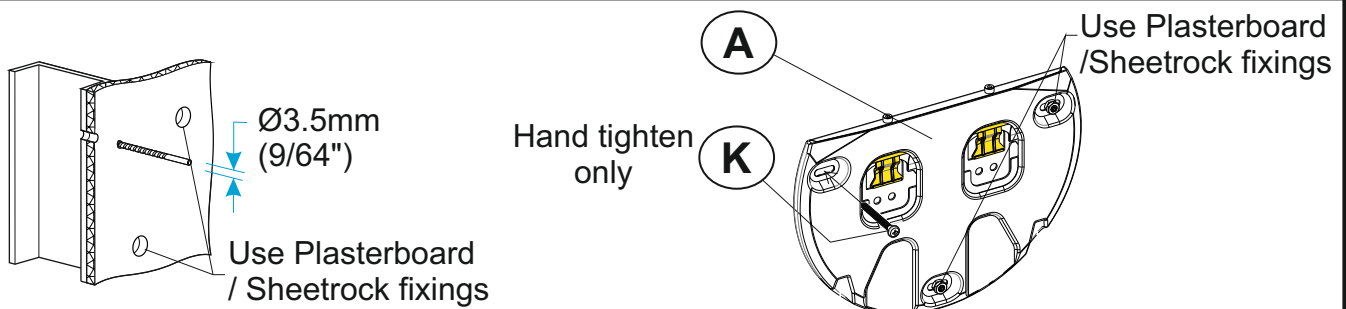

Only one fixing will be in the metal stud. The other fixings will be in plasterboard / sheetrock (see above).

8 Hanging The TV

TV must be parallel to wall. Use spacers / stand-offs as shown.

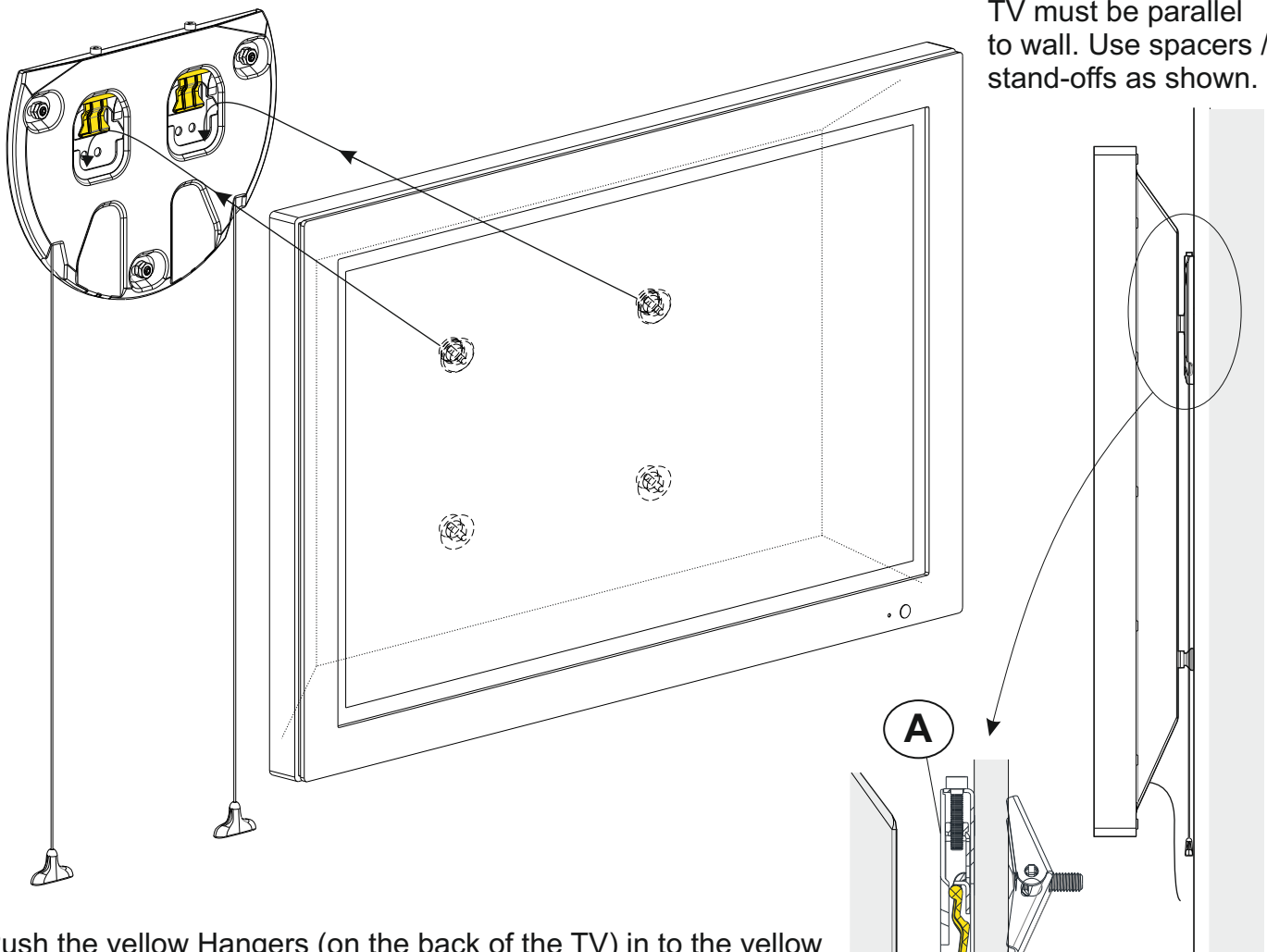

Push the yellow Hangers (on the back of the TV) in to the yellow receptor on the Wall Brackets. Slide down into place. Ensure both yellow Hangers are fully engaged. If cables from the TV prevent the TV resting against the wall then an alternative fixing configuration will be required (See Section 9).

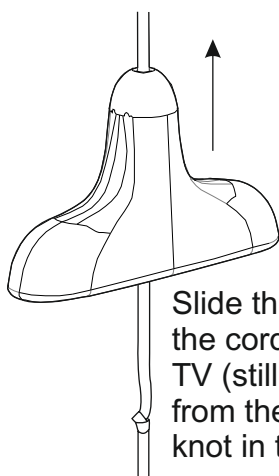

Slide the pull cord handles up the cord so they are behind the TV (still accessible but not visible from the front of the TV). Tie a knot in the cord and cut off the excess.

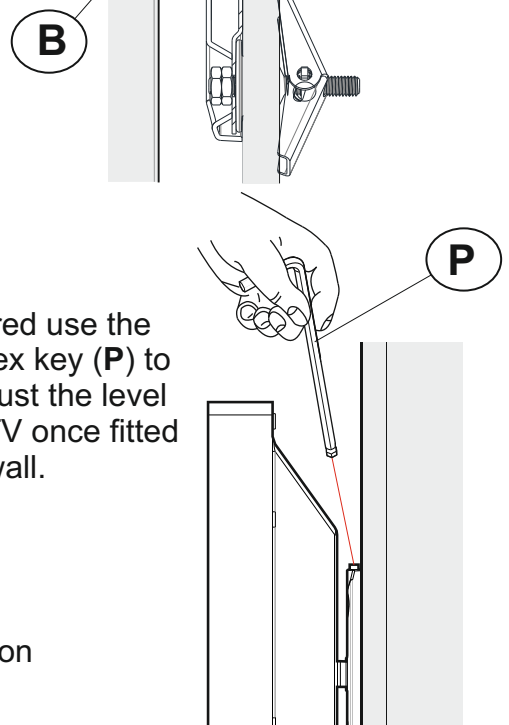

If required use the 3mm hex key (P) to fine adjust the level of the TV once fitted to the wall.

Removing the TV:-

This is a two person job. To remove the TV, one person should pull both Pull Cords while another lifts the TV.

9

Alternative Hanger Configurations

Alternative Wall spacings of 12mm, 20mm, 30mm & 40mm can be achieved using the spacer / screw combinations listed in this section.

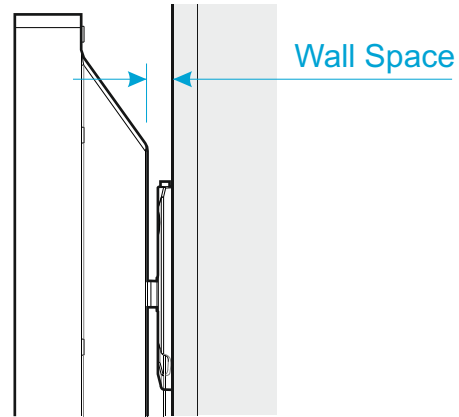

Option 1

VESA Standard 75x75 & 100x100

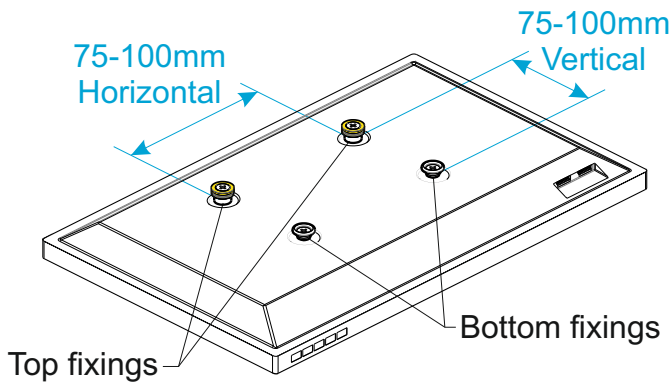

Option 2

VESA Standard 200x100 & 200x200

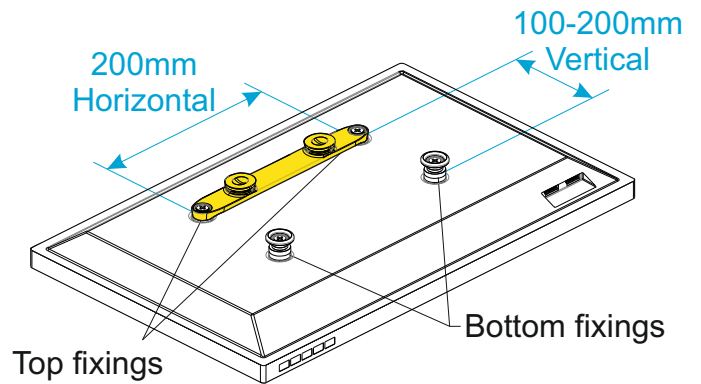

Top Fixings

Bottom Fixings

----- 12mm Wall Space -----

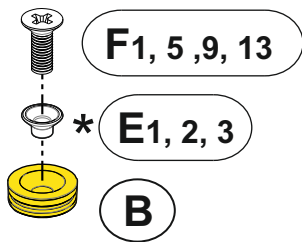

No screws or Stand-offs on bottom

Top Fixings

Bottom Fixings

----- 12mm Wall Space -----

No 12mm configuration available for this option

----- 20mm Wall Space -----
(as shown in section 4)

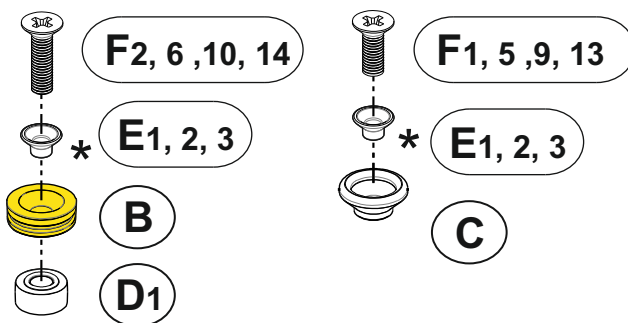

----- 20mm Wall Space -----
(as shown in section 4)

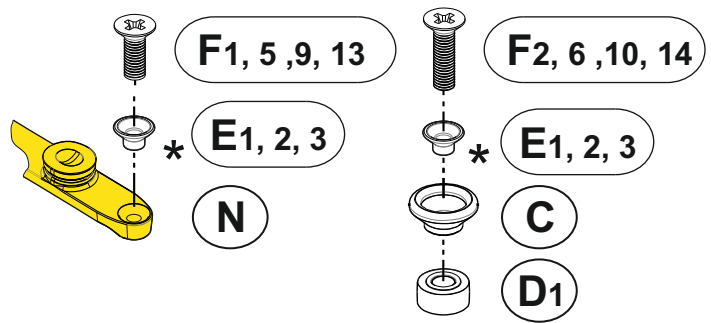

Option 1 continued

Top Fixings

Bottom Fixings

----- 30mm Wall Space -----

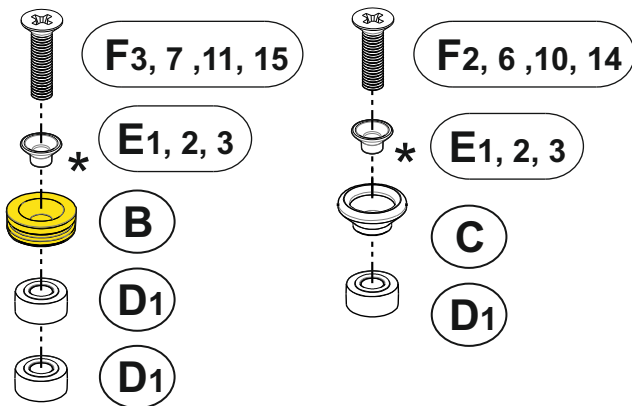

----- 40mm Wall Space -----

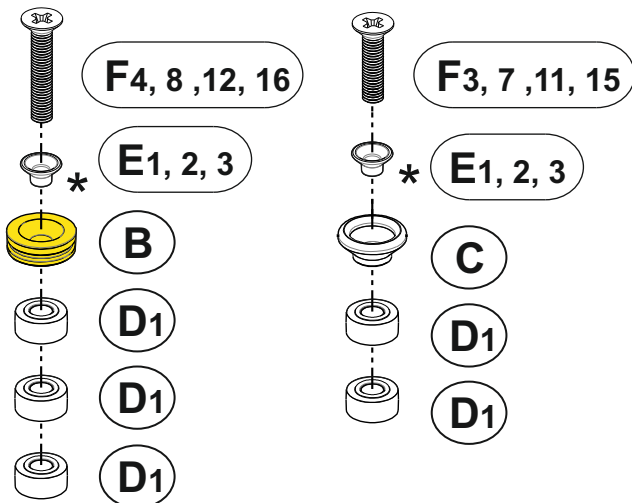

Option 2 continued

Top Fixings

Bottom Fixings

----- 30mm Wall Space -----

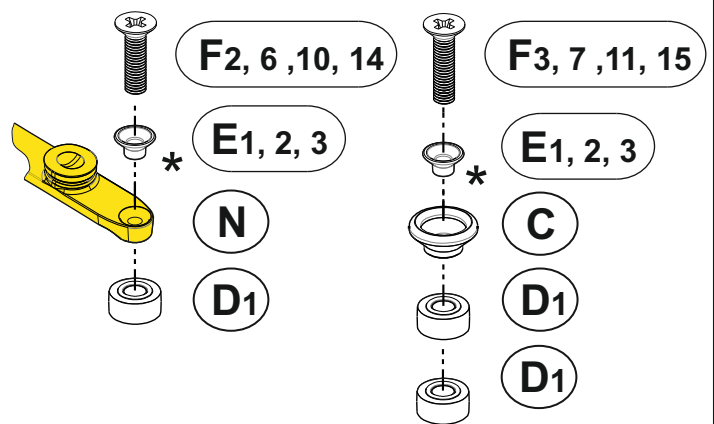

----- 40mm Wall Space -----

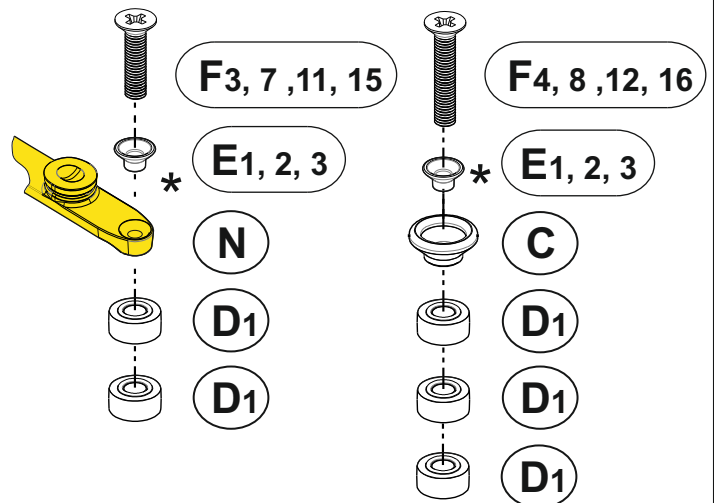

TV must be parallel to wall. Use spacers / stand-offs as shown.

- Use adapter (E₁) with screws (F₁), (F₂), (F₃) & (F₄)
- Use adapter (E₂) with screws (F₅), (F₆), (F₇) & (F₈)
- * Use adapter (E₃) with screws (F₉), (F₁₀), (F₁₁) & (F₁₂)
- No adapter required with screws (F₁₃), (F₁₄), (F₁₅) & (F₁₆)

When is it necessary to use red spacers?  (D₂) - x4

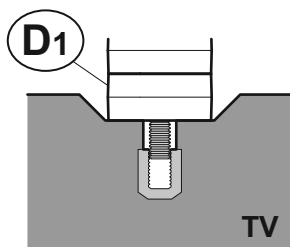

Problem
Not enough
screw engagement

It is recommended that when fitting Hanger (B) or Adaptor (N) and Stand-offs (C) to your TV you have at least 5-10mm of screw engagement. In certain circumstances you may need to use red spacers (D₂) as either a replacement, or together with spacers (D₁) to achieve this. Whenever you use red spacers (D₂) you must use all 4 provided.

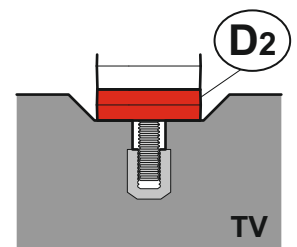

Solution
Red spacer (D₂) has
replaced spacer (D₁)