

# JZL6701

Leaflet No. **464013** rev01

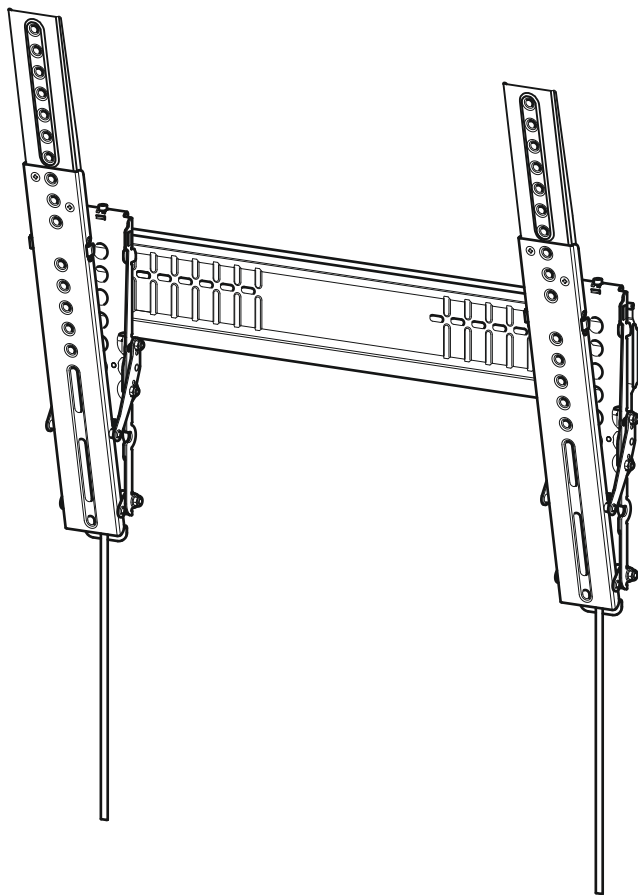

*Read through **ALL** instructions before commencing installation. If you have any questions about this product or issues with installation contact the customer services helpline before returning this product to the store. See [jl.avfgroup.com/p/jzl6701](http://jl.avfgroup.com/p/jzl6701) for more information.*

CUSTOMER SERVICES HELP LINE NUMBER:

**01952 670009**



**AVF Group Ltd.** Hortonwood 30, Telford, Shropshire, TF1 7YE, England

# Assembly Overview

## Fit the TV Brackets

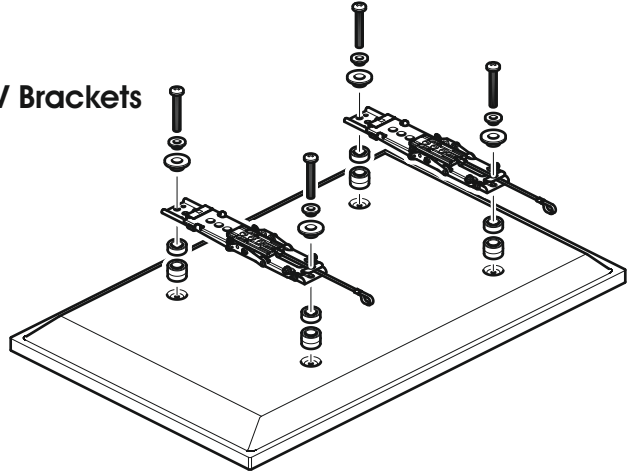

## Fit the Wall Bracket

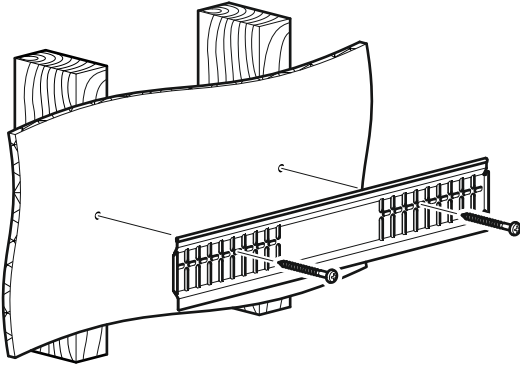

## Connect the TV

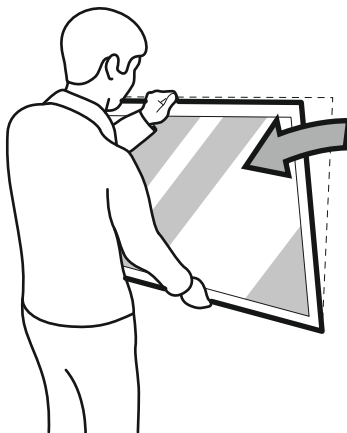
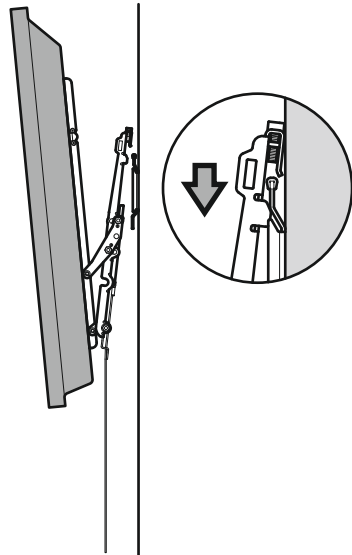

Tilt (if required)

## Index

**1** Measure the TV fixing holes Width and Height

**2** Preparing the TV Brackets

**3** Fitting the TV Brackets

**4** Fitting the Wall Bracket

**5** Connecting the TV

Retain all packaging in case the bracket needs to be returned.

Contents may vary from photography/ Illustrations.

You will not need all these parts, so expect there to be some left over depending upon the specification of your TV.

This product is intended for indoor use only. Use of this product outdoors could lead to failure and personal injury.

It is the responsibility of the installer to ensure that the mounting wall is of a suitable standard and void of any services (eg gas, electricity, water etc).

AVF accept no responsibility for any damage or loss caused by installing this product in a sub standard wall.

## Tools Recommended

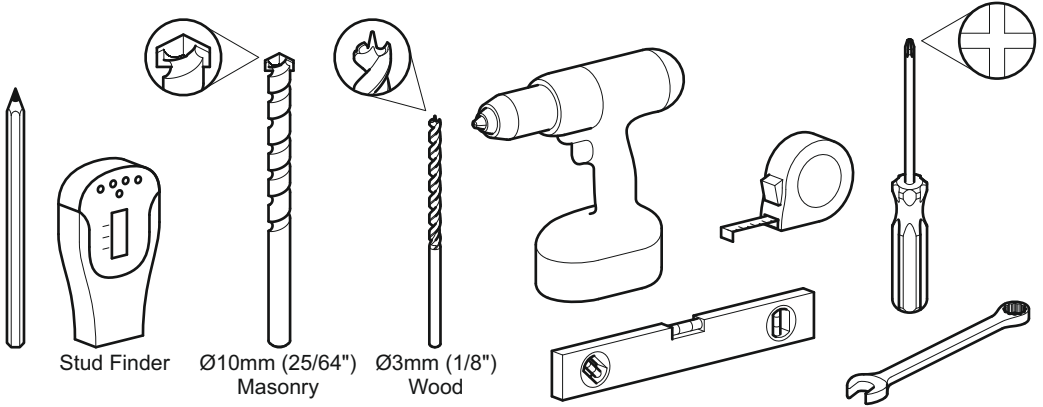

## Boxed Parts

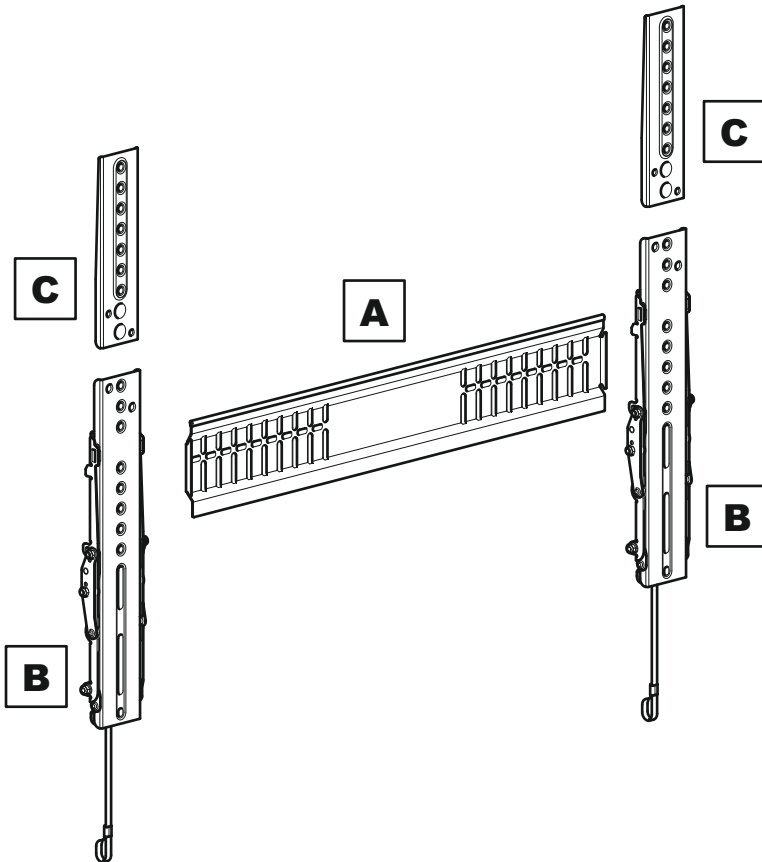

# TV Screws, Reducers and Spacers

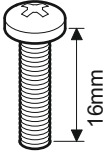

M4  
**D1** x4

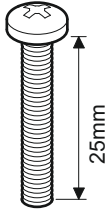

M4  
**D2** x4

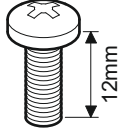

M5  
**D3** x4

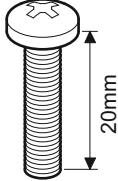

M5  
**D4** x4

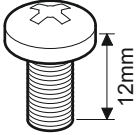

M6  
**D5** x4

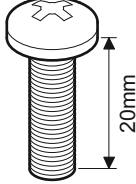

M6  
**D6** x4

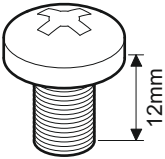

M8  
**D7** x4

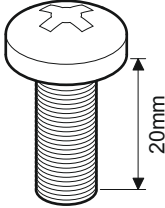

M8  
**D8** x4

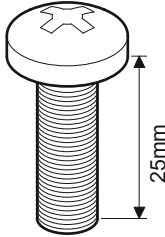

M8  
**D9** x4



**E1** x4



**E2** x4



**F1** x4



**F2** x4

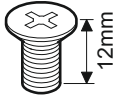

M5  
**G** x4



**H** x4



**I** x4

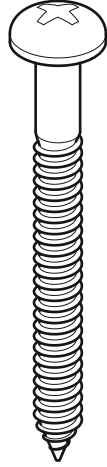

**J** x4

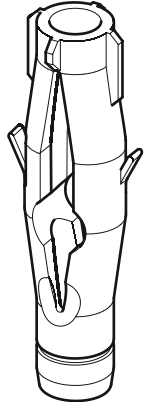

**K** x4

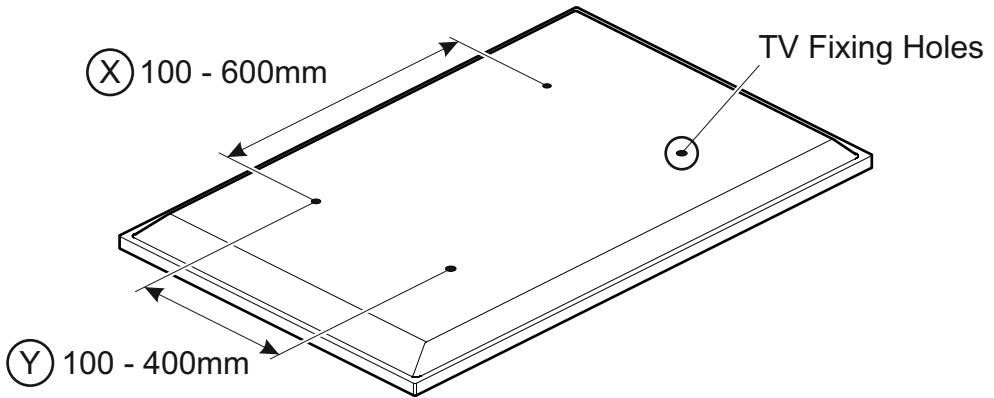

**L** x1

**1****Measure the TV fixing holes Width and Height**

If width (X) is greater than 600mm or height (Y) greater than 400mm  
STOP installation now and contact the customer help line

You are provided with 4 diameters of TV fixing screws, **M4**, **M5**, **M6** and **M8**. Determine the screw diameter that fits and remember for step 3.

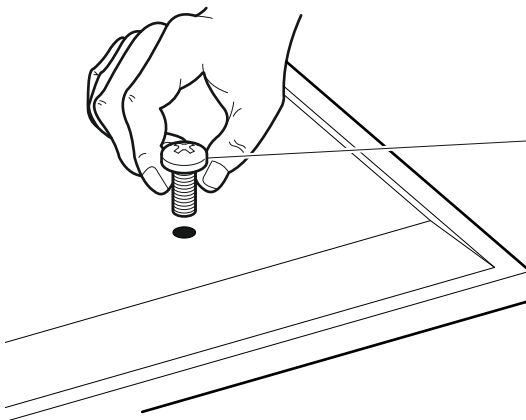

<b>M4</b> =	<b>D1/D2</b>
<b>M5</b> =	<b>D3/D4</b>
<b>M6</b> =	<b>D5/D6</b>
<b>M8</b> =	<b>D7-D9</b>

## 2

### Preparing the TV Brackets

To ensure maximum tilt is possible after installation you will need to ensure that your TV does not clash with the wall.

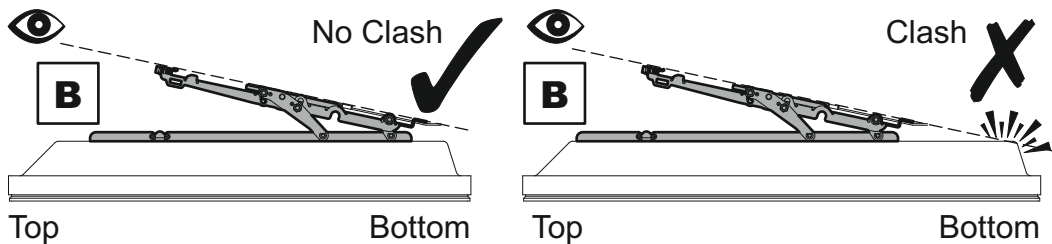

If a clash is observed you will need to use adaptors **C** to position the TV Brackets **B** closer to the bottom of the TV to achieve maximum tilt.

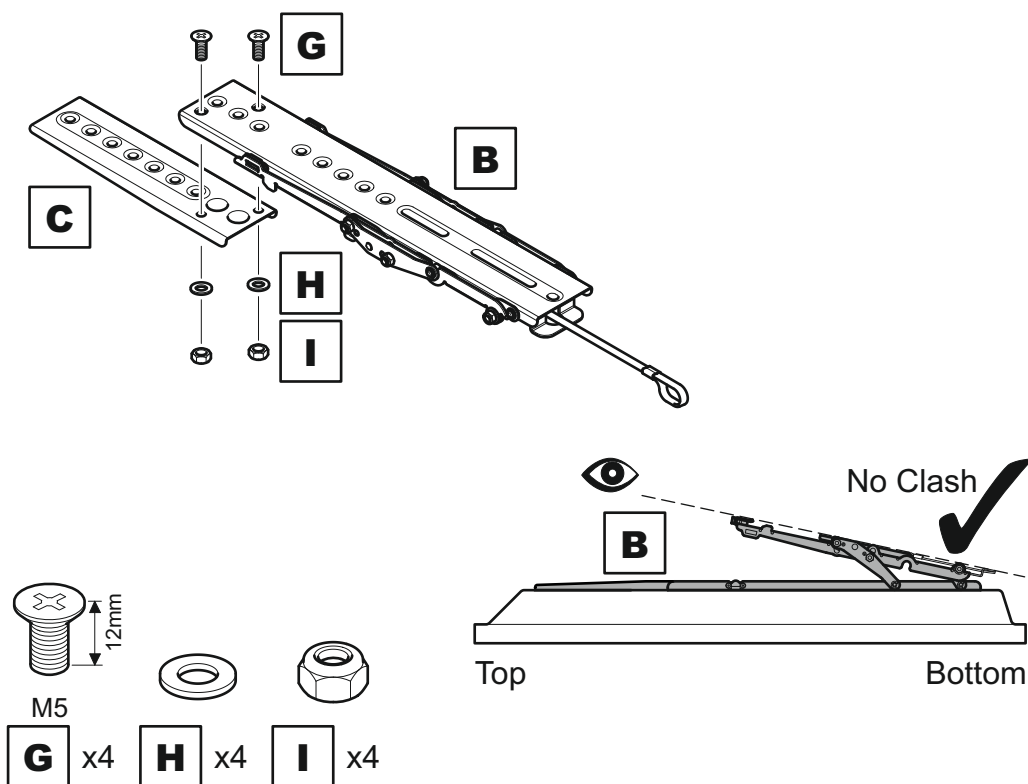

### 3 Fitting the TV Brackets

#### No Spacers

For Tvs with flat/unobstructed back

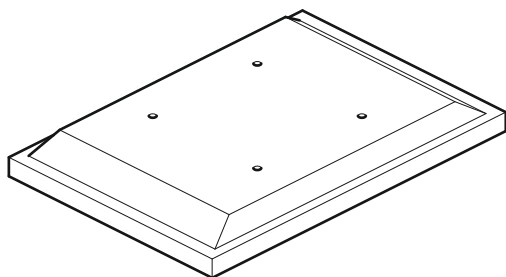

#### Spacer **F1/F2**

For Tvs with irregular/obstructed back

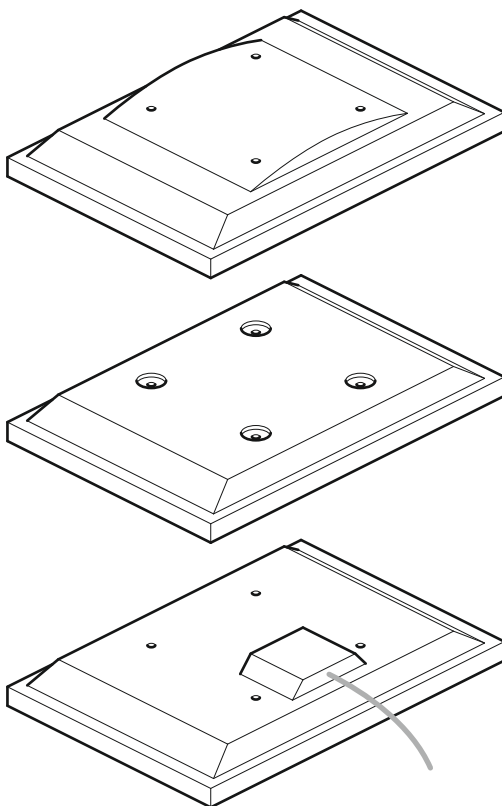

#### WARNING

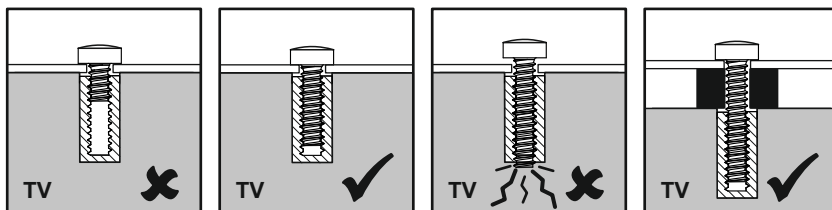

After completing step 3 you will have fittings left over, please keep for future reference



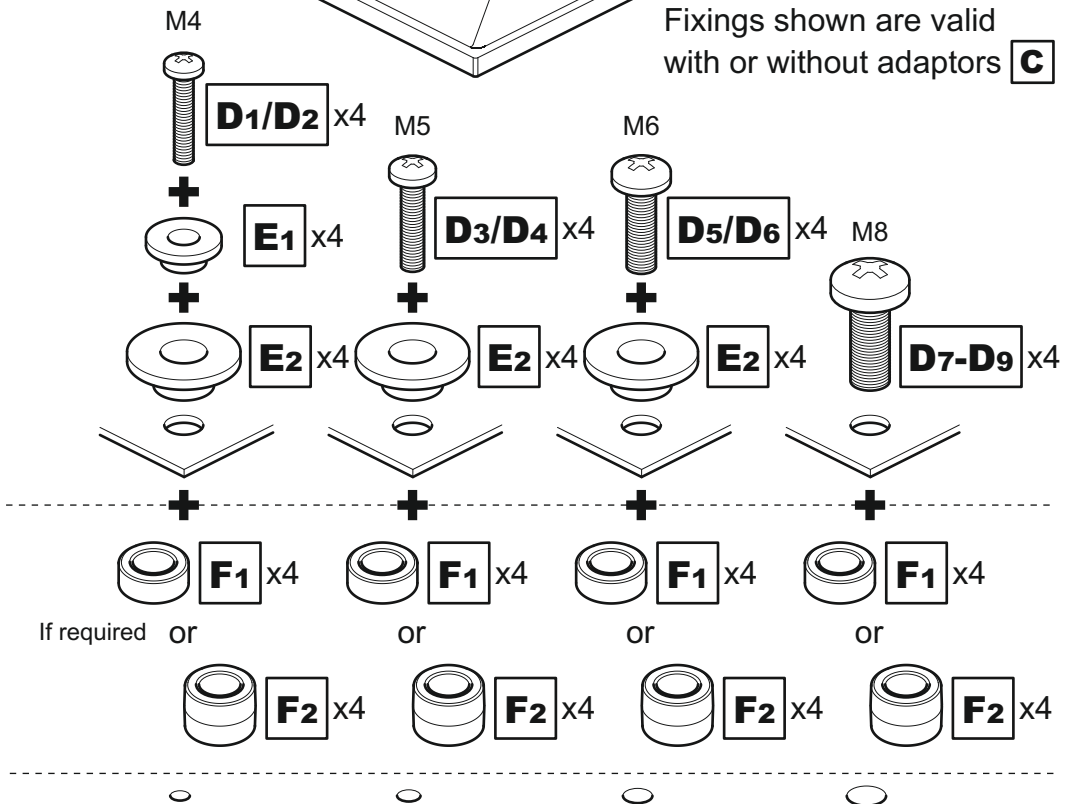
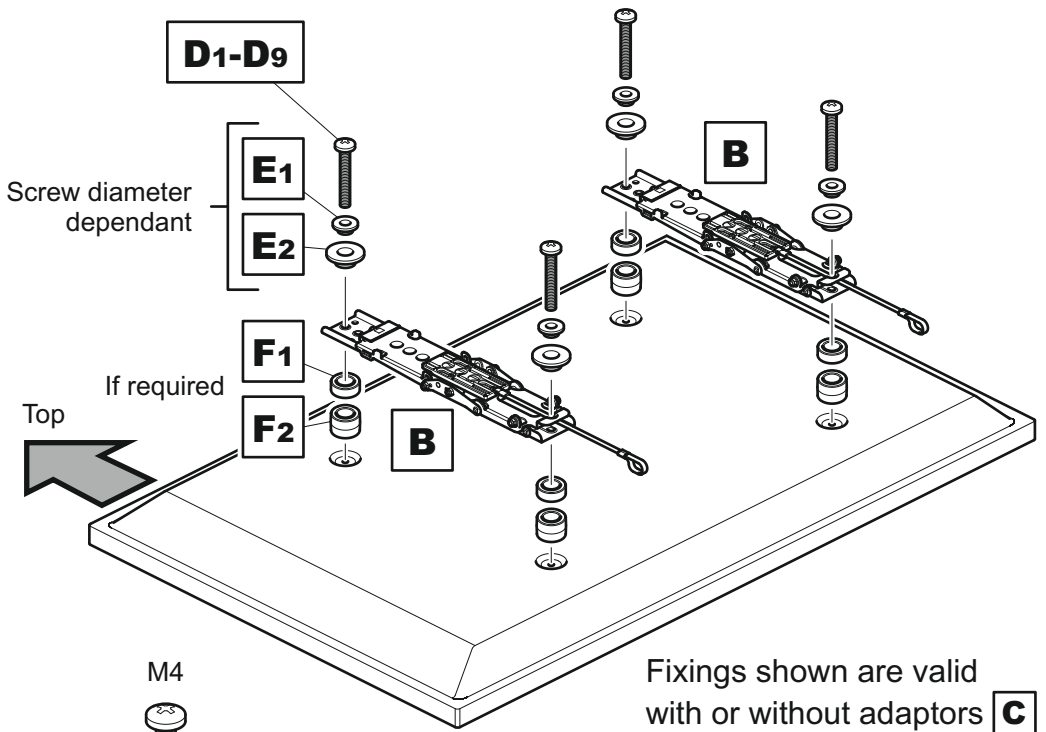

Attach the bracket to the back of your TV using suitable screw, reducer and spacer combinations.

# 4 Fitting the Wall Bracket

Solid Wall

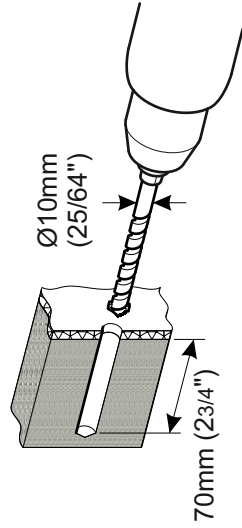
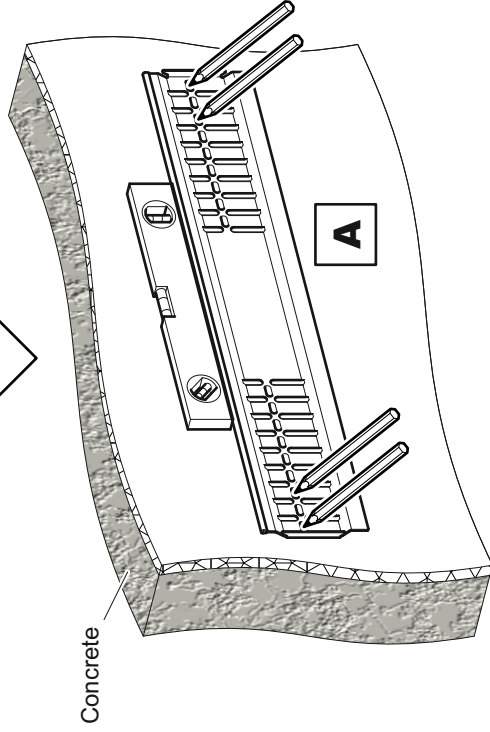

Remove dust from hole



Wood Stud

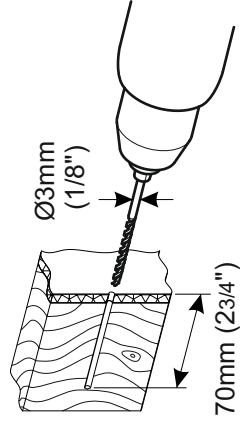
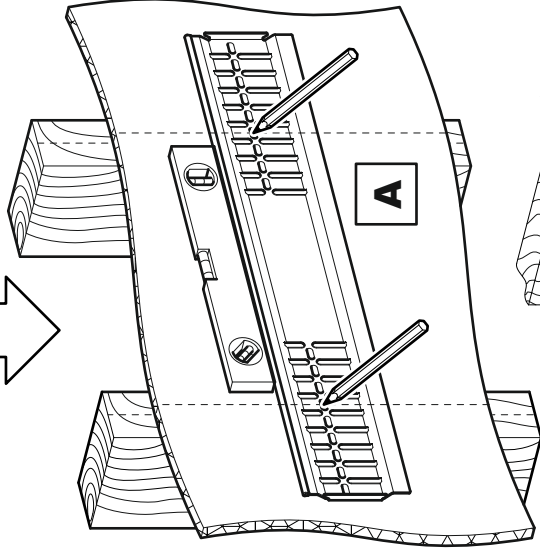

Ensure bracket is in the centre of the wood stud



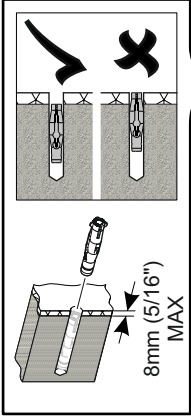
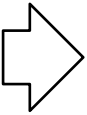

8mm (5/16")  
MAX

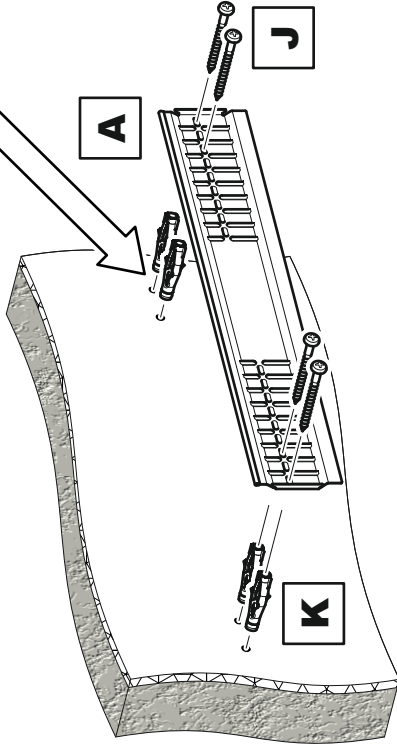

Lubricate screw  
thread with soap



DO NOT over tighten screws  
Tighten screws by hand only



x4



x4

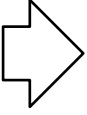

Lubricate screw  
thread with soap

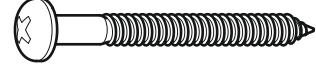
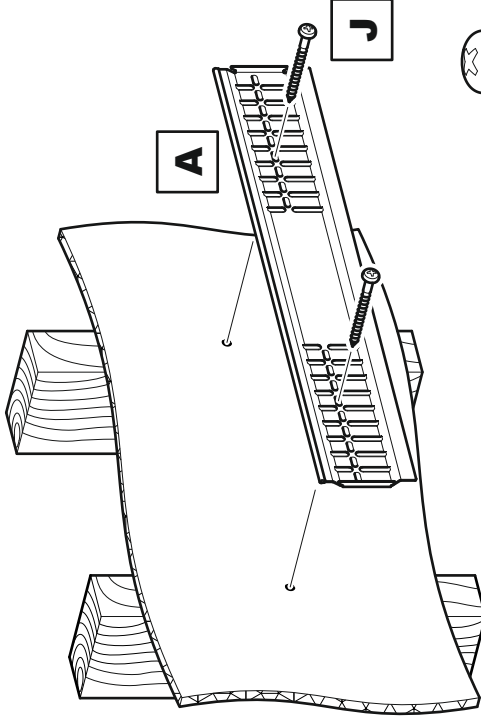

x4



DO NOT over tighten screws  
Tighten screws by hand only



x4

# 5

## Connecting the TV

### Attaching

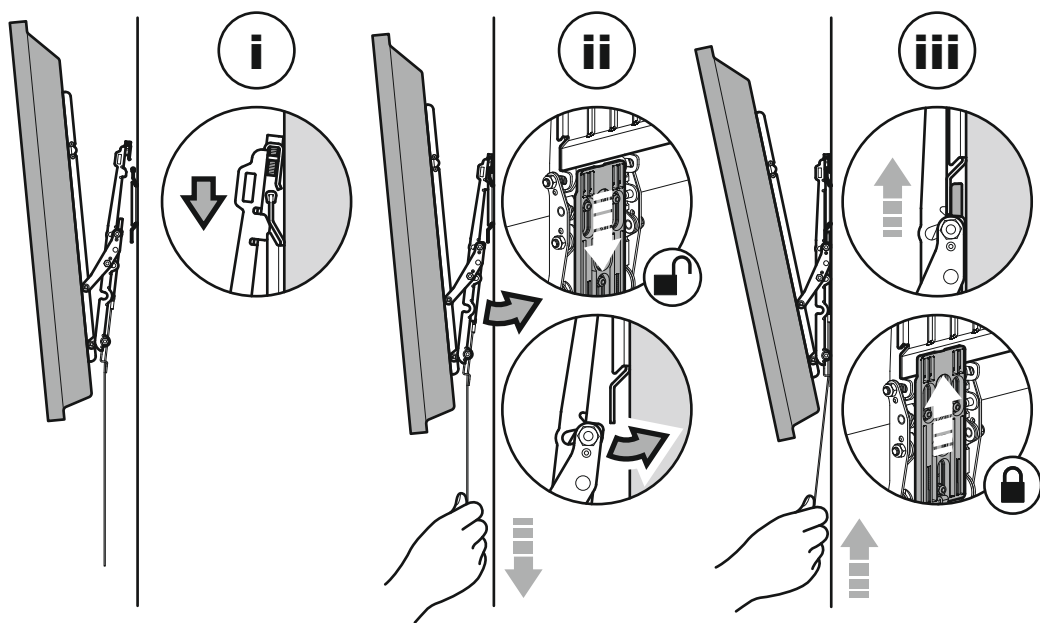

### TV Levelling

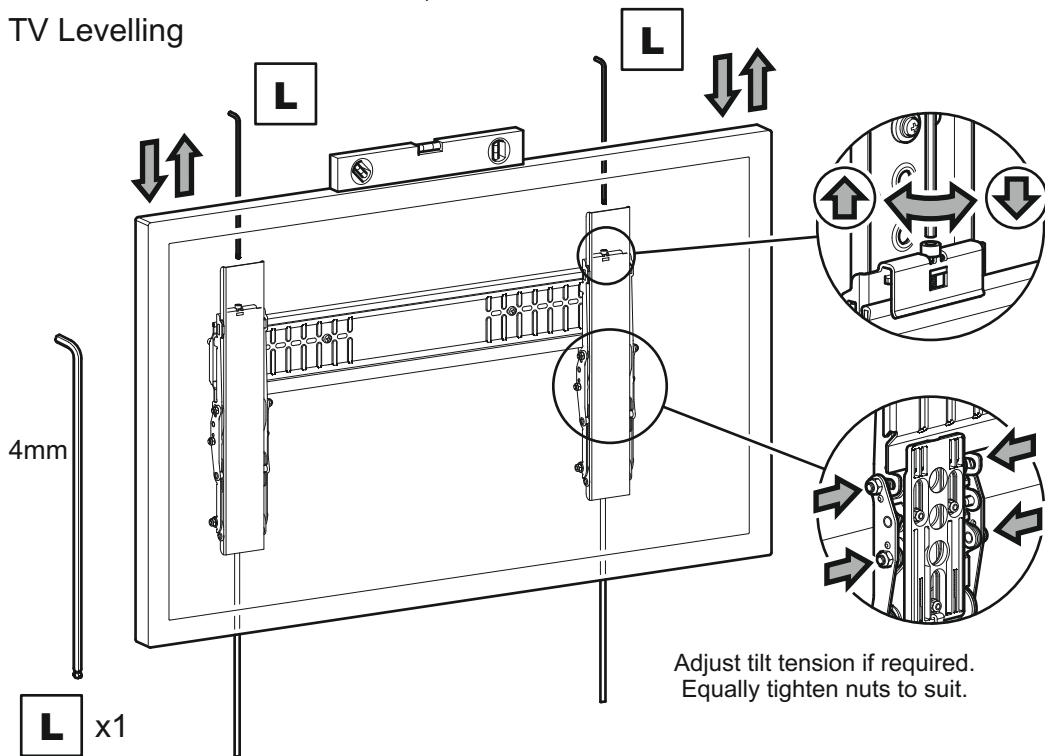

Adjust tilt tension if required.  
Equally tighten nuts to suit.