

**Read through ALL instructions before commencing installation.**  
**If you have any questions about this product or issues with installation contact the customer services help line before returning this product to the store.**



**Lisez toutes les instructions avant de débiter l'installation.**  
**Si vous avez des questions sur ce produit ou des problèmes d'installation, contactez l'assistance client avant de ramener le produit en magasin.**



**Lea todas las instrucciones antes de comenzar la instalación.**  
**Si tiene alguna pregunta sobre el producto o problemas con la instalación. llame a la línea de servicio al consumidor antes de devolverlo.**



This mount is intended for use with **55" Maximum** televisions and AV equipment with a combined weight of **Maximum 60kg (133lbs)**. Use with products heavier than maximum combined weight may result in instability causing possible injury.



Ce support est conçu pour des écrans jusqu'à 55" et des équipements AV avec un poids maximum combiné de 60 kg (133lbs). L'utilisation de ce support avec un poids cumulé supérieur au maximum recommandé peut résulter dans une instabilité du produit pouvant entraîner des risques de blessures.



Este soporte está diseñado para el uso con TVs hasta 55" y componentes Audio Visuales con un peso combinado máximo de 60 kg (133 libras). El uso con productos más pesados que el peso combinado máximo puede resultar en inestabilidad causando posibles lesiones..

#### AVF Group Ltd.

Road 30, Hortonwood Ind Est, Telford, Shropshire, TF1 7YE, England.

**+44 (0) 1952 670009 / 0870 0609777 (UK)**

#### AVF Incorporated.

3187, Cornerstone Drive, Mira Loma, CA 91752, USA.

**1-800 667 0808 (USA)**

#### Orbital Holdings Inc.

3187, Cornerstone Drive, Mira Loma, CA 91752, USA.

**1-800 601 8450 (USA)**



Combined 60kg (133lbs)  
60kg (133lbs) cumulé  
Combinado 60kg (133 lbs)



Shelf capacity 15kg (33lbs)  
L'étagère supporte 15kg (33lbs)  
Capacidad del estante 15 kg (33 lbs)

**Assembly Overview**  
*Vue d'ensemble de l'assemblage*  
**Ensambladura General**

**Assembling the Shelf Bracket**  
*Assemblage du support à étagère*  
**Ensamblando el Estante**

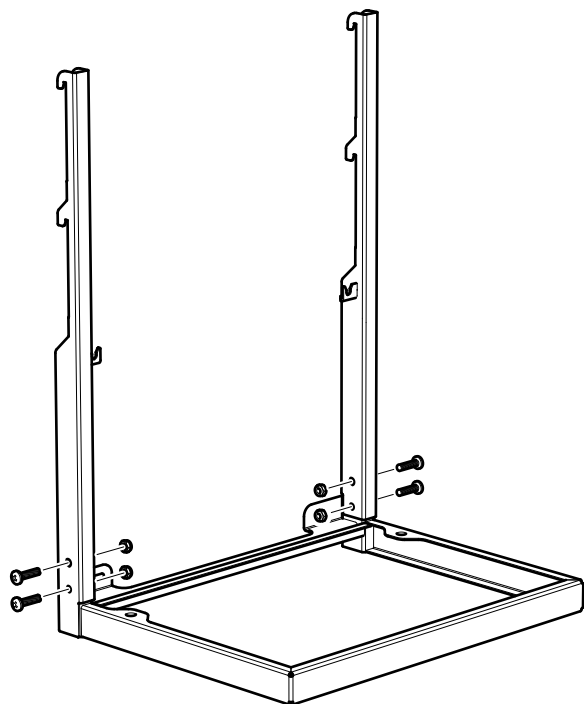

**Fitting the Wall Bracket**  
*Installer l'applique murale*  
**Fije la Placa a la Pared**

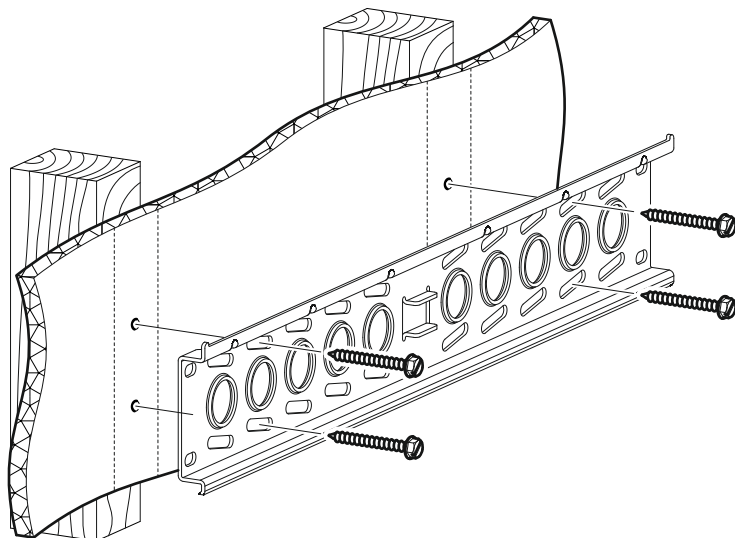

**Attach the TV**  
*Fixer la TV*  
**Coloque la TV**

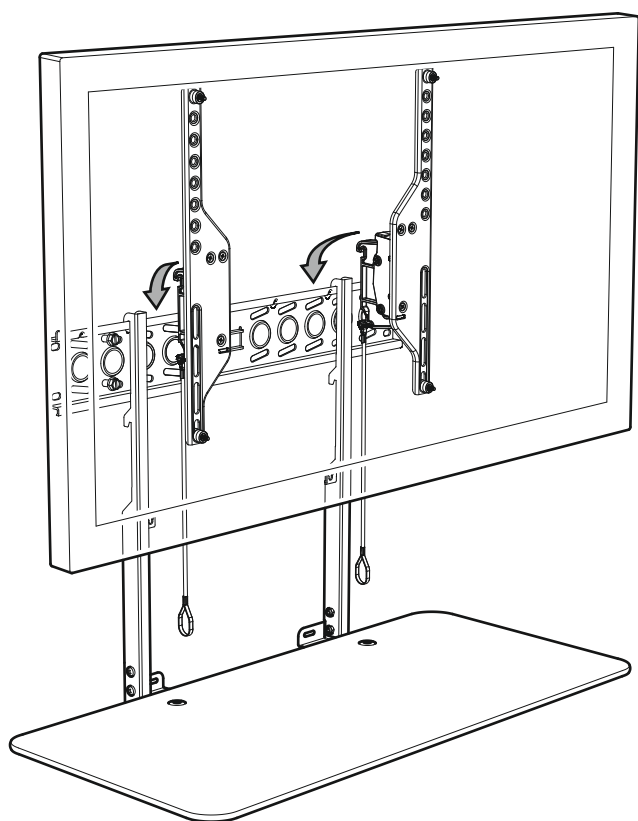

**Attach the Trim Panel**  
*Fixer le panneau de finition*  
**Coloque el Panel**

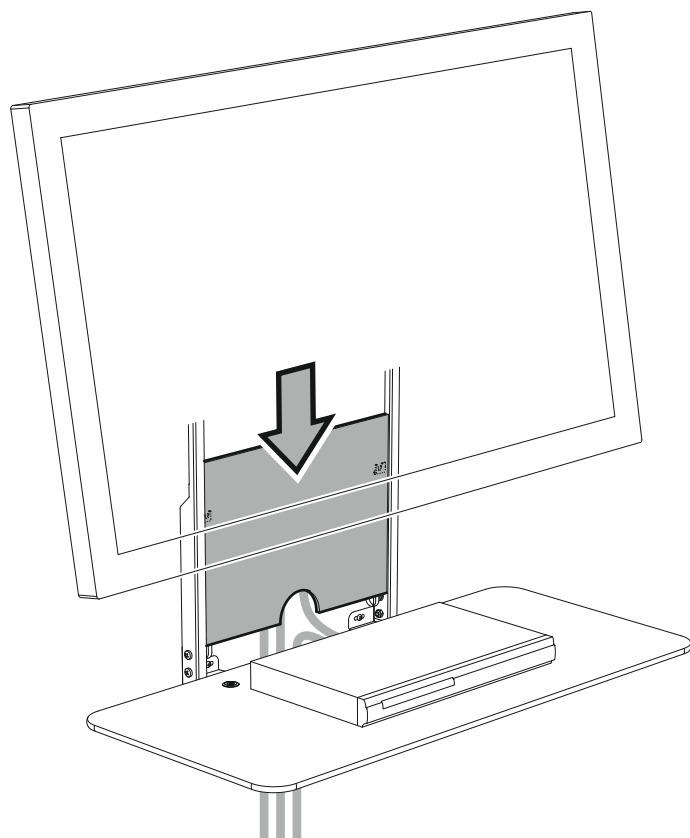

**Index**  
**Index**  
**Índice**

**1** Measure the TV fixing holes Width and Height  
*Mesurer la profondeur et la taille des trous de fixation*  
Mida los orificios de su TV, lo ancho y lo alto

**2** Assembling the Shelf Bracket  
*Assemblage du support à étagère*  
Ensamblando el Estante

**3** Select the Trim Panel  
*Sélectionner le panneau de finition*  
Seleccione el Color de Panel

**4** Considering the Shelf Position  
*Prendre en compte la hauteur de l'étagère*  
Considerando la Posición del Estante

**5** Fitting the TV Brackets  
*Installer l'applique téléviseur*  
Fije los Brazos del Soportes a su TV

**6** Fitting the Wall Bracket  
*Installer l'applique murale*  
Fije la Placa a la Pared

**7** Deciding the Shelf Position  
*Décider du positionnement de l'étagère*  
Decidiendo la Posición del Estante

**8** Remove the TV  
*Oter la TV*  
Remueva la TV

**9** Mark Holes for Drilling  
*Marquer les trous pour le perçage*  
Marque los Orificios de Perforación

**10** Remove the Shelf Bracket  
*Oter le support d'étagère*  
Remueva el Estante

**11** Preparing Holes for the Shelf Bracket  
*Préparer les trous pour le support étagère*  
Prepare los Orificios del Estante

**12** Attach the Shelf  
*Fixer l'étagère*  
Coloque el Estante

**13** Attach the TV  
*Fixer la TV*  
Coloque la TV

**14** Position DVD etc  
*Positionner DVD etc*  
Posicione su DVD, etc.

**15** Cable Management  
*Cache-câbles*  
Manejo de Cable

**16** Attach the Shelf Bracket to Wall  
*Fixer le support étagère au mur*  
Coloque el Estante a la Pared

**17** Attach the Trim Panel  
*Fixer le panneau de finition*  
Coloque el Panel

**18** Optional  
*Optionnel*  
Opcional

Retain all packaging in case the bracket needs to be returned.

Contents may vary from photography/ Illustrations.

You will not need all these parts, so expect there to be some left over depending upon the specification of your TV.

This product is intended for indoor use only. Use of this product outdoors could lead to failure and personal injury.

It is the responsibility of the installer to ensure that the mounting wall is of a suitable standard and void of any services (eg gas, electricity, water etc).

AVF accept no responsibility for any damage or loss caused by installing this product on a sub standard wall.

*Conserver les emballages si l'applique a besoin d'être ramenée.*

*Les contenus peuvent varier de la photographie/illustrations.*

*Vous n'aurez pas besoin de toutes ces pièces, attendez-vous donc à ce qu'il reste des pièces selon les caractéristiques de votre téléviseur..*

*Ce produit est à utiliser à l'intérieur uniquement. Utiliser ce produit à l'extérieur causera des défaillances et de possibles accidents..*

*Il est de la responsabilité de l'installateur de s'assurer que les murs soient aux critères requis et vides de tout câblage (ex : gaz, électricité, eau etc...)*

*AVF n'acceptera aucune responsabilité pour tout dommage ou perte causée par l'installation du produit dans un mur en deçà de ces critères.*

*Conserve todos los envasados en caso de que el soporte tenga que ser devuelto.*

*El contenido puede variar de la fotografía / ilustración.*

*No necesitará todas estas partes, espere que sobren algunas según las especificaciones de su TV.*

*Este producto está diseñado para el uso en el interior solamente. El uso de este producto en el exterior podría llevar al fracaso y lesiones personales.*

*Es la responsabilidad del instalador de asegurarse de que la pared de montaje es de un nivel adecuado y carece de todo los servicios (gas, electricidad, agua, etc.).*

*AVF no acepta ninguna responsabilidad por cualquier daño o pérdida causada por la instalación de este producto en una pared inadecuada.*

**Tools Recommended**  
**Outils recommandés**  
**Herramientas recomendadas**

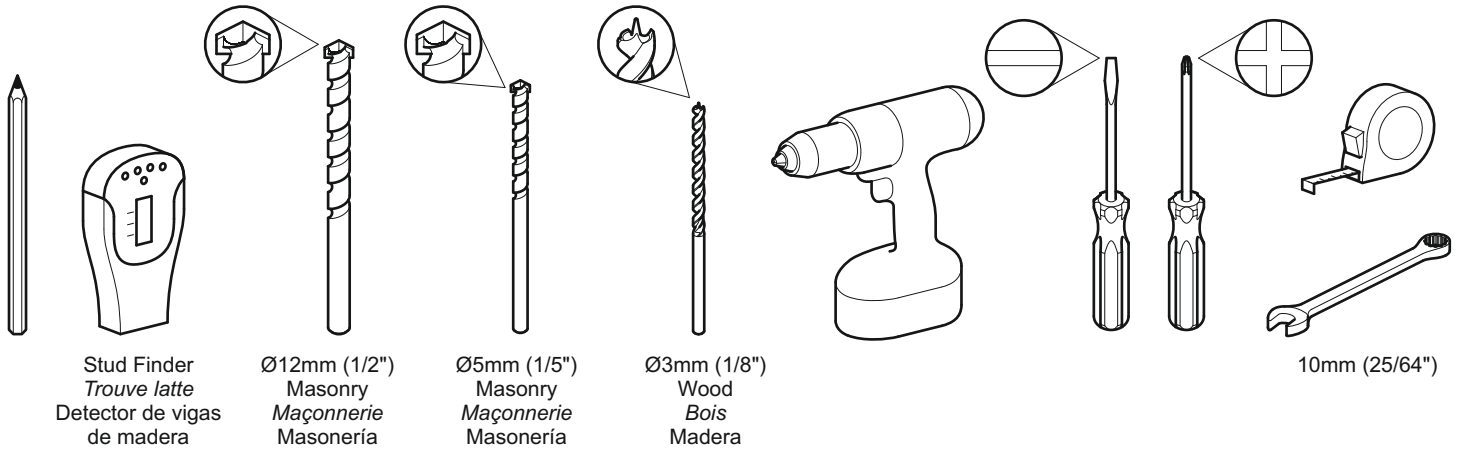

**Boxed Parts**  
**Pièces empaquetées**  
**Piezas en la Caja**

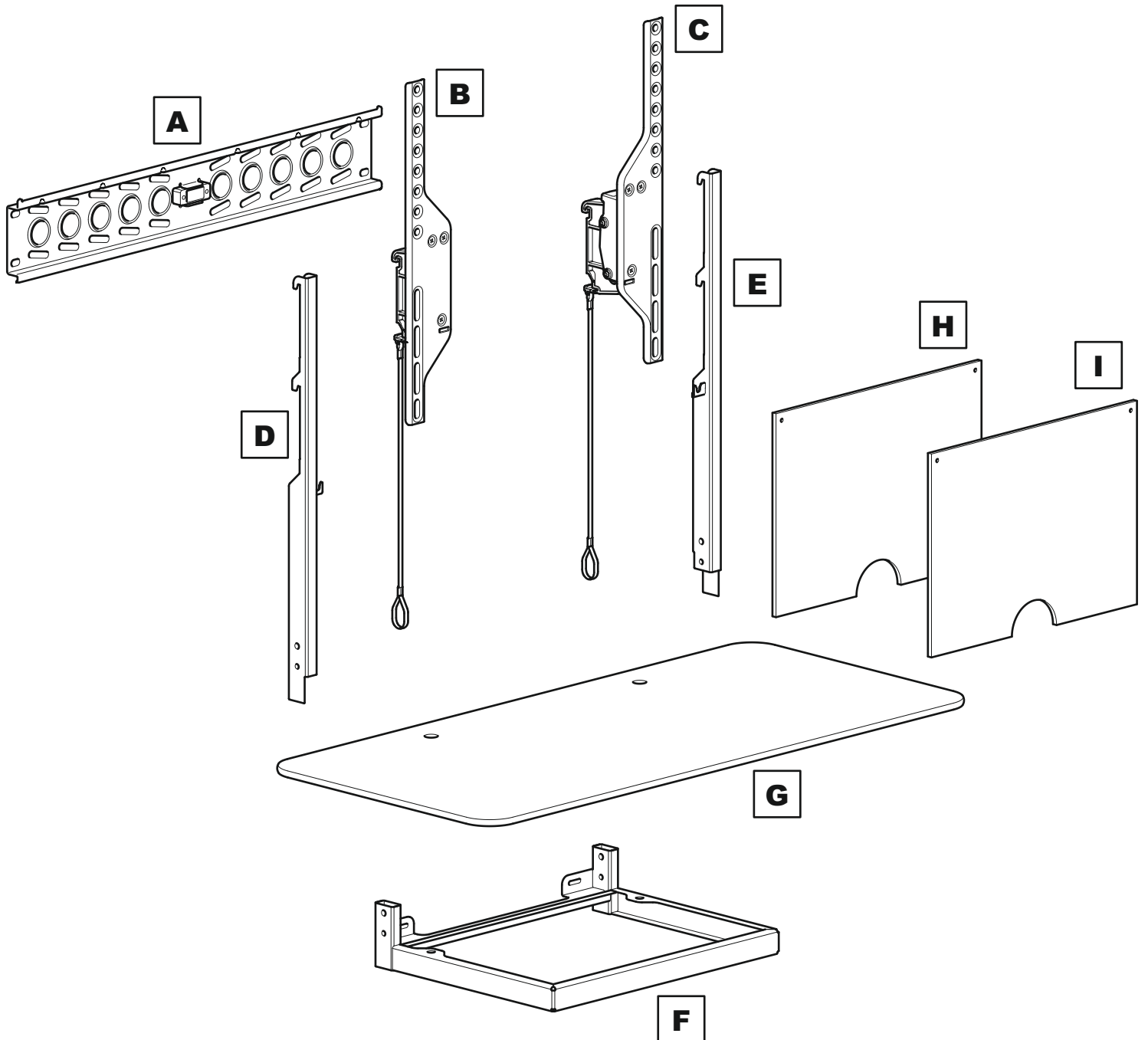

TV Screws, Reducers and Spacers  
 Vis TV, réducteurs et séparateurs  
 Tornillos, Reductores y Espaciadores para TV

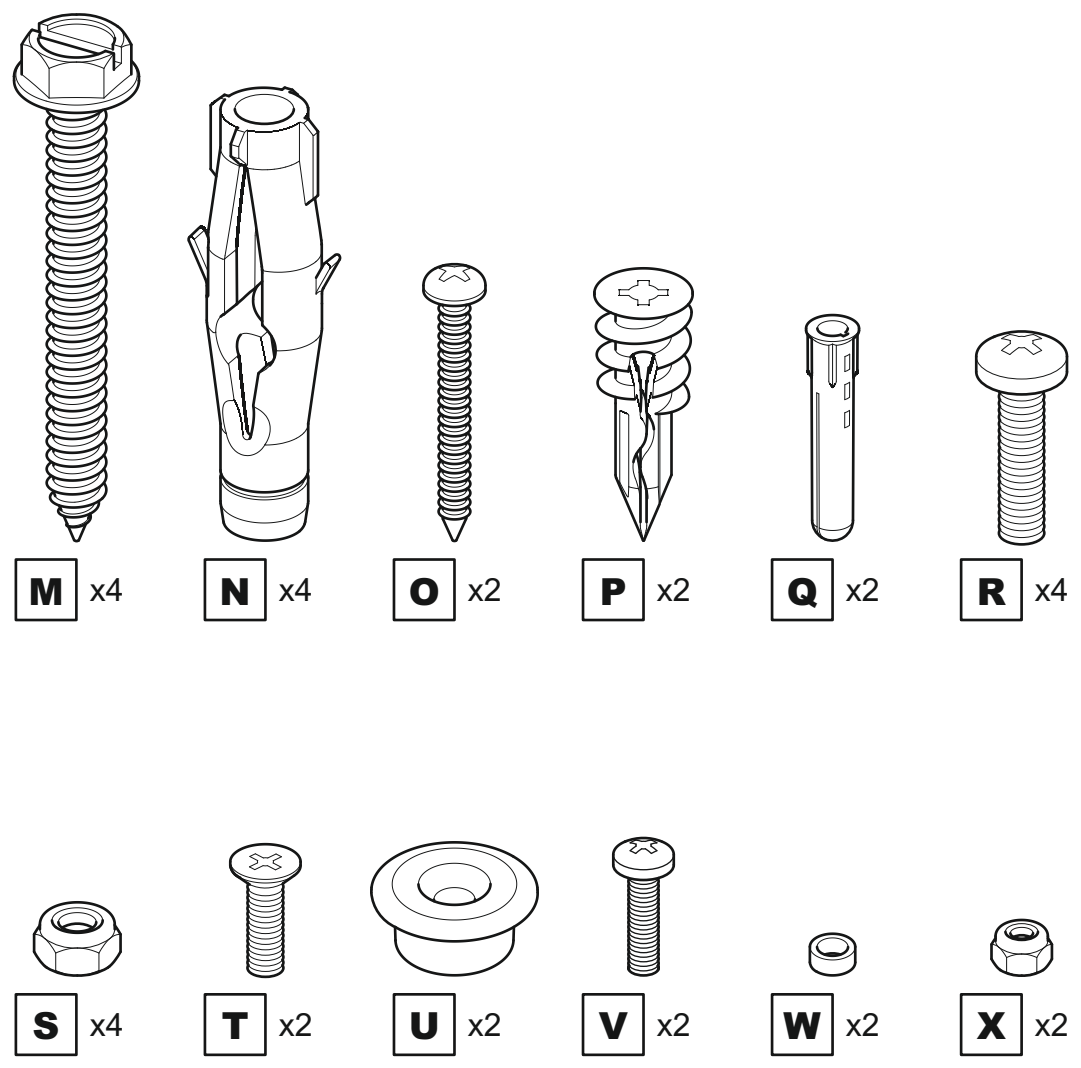
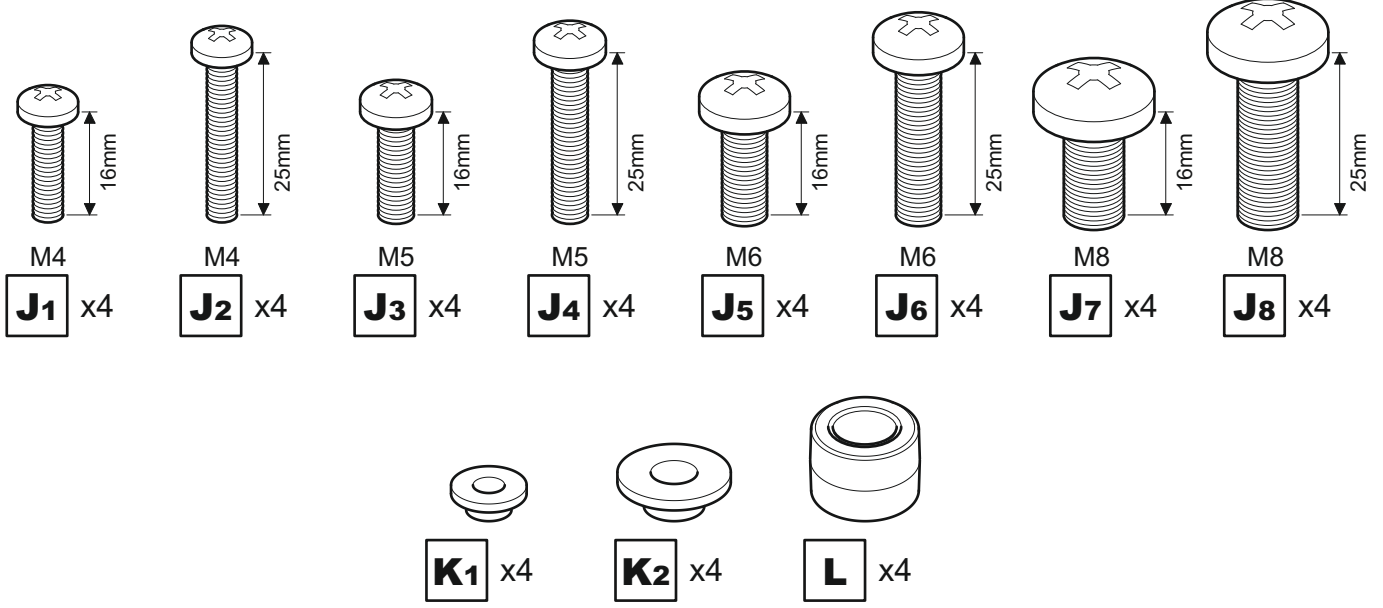

**1** Measure the TV Fixing Holes Width and Height  
*Mesurer la profondeur et la taille des trous de fixation*  
 Mida los orificios de su TV, lo ancho y lo alto

TV Fixing Holes  
*Trous de fixation TV*  
 Orificios de su TV  
 para Fijar el Soporte

If width (X) is greater than 660mm or height (Y) greater than 400mm STOP installation now and contact the customer help line

*Si la largeur (X) est plus large que 660mm et la hauteur (Y) plus grande que 400mm, ARRÊTEZ l'installation immédiatement et contactez l'assistance client*

Si la anchura (X) es mayor que 660mm o la altura de (Y) es mayor que 400mm DETENGA la instalación inmediatamente y póngase en contacto con la línea de ayuda al cliente

(X) 75 - 660mm

(Y) 75 - 400mm

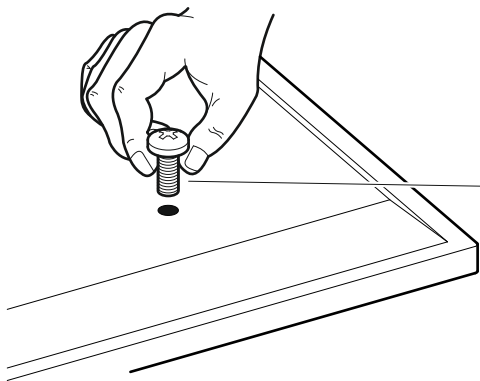
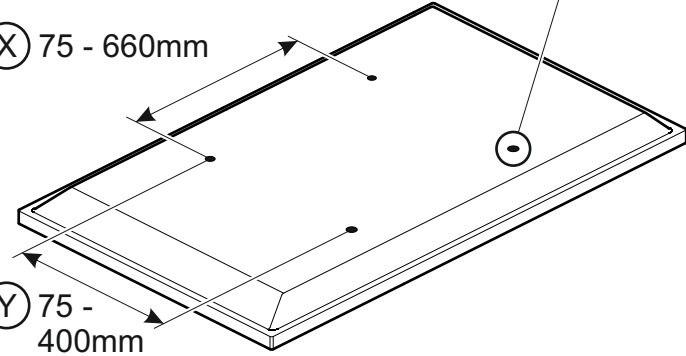

M4 = J1/J2

M5 = J3/J4

M6 = J5/J6

M8 = J7/J8

You are provided with 4 diameters of TV fixing screws, **M4, M5, M6** and **M8**. Determine the screw diameter that fits and remember for step 5.

*4 diamètres de vis TV vous sont fournis, M4, M5, M6, et M8. Déterminez le diamètre de la vis qui convient et mémorisez- le pour l'étape 5.*

Se le proporciona con 4 diámetros de tornillos de fijación para su TV: M4, M5, M6 y M8. Determine el diámetro del tornillo que le quede a su TV y recuérdelo para el paso 5.

**2** Assembling the Shelf Bracket  
*Assemblage du support à étagère*  
 Ensamblando el Estante

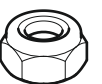
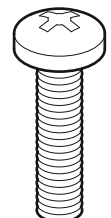
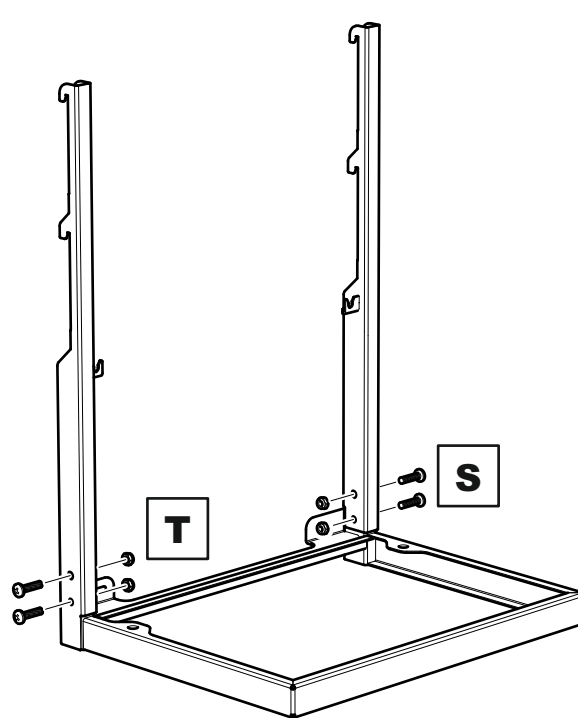
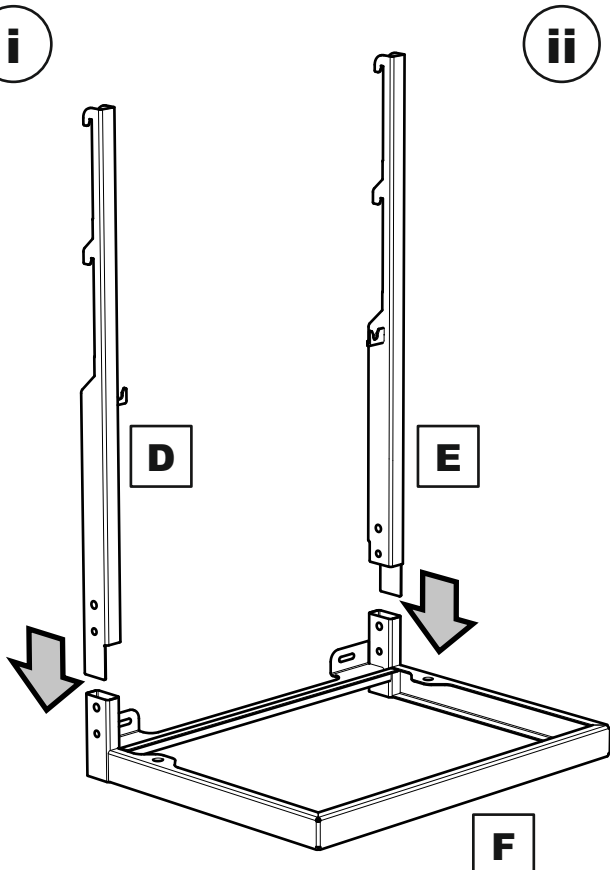

**S** x4

**T** x4

**3**

Select the Trim Panel  
*Sélectionner le panneau de finition*  
 Seleccione el Color de Panel



DO NOT OVER TIGHTEN/ *NE PAS VISSER A FOND/* NO SOBRE APRIETE

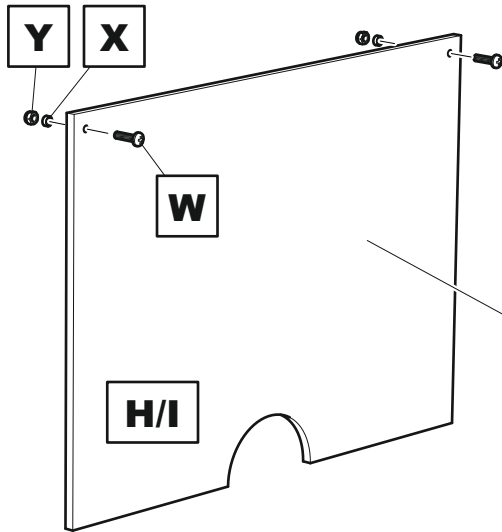

Selected trim this side  
*La finition choisie se place de ce côté.*  
 Coloque el panel de su color elegido en este lado.

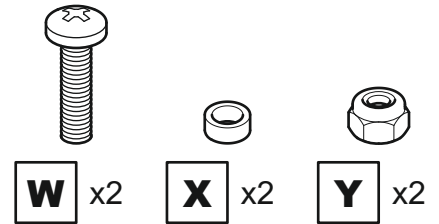
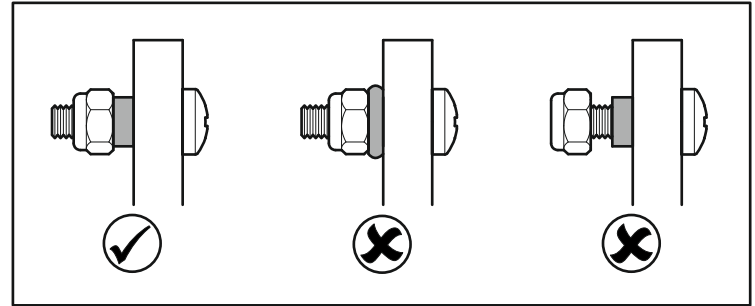
**4**

Considering the Shelf Position  
*Prendre en compte la hauteur de l'étagère*  
 Considerando la Posición del Estante

Before fitting the wall bracket consider the shelf position. If you position the wall bracket too low, the shelf could be too close to the floor, if you position the wall bracket too high, the TV could be too close to the ceiling and/or shelving be too high. Use the dimensions below as a guide.

Avant de mettre en place le support mural, prendre en compte le positionnement de l'étagère. Si vous positionnez le support mural trop bas l'étagère pourrait se trouver trop près du sol, si vous positionnez le support trop haut la TV pourrait se trouver trop près du plafond et/ou l'étagère trop haute. Utiliser les dimensions précisées ci-dessous comme guide.

Antes de fijar el soporte de pared tome en cuenta la posición del estante. Si usted posiciona el soporte de pared muy abajo, el estante podría estar muy cerca del piso. Si la posición del soporte de pared está muy alta, la TV puede estar muy cerca del techo y/o el estante puede estar demasiado alto. Utilice las dimensiones a continuación como guía. ceiling and/or shelving be too high. Use the dimensions below as a guide.

**High Shelf Position**  
*Etagère en position haute*  
 Posición Alta del Estante

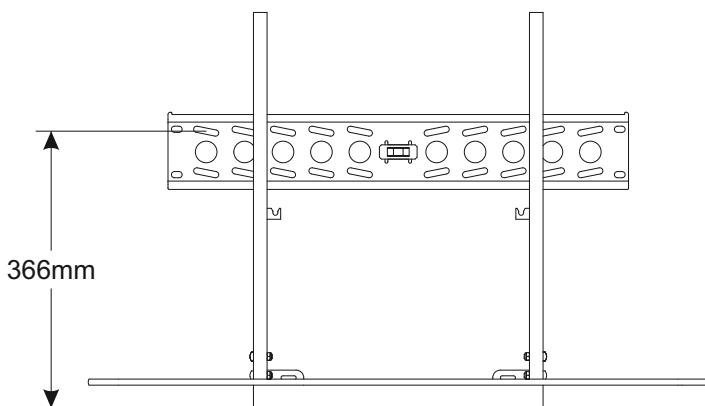

Recommended for Medium to Large TV  
*Recommandé pour des TVs de moyenne et grande tailles*  
 Recomendada para TVs Medianas – Grandes

**Low Shelf Position**  
*Etagère en position basse*  
 Posición Baja del Estante

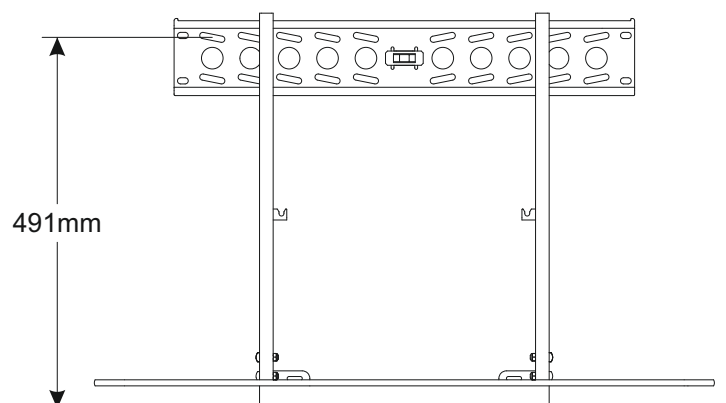

Recommended for Large to Extra Large TV  
*Recommandé pour des TVs de grande et très grande taille*  
 Recomendada para TVs Grandes – Extra Grandes

# 5

## Fitting the TV Brackets *Installer l'applique téléviseur* Fije los Brazos del Soportes a su TV

**No Spacers**  
**Pas de Séparateur**  
**Sin espaciadores**

For TVs with flat/unobstructed back  
*Pour des téléviseurs aux dos plats et non obstrués*  
 Para TVs con la parte posterior plana/sin obstáculos

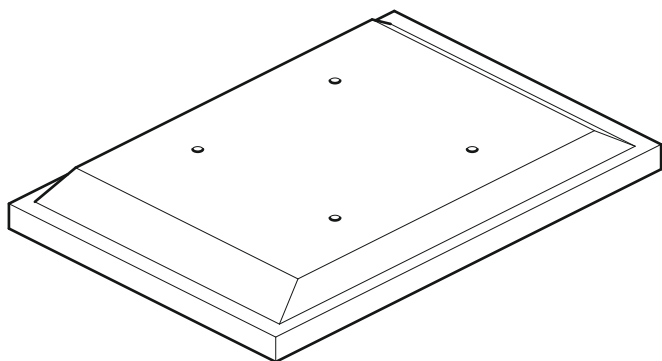

**Spacers**  
**Séparateur**  
**Espaciadores**



For TVs with irregular/obstructed back  
*Pour des téléviseurs aux dos irréguliers et non obstrués*  
 Para TVs con la parte posterior irregular/con obstáculos

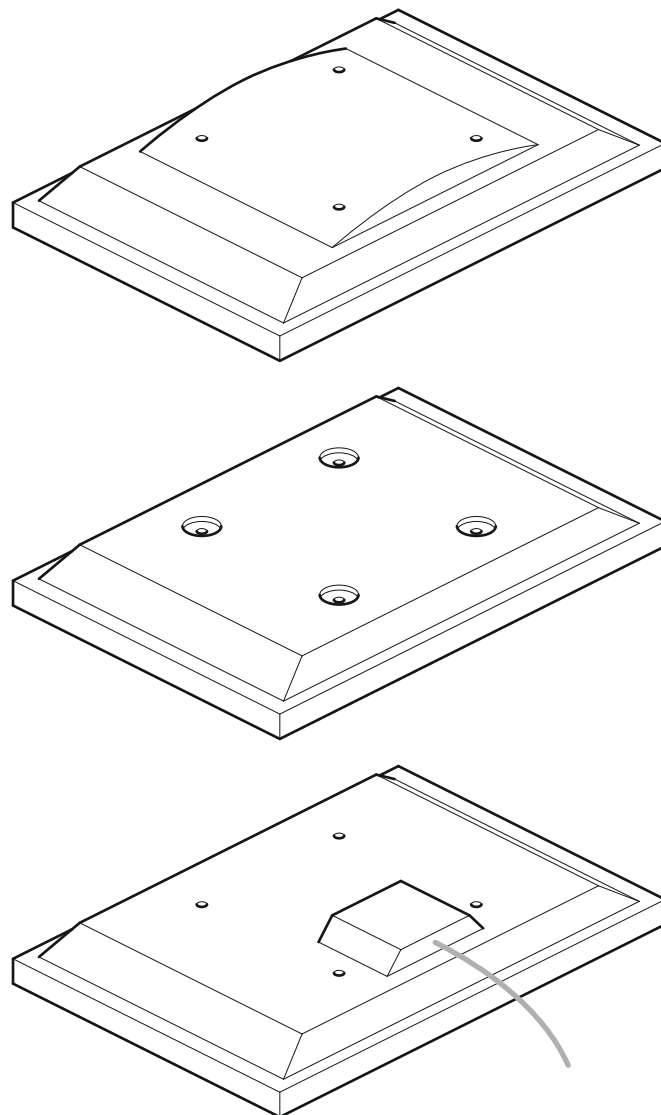

### WARNING / AVERTISSEMENT / ADVERTENCIA

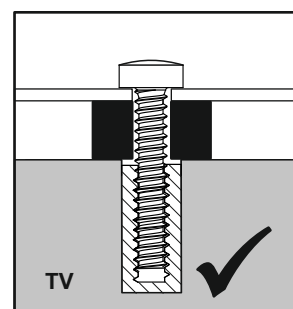
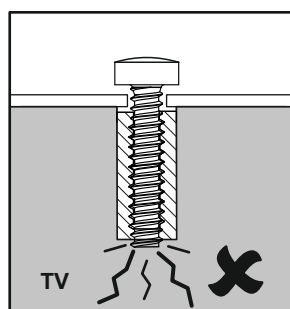
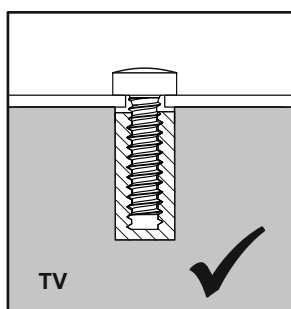
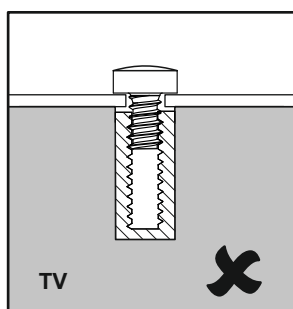

After completing step 5 you will have fittings left over, please keep for future reference  
*Après avoir complété l'étape 5 il vous restera des pièces d'assemblage, conservez-les*  
 Después de completar el paso 5 usted tendrá conexiones sobrantes, por favor guarde para futura referencia.





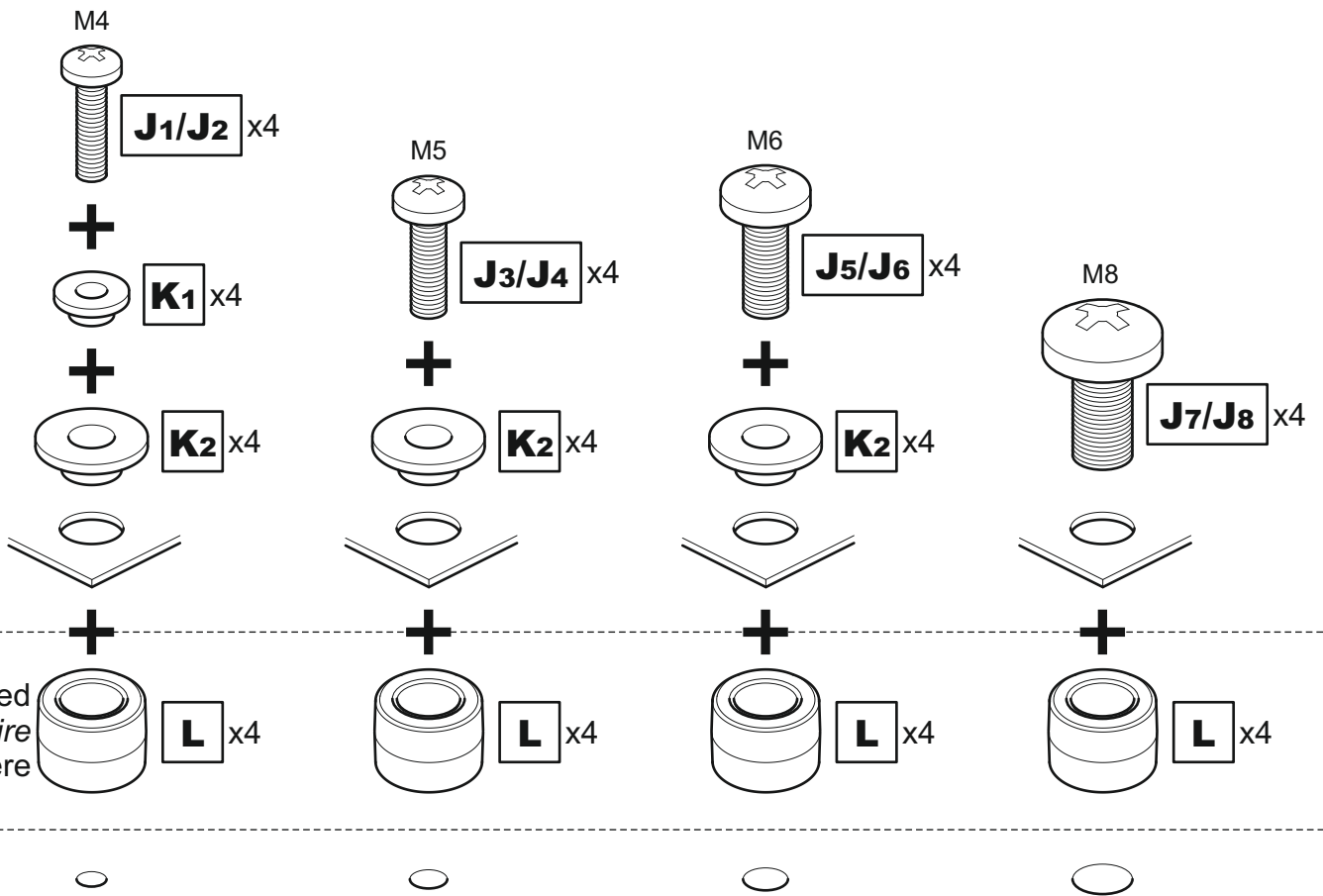
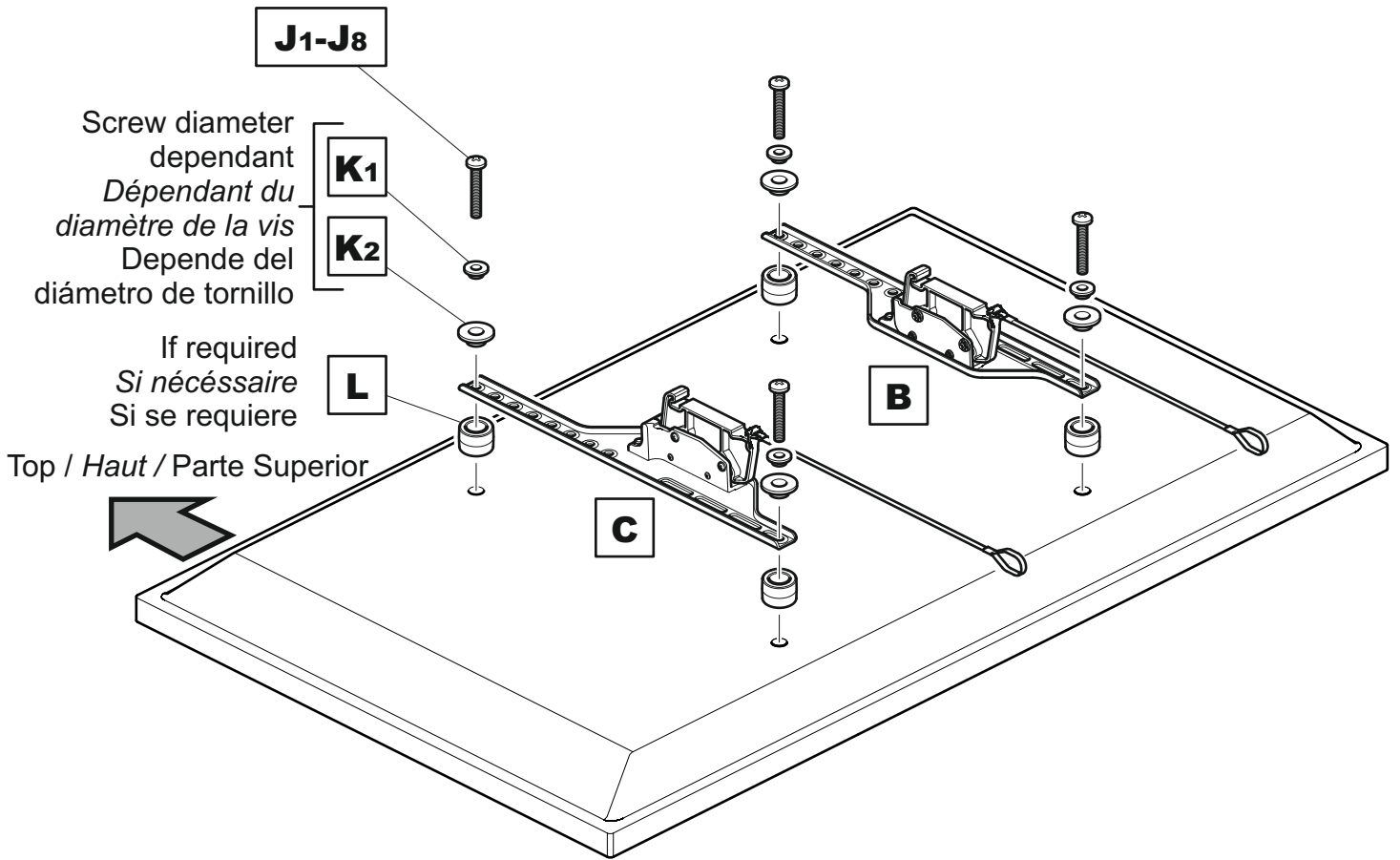

Attach the brackets to the back of your TV using suitable screw, reducer and spacer combinations  
*Attachez l'applique au dos de votre téléviseur en utilisant une combinaison de vis, de séparateurs et de joints adaptés*  
 Coloque los soportes a la parte posterior de su TV usando la combinación adecuada de tornillo, reductor y espaciador.

# 6

## Fitting the Wall Bracket *Installer l'applique murale* Fije la Placa a la Pared



Remember to use the measurements from step 4  
*Se rappeler d'utiliser les mesures de l'étape 4*  
 Recuerde que debe utilizar las medidas del paso 4

**Solid Wall / Mur solide / Pared sólida**



Remove dust from hole  
*Retirez la poussière du trou*  
 Elimine el polvo del agujero

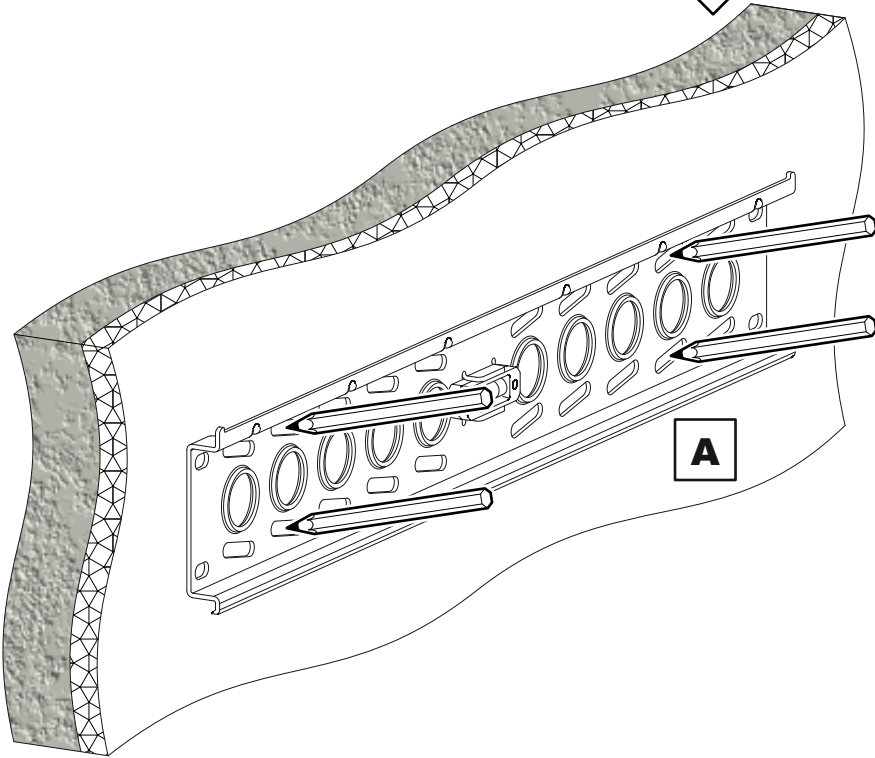
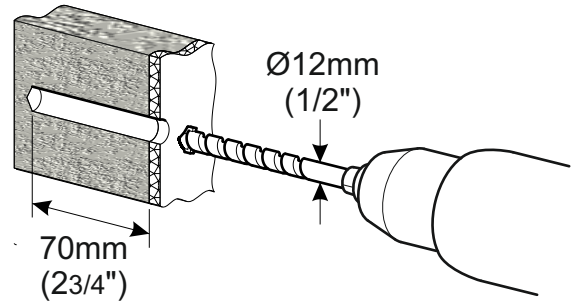

**A**



Lubricate screw thread with soap  
*Lubrifiez le pas de vis avec du savon*  
 Lubrique la rosca del tornillo con jabón

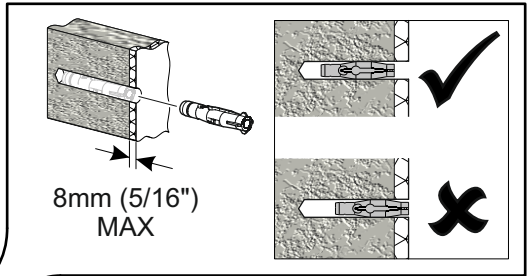

8mm (5/16")  
 MAX

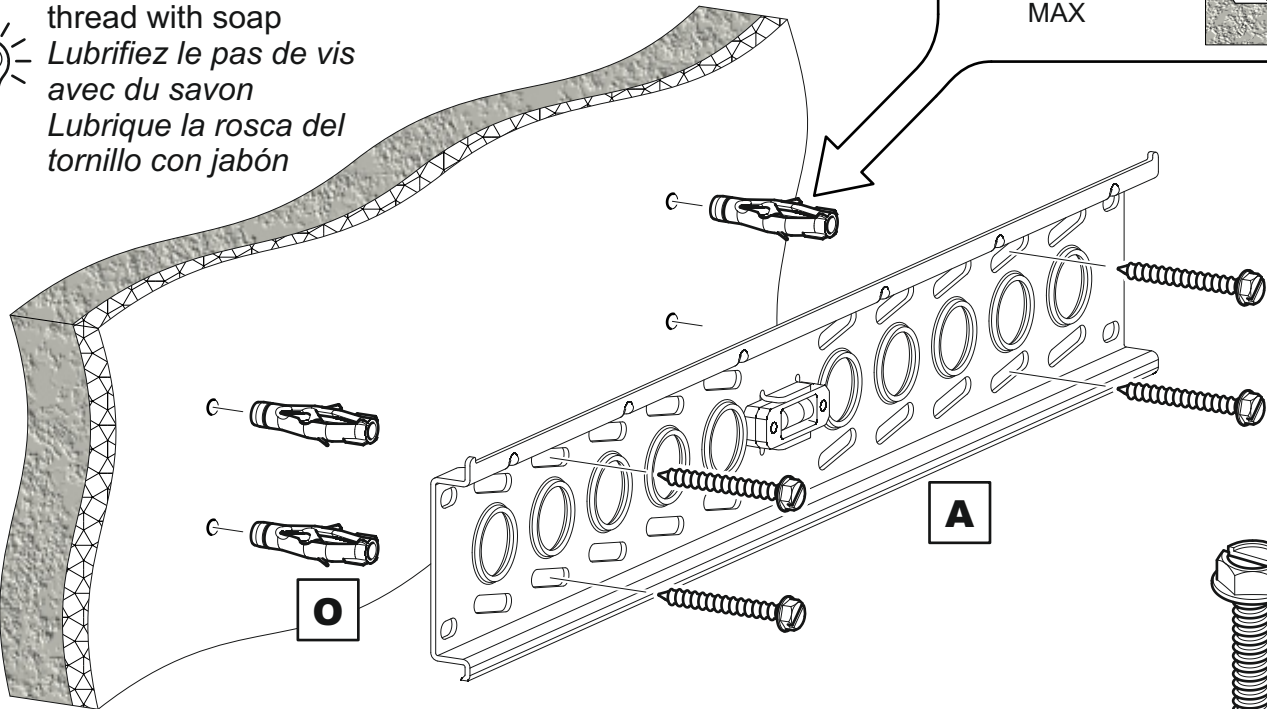

**O**

**A**

**N**

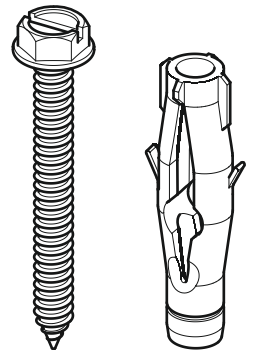

**N** x4

**O** x4



Ensure level before final tightening. **DO NOT** over tighten screws.  
 Tighten screws by hand only  
*S'assurer du bon nivellement avant le serrage final. NE PAS visser les vis à fond. Visser à la main*  
 Asegúrese que este nivelado antes de darle el apriete final. **NO** sobre apriete los tornillos. Apriete los tornillos sólo a mano.

Wood Stud / latte de bois / Viga de madera

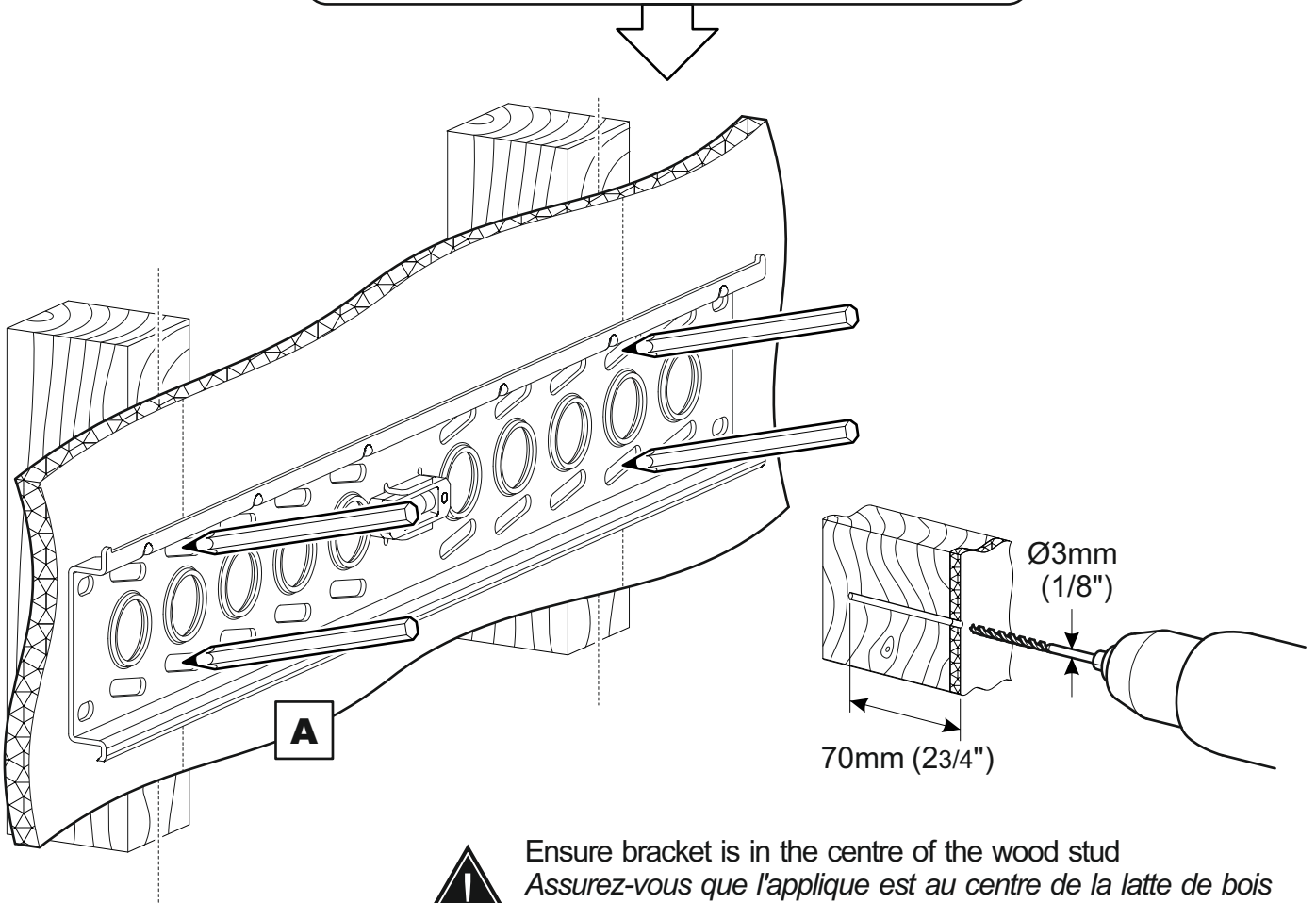

Ensure bracket is in the centre of the wood stud  
*Assurez-vous que l'applique est au centre de la latte de bois*  
*Asegúrese de que el soporte está en el centro de la viga de madera*



Lubricate screw thread with soap  
*Lubrifiez le pas de vis avec du savon*  
*Lubrique la rosca del tornillo con jabón*

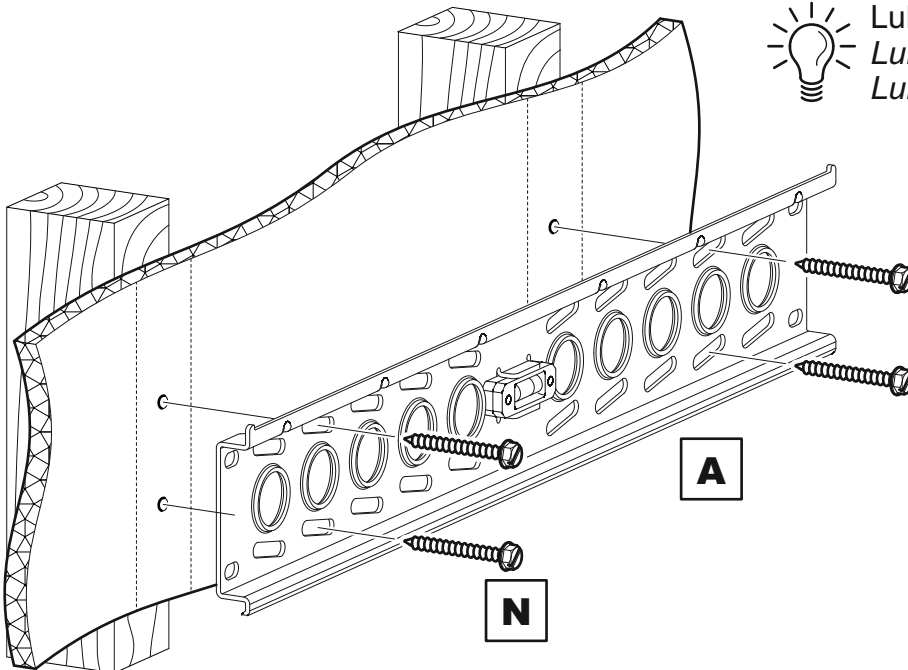

Ensure level before final tightening. DO NOT over tighten screws.  
Tighten screws by hand only  
*S'assurer du bon nivellement avant le serrage final. NE PAS visser les vis à fond. Visser à la main*  
*Asegúrese que este nivelado antes de darle el apriete final. NO sobre apriete los tornillos. Apriete los tornillos sólo a mano*

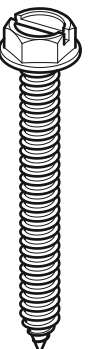

**N** x4

# 7

## Deciding the Shelf position Décider du positionnement de l'étagère Decidiendo la Posición del Estante

1. Hang Shelf Bracket  
 1. Fixer le support d'étagère  
 1. Cuelgue el Estante

2. Attach TV  
 2. Fixer la TV  
 2. Coloque la TV

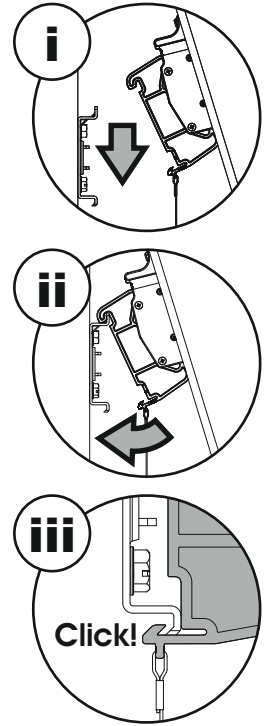
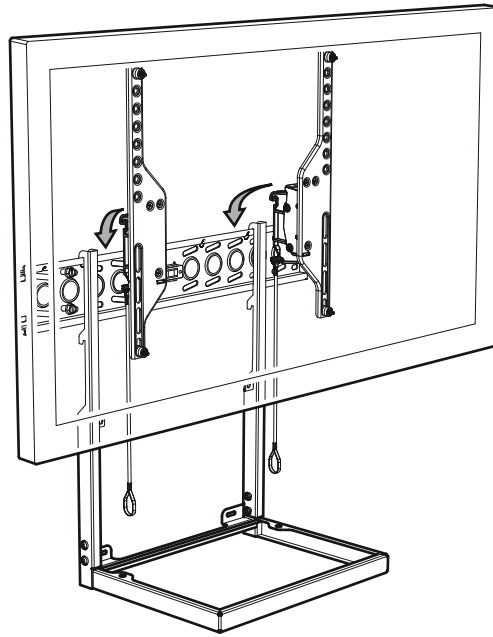
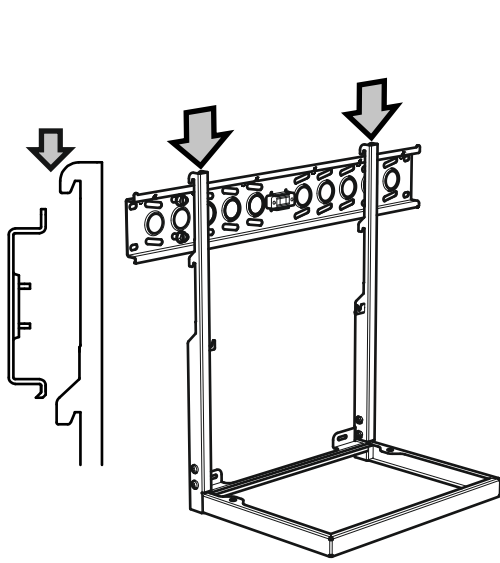

After you have attached your TV use the visuals below to determine if you need to position your shelf in the **High Shelf Position** or **Low Shelf Position**.

*Une fois la TV fixée, utilisez les visuels ci-dessous pour déterminer si vous devez positionner votre étagère en **position haute** ou en **position basse***

Después de haber conectado su TV utilice las imágenes a continuación para determinar si es necesario colocar el estante en la **Posición Alta del Estante** o **Posición Baja del Estante**

**High Shelf Position**  
**Etagère en position haute**  
**Posición Alta del Estante**

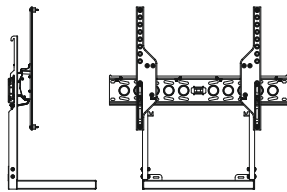

**Low Shelf Position**  
**Etagère en position basse**  
**Posición Baja del Estante**

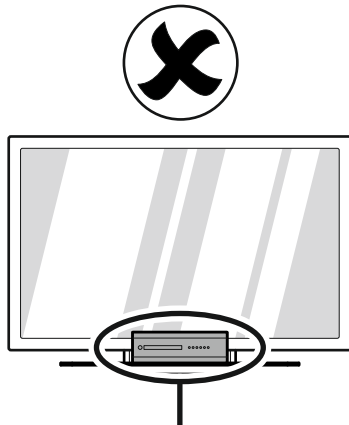
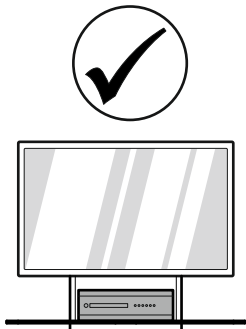
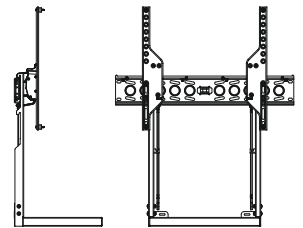

DVD etc clashes with TV  
 DVD etc sont en conflit avec la TV  
 DVD, etc. choca con TV

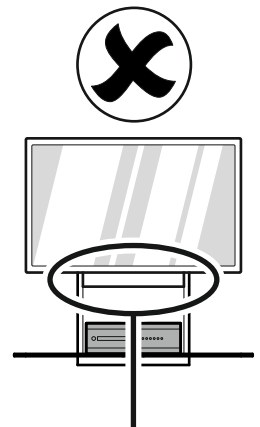
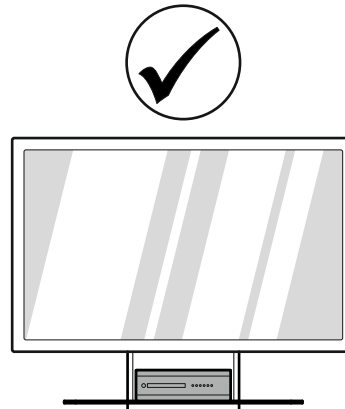

Visible gap between TV and Trim Panel  
 Visible gap between TV and Trim Panel  
 Espacio visible entre la TV y el panel de color elegido

**8**

Remove the TV  
*Oter la TV*  
Remueva la TV

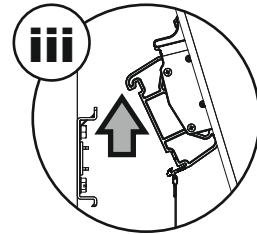
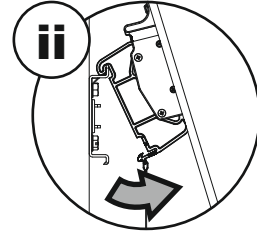
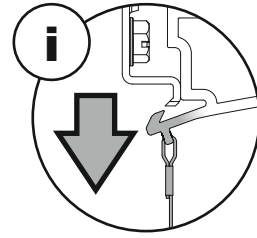
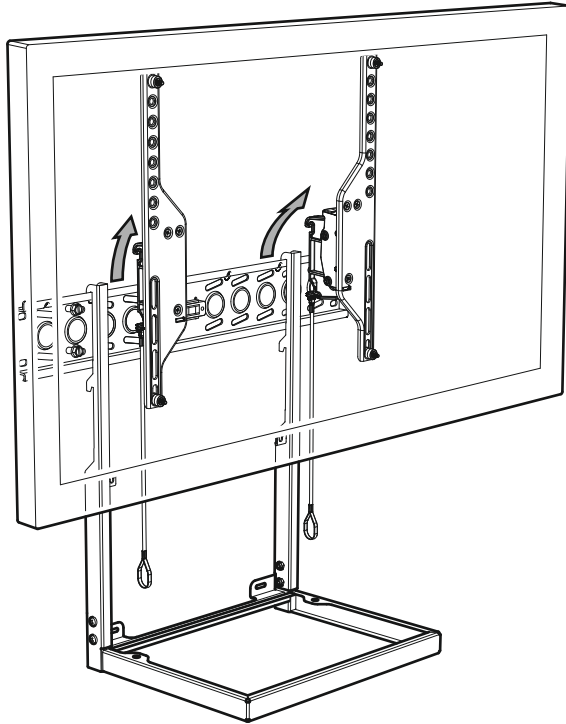
**9**

Mark Holes for Drilling  
*Marquer les trous pour le perçage*  
Marque los Orificios de Perforación

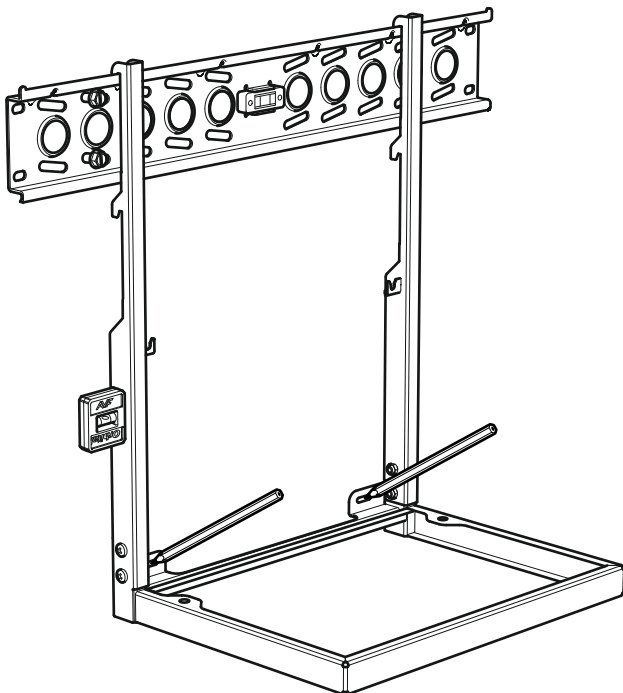
**10**

Remove the Shelf Bracket  
*Oter le support d'étagère*  
Remueva el Estante

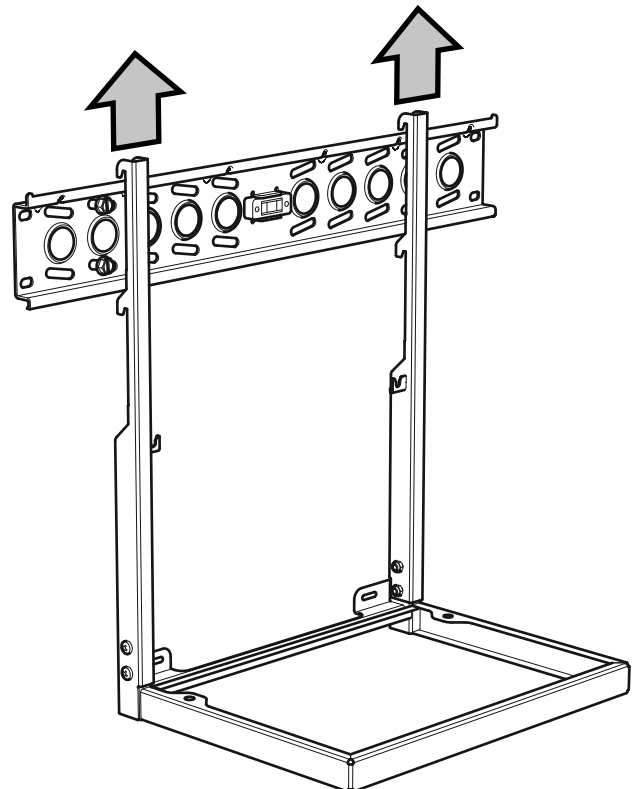

# 11

## Preparing Holes for the Shelf Bracket Préparer les trous pour le support étagère Prepare los Orificios del Estante

Solid Wall / Mur solide / Pared sólida

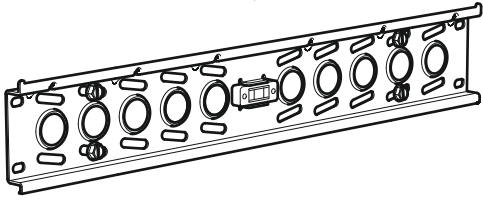

Remove dust from hole  
Retirez la poussière du trou  
Elimine el polvo del agujero

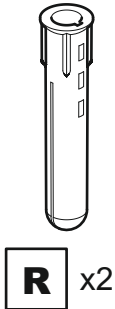
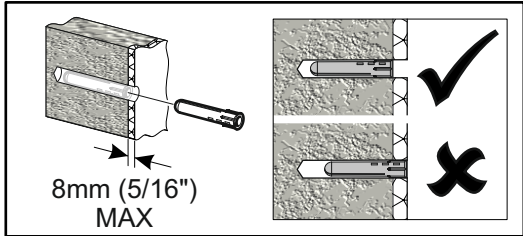
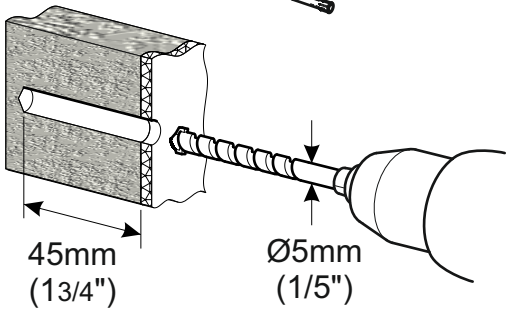

Plasterboard/ Placo-plâtre/ Cartón-Yeso (Pladur)

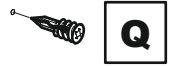
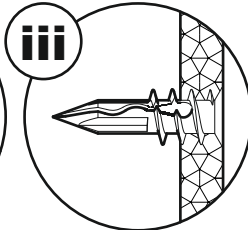
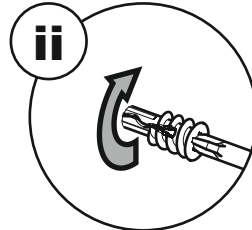
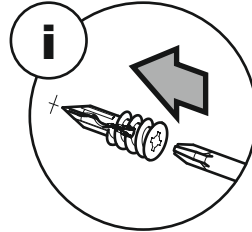
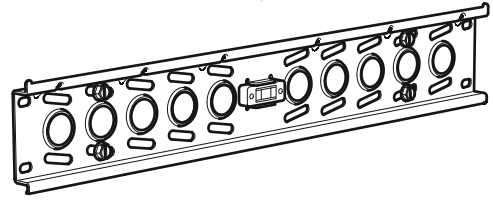

# 12

## Attach the Shelf Fixer l'étagère Coloque el Estante

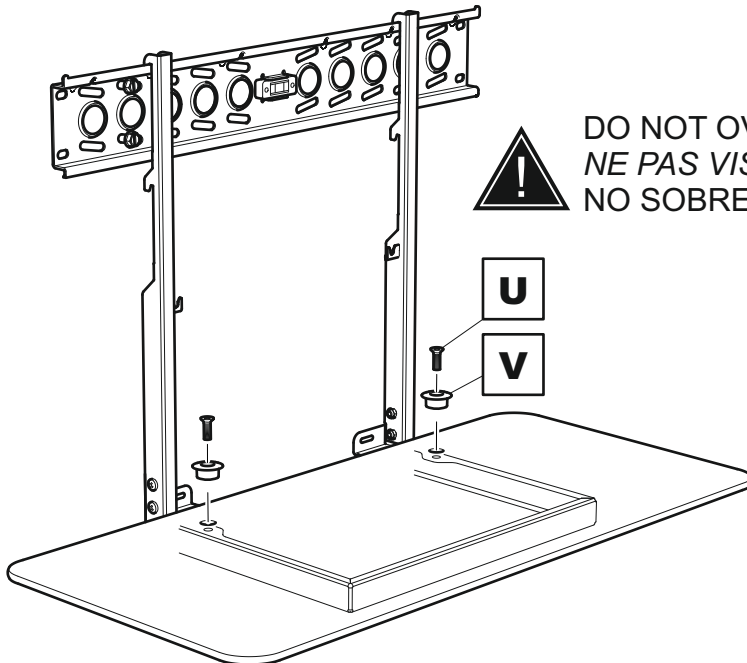

DO NOT OVER TIGHTEN  
NE PAS VISSER A FOND  
NO SOBRE APRIETE LOS TORNILLOS

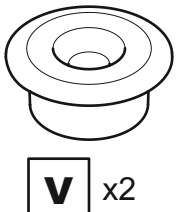
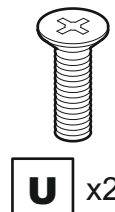

**13**

**Attach the TV**  
*Fixer la TV*  
**Coloque la TV**

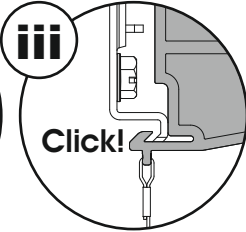
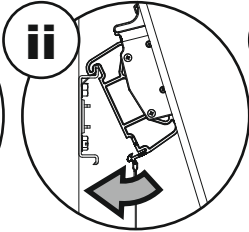
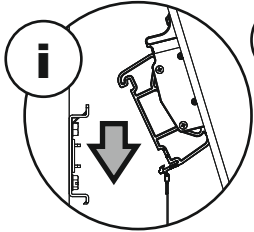
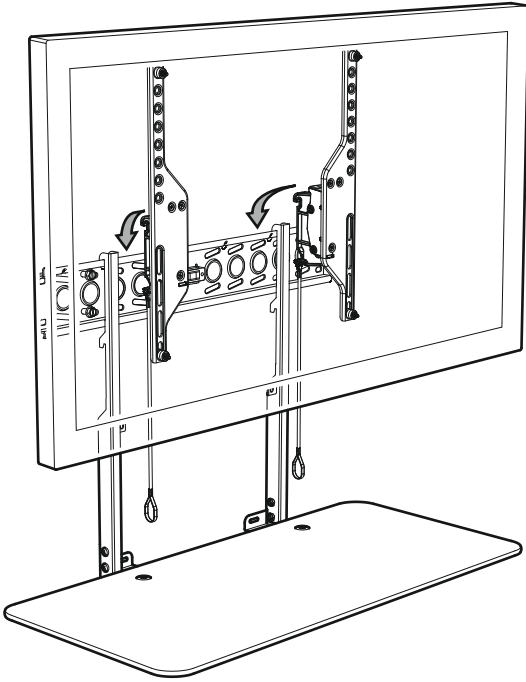
**14**

**Position DVD etc**  
*Positionner DVD etc*  
**Posicione su DVD, etc.**

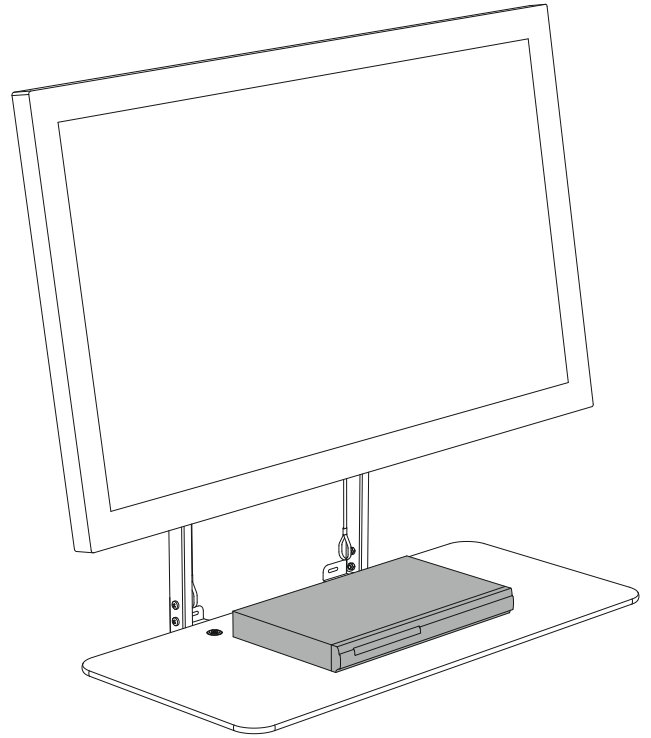

Shelf capacity 15kg (33lbs)  
*L'étagère supporte 15kg (33lbs)*  
 Capacidad del estante 15kg (33lbs)

**15**

**Cable Management**  
*Cache-câbles*  
**Manejo de Cable**

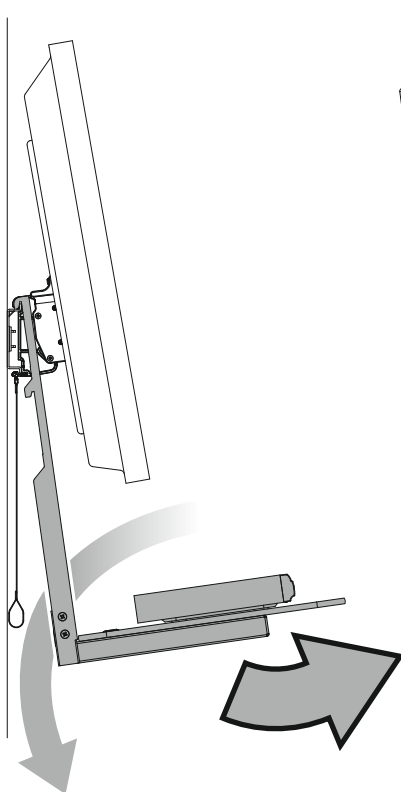

Power Cables,  
 HDMI Cables,  
 Scart Cables,  
 Aerial Cables etc  
*Câbles d'alimentation,*  
*câbles HDMI,*  
*cables péritel,*  
*cables antenne etc*  
 Cables eléctricos,  
 Cables HDMI, Cables  
 Scart, Cables de  
 Antena, etc.

16

Attach the Shelf Bracket to Wall  
*Fixer le support étagère au mur*  
Coloque el Estante a la Pared

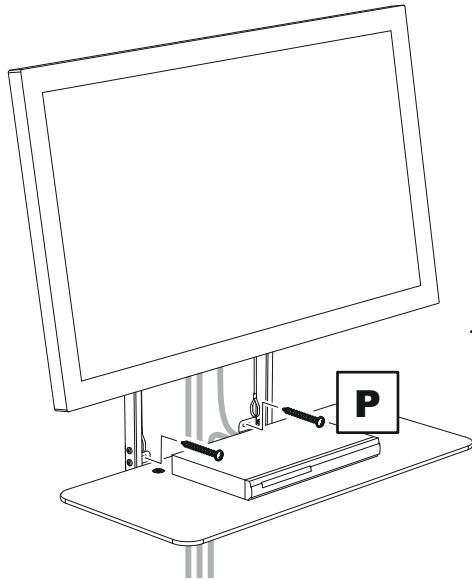

Lubricate screw thread with soap  
*Lubrifiez le pas de vis avec du savon*  
*Lubrique la rosca del tornillo con jabón*



**P** x2

17

Attach the Trim Panel  
*Fixer le panneau de finition*  
Coloque el Panel

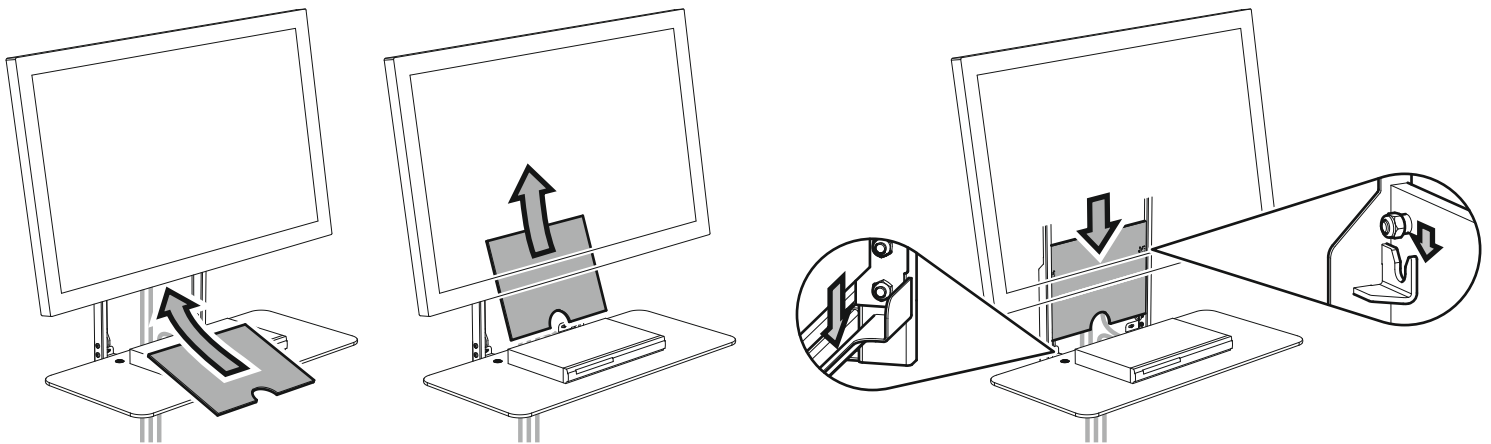

18

Optional  
*Optionnel*  
Opcional

Tilt  
*Inclinaison*  
Inclinación

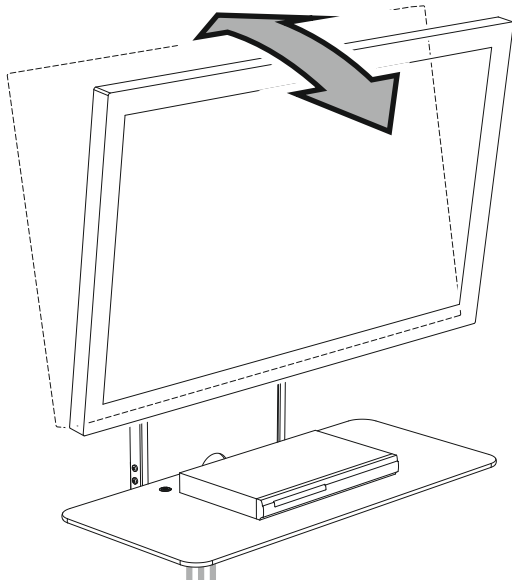

Lock  
*Vérouillée*  
Cerradura

